

# Flexible Disc Couplings

## TB Wood's Form-Flex® & Torsiflex-i



Ameridrives • Bibby Turboflex • Guardian Couplings  
Huco • Lamiflex Couplings • TB Wood's

# TB Wood's

TB Wood's is an industry leading designer and manufacturer of mechanical power transmission equipment for industrial control. Our mechanical product lines include: clutch and brake, synchronous and belted variable speed drives; grid, disc, jaw, gear coupling and elastomeric coupling products; sheaves and bushings. Registered trademarks include Sure-Flex Plus®, Dura-Flex®, G-Flex®, and Sure-Grip®.

TB Wood's was founded in 1857 and began as a foundry producing wood burning stoves. Our company's tradition of product innovation started early. TB Wood's entered the power transmission industry at the turn of the century with the introduction of flat belted drives and line shafting.

VISIT US ON THE WEB AT  
**TBWOODS.COM**



# Altra Motion

Altra is a leading global designer and producer of a wide range of electromechanical power transmission and motion control components and systems. Providing the essential control of equipment speed, torque, positioning, and other functions, Altra products can be used in nearly any machine, process or application involving motion. From engine braking systems for heavy duty trucks to precision motors embedded in medical robots to brakes used on offshore wind turbines, Altra has been serving customers around the world for decades.

Altra's leading brands include **Ameridrives**, **Bauer** Gear Motor, **Bibby** Turboflex, **Boston** Gear, **Delevan**, **Delroyd** Worm Gear, **Formsprag** Clutch, **Guardian** Couplings, **Huco**, **Jacobs** Vehicle Systems, **Kilian**, **Kollmorgen**, **Lamiflex** Couplings, **Marland** Clutch, **Matrix**, **Nuttall** Gear, **Portescap**, **Stieber**, **Stromag**, **Svendborg** Brakes, **TB Wood's**, **Thomson**, **Twiflex**, **Warner** Electric and **Wichita** Clutch.

VISIT US ON THE WEB AT **ALTRAMOTION.COM**



# Form-Flex<sup>®</sup> & Torsiflex-i Flexible Disc Couplings

**F5**



# Table of Contents

---

## Introduction

Product Features and Options .....	Page F5-3
Disc Coupling Advantages .....	Page F5-3
Typical Applications .....	Page F5-3
Coupling Application Types .....	Page F5-4
Coupling Selection Process .....	Page F5-5
Coupling Selection Guide .....	Page F5-6
Standard Bore Tolerances .....	Page F5-7
Industry Standard Reference .....	Page F5-8
Dynamic Balance Recommendations .....	Page F5-8
Disc Coupling Misalignment Discussion .....	Page F5-8
Product Differentiation .....	Page F5-9

### Spacer Couplings

AP Series - Form-Flex® .....	Page F5-11
GP Series - Form-Flex® .....	Page F5-12, F5-13
TFI Series- Torsiflex-i - API610 .....	Page F5-14, F5-15
TFI Series - Torsiflex-i - API610 with Torsi-Lock.....	Page F5-16, F5-17

### Floating Shaft Couplings

A5 Series - Form-Flex® .....	Page F5-19
G5 Series - Form-Flex® .....	Page F5-20, F5-21
A5C Series (Composite) - Form-Flex® .....	Page F5-22, F5-23

### Closed Coupled Couplings

AX Series - Form-Flex® .....	Page F5-25
AA Series - Form-Flex® .....	Page F5-26
AY Series - Form-Flex® .....	Page F5-27

### Single Flex Couplings

AR Series - Form-Flex® .....	Page F5-29
GR Series - Form-Flex® .....	Page F5-30, F5-31

### Heavy Duty Spacer Couplings

GCH Series - Form-Flex® .....	Page F5-33
GCF Series - Form-Flex® .....	Page F5-34
HSH Series - Form-Flex® .....	Page F5-35
FSH Series - Form-Flex® .....	Page F5-36
Coupling Repair Parts and Kits .....	Page F5-38, F5-39
Hub Options .....	Page F5-40, F5-41
Design Options.....	Page F5-42, F5-43
Bolt Thread Size .....	Page F5-44
Bolt/Nut Tightening Torque .....	Page F5-44
Application Data Sheet .....	Page F5-45, F5-46

# Product Features and Options

Features	Form-Flex®						Torsiflex-i
	A-Series		G-Series				TFI
	AR, AP AX, AY, AA	A5, A6, A7	GP	G5	GR	GCH, GCF, HSH, FSH	
<b>Standard Bore Fit:</b>	Clearance		Interference				
<b>Set Screws:</b>	Standard		Optional				
<b>Puller Holes:</b>	Optional						Standard
<b>Standard Flex Disc:</b>	300 Series Stainless Steel <sup>(1)</sup>					Alloy Steel <sup>(2)</sup>	300 Series SS
<b>Balance Class:</b>	AGMA 7	N/A	AGMA 8	N/A	AGMA 8	N/A	AGMA 9
<b>Dynamic Balance:</b>	Optional	Per TBW Commercial Standard	Optional	Per TBW Commercial Standard	Optional	N/A	Optional

(1) Stainless Steel is standard. Alloy Steel is optional.

(2) Alloy Steel is standard. Stainless Steel is optional.

## Form-Flex® Disc Coupling Advantages

- Over 40 years experience in flexible disc couplings
- All metal Construction
- No Lubrication
- No Moving Parts
- Long Life
- High Torsional Stiffness
- Precise Positioning - Zero Backlash

## Applications

Flexible Disc couplings can be used in a wide variety of applications from general industrial equipment to high speed precision machines. They are one of the most versatile coupling designs and can be customized to meet the demands of almost every application. Some of the applications in which Flexible Disc couplings can be used are:

- General Purpose & API610 Pumps
- Centrifugal & Screw Compressors
- Reciprocating Compressors
- Fans & Blowers
- Food Processing
- Machine Tools
- Cooling Towers
- Printing Presses
- Engine & Electric Motor Driven Applications
- Power Generation

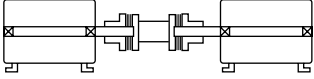
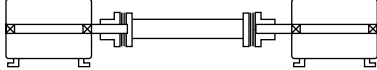
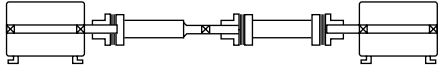
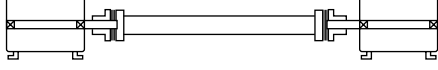
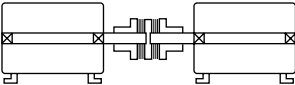
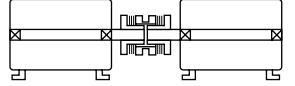
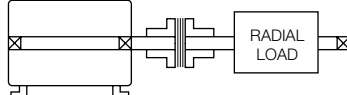
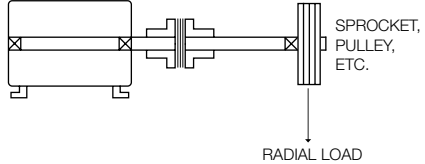

# Coupling Application Types Table

Coupling Type	Typical Applications	Series
<p><b>Spacer Couplings Double Flex</b></p>	<p>Spacer couplings are used to connect fully supported shafts with wider separations than can be reached with a close couple design. Spacer couplings allow room for installation and maintenance without moving the connected equipment. Shaft separations are generally in the range of 3 to 12 inches. These couplings accommodate angular, parallel and axial misalignment.</p>	 <p><b>AP, GP, TFI, GCF, GCH, FSH, HSH</b></p>
<p><b>Floating Shaft Coupling</b></p>	<p>Floating shaft couplings are spacer style couplings which are designed to connect widely separated shafts. The coupling spacers are fabricated. Both steel and TrueTube composite tubing options are available.</p> <p>Semi-floating shaft couplings are a special single flex version of the floating shaft coupling. These may be used alone for some applications or in combination with floating shaft couplings and pillow block bearings to span long distances.</p> <p>Composite floating shaft couplings should be considered as an alternative to multiple span applications with center bearings.</p>	   <p><b>A5, A5C, G5, B5C</b></p>
<p><b>Close Couple Double Flex</b></p>	<p>Close couple designs accommodate angular, parallel and axial misalignment types where two fully supported shafts are located very close together. Close shaft separations are generally in the range of 1/8 to 2 inches.</p>	  <p><b>AA, AX, AY</b></p>
<p><b>Single Flex</b></p>	<p>Single flexing couplings compensate for angular and axial misalignment only. Single couplings should only be used in a three bearing system with a self-aligning bearing as shown in the illustration. Single couplings may also be used in pairs to support a clutch, transducer or other system component. These arrangements are double flexing and must be used with two fully supported shafts as described below.</p>	  <p><b>AR, GR</b></p>

# Coupling Selection Process

1) Select correct Service Factor (S.F.) from the chart below.

2) Calculate HP/100 RPM or Design Torque (lb-in).

$$\text{HP/100 RPM} = \frac{\text{HP} \times \text{S.F.} \times 100}{\text{coupling RPM}}$$

OR

$$\text{Design Torque (lb-in)} = \frac{63025 \times \text{HP} \times \text{S.F.}}{\text{coupling RPM}}$$

OR

$$\text{Design Torque} = \text{Torque (lb-in)} \times \text{S.F.}$$

Calculate kW/100 RPM or Design Torque (Nm)

$$\text{kW/100RPM} = \frac{\text{kW} \times \text{S.F.} \times 100}{\text{coupling RPM}}$$

$$\text{Design Torque (Nm)} = \frac{9550 \times \text{kW} \times \text{S.F.}}{\text{coupling RPM}}$$

$$\text{Design Torque} = \text{Torque (Nm)} \times \text{S.F.}$$

3) Compare this to the HP/100 RPM (kW/100 RPM) column or the Rated Torque column.

4) Check other limiting factors such as max bores, minimum DBSE, max speed and overall dimensions.

Unit Conversions: HP x .746 = kW or kW x 1.34 = HP

Nm x 8.851 = lb-in or lb-in x .113 = Nm

## SERVICE FACTOR TABLE

These service factors assume a smooth motor or turbine type driver. The adders listed for other driver types must be added to the service factor shown for the driven equipment.

Adders For Driver Type		Driven Equipment	S.F.	Driven Equipment	S.F.	Driven Equipment	S.F.
DRIVER	ADD	CONVEYORS-Uniform load (Cont.)		FANS		PAPER MILLS-(Cont.)	
TURBINE	0	Flight	1.25	Centrifugal	1.00	Couch	1.75
AC MOTORS		Oven	1.50	Cooling Tower	2.00	Cutters, Platers	2.00
With Soft Start	0	Screw	1.25	FEEDERS		Cylinders	1.75
NEMA A or B, IEC N	0	CONVEYORS-Non-Uniform Load		Apron	1.25	Dryers	1.75
NEMA C or D, IEC H	1	Apron	1.50	Belt	1.25	Felt Stretchers	1.25
DC MOTORS		Assembly	1.25	Disc	1.25	Felt Whipper	2.00
Shunt Type	0	Belt	1.25	Reciprocating	2.50	Presses	2.00
Series or Compound	1	Bucket	1.50	Screw	1.25	Reel	1.50
I/C ENGINES		Chain	1.50	FOOD INDUSTRY		Stock Chests	1.50
8 or More Cylinders	1	Flight	1.50	Cereal Cookers	1.25	Suction Roll	1.75
4-6 Cylinders	1.5	Oven	1.50	Dough Mixers	1.75	Washers and Thickeners	1.50
1-3 Cylinders	2	Reciprocating	2.50	Meat Grinders	1.75	Winders	1.50
		Screw	1.50	Slicers	1.75	PRINTING PRESSES	1.50
		Shaker	2.50	LUMBER INDUSTRY		PUMPS	
<b>Driven Equipment</b>	<b>S.F.</b>	CRANES AND HOISTS		Barkers-Drum Type	2.00	Centrifugal	1.00
AGITATORS		Main Cranes	2.00	Edger Feeders	2.00	Reciprocating	
Pure Liquids	1.00	Reversing	2.00	Live Rolls	2.00	Double Acting	2.00
Liquids and Solids	1.25	Skip Hoists	1.75	Log Haul	2.00	Single Acting 1-2 Cylinders	2.25
Liquids-Variable Density	1.25	Trolley Drive	1.75	Off Bearing Rolls	2.00	Single Acting 3+ Cylinders	1.75
BLOWERS		Bridge Drive	1.75	Planers	1.75	Rotary-Gear, Lobe, Vane	1.50
Centrifugal	1.00	Slope	1.50	Slab Conveyors	1.50	TEXTILE INDUSTRY	
Lobe	1.50	DREDGES		Sorting Table	1.50	Batchers	1.25
Vane	1.25	Cable Reels	1.75	Trimmer Feed	1.75	Calenders	1.75
BRIQUETTER MACHINE	1.00	Conveyors	1.50	MACHINE TOOLS		Card Machines	1.50
CAN FILLING MACHINE	1.00	Maneuvering Winches	1.75	Bending Roll	2.00	Cloth Finishing Machines	1.50
COMPRESSORS		Pumps	1.75	Plate Planer	1.50	Dry Cans	1.75
Centrifugal	1.25	Screen Drives	1.75	Spindle Drives	1.50	Dryers	1.50
Lobe	1.50	Stracers	1.75	Table/Axis Drives	1.25	Dyeing Machinery	1.25
Reciprocating	C/F	Utility Winches	1.50	Tapping Machines	2.50	Looms	1.50
CONVEYORS-Uniform Load		ELEVATORS		PAPER MILLS		Mangles	1.25
Apron	1.25	Bucket	1.75	Beater & Pulper	1.75	Nappers	1.25
Assembly	1.00	Centrifugal Discharge	1.50	Bleacher	1.00	Soapers	1.25
Belt	1.00	Freight	2.00	Calendars	2.00	Spinners	1.50
Bucket	1.25	Gravity Discharge	1.50	Converting Machines	1.50	Tinter Frames	1.50
Chain	1.25						

# Coupling Selection Guide

- 1) Consult factory for applications in shaded areas.
- 2) Torque ratings may vary by coupling series.
- 3) Use the 1.0 service factor column if a service factor was used in the HP/100 RPM calculation.

**Consult Altra Couplings Engineering**

**Not Recommended for these Applications**

Typical Application Conditions						
SMOOTH MOTOR OR TURBINE DRIVEN 	STEADY MOTOR OR TURBINE DRIVEN 	MODERATE MOTOR OR TURBINE DRIVEN 	MEDIUM MOTOR OR TURBINE DRIVEN 	HEAVY-HIGH TQ. MOTOR OR ENGINE DRIVEN 	EXTRA HEAVY ENGINE DRIVEN 	EXTREMELY HEAVY ENGINE DRIVEN 
SOFT START WITH STEADY LOAD	AVERAGE STARTING LOADS AND SLIGHT TORQUE VARIATIONS	ABOVE AVERAGE STARTING LOADS AND MODERATE LOAD VARIATIONS	HIGH STARTING TORQUES AND MEDIUM TO HEAVY LOAD VARIATIONS	MILD SHOCK LOADING ENGINES. DRIVING SMOOTH LOADS. EXTREME RELIABILITY	HEAVY SHOCK LOADING OR LIGHT REVERSING	EXTREME SHOCK LOADING. FREQUENT WIDE TORQUE VARIATIONS

Type/Size	Torque Rating				O.D. (in)	Service Factor						# of Bolts		
	HP / 100 RPM	Max Continuous (lb-in)	Peak Overload (lb-in)	Rated HP/100 RPM at Service Factor Shown										
				1.0		1.5	2.0	2.5	3.0	3.25	4.0			
Form-Flex® A-Series	05	0.48	300	600	2.65	0.48	0.32	0.24	0.19				4	
	10	1.27	800	1,600	3.19	1.27	0.85	0.63	0.51					
	15	2.50	1,575	3,150	3.65	2.50	1.67	1.25	1.00					
	20	3.49	2,200	4,400	4.08	3.49	2.33	1.75	1.40					
	25	6.03	3,800	7,600	4.95	6.03	4.02	3.01	2.41					
	30	11.00	6,930	13,860	5.63	11.00	7.33	5.50	4.40					
Form-Flex® G-Series	35	18.00	11,340	22,680	6.63	17.99	12.00	9.00	7.20				6	
	311	17.5	11,000	22,000	5.88	17.45	11.64	8.73	6.98	5.8	5.4			
	321	32.5	20,500	41,000	6.38	32.53	21.68	16.3	13.0	10.8	10			
	332	50.8	32,000	64,000	7.20	50.8	33.8	25	20	17	16			
	346	73.0	46,000	92,000	8.20	73.0	48.7	36	29	24	22			
	380	127	80,000	160,000	9.36	127	85	63	51	42	39			
	Form-Flex® G-Series	340	63.5	40,000	80,000	8.38	63.5	42.3	32	25	21	20	16	8
		412	190	120,000	240,000	11.00	190	127	95	76	63	59	48	
		419	301	190,000	380,000	12.50	301	201	151	121	100	93	75	
		424	476	300,000	600,000	15.00	476	317	238	190	159	146	119	
		444	690	435,000	870,000	16.38	690	460	345	276	230	212	173	
		456	889	560,000	1,120,000	18.00	889	592	444	355	296	273	222	
		483	1317	830,000	1,660,000	19.44	1317	878	658	527	439	405	329	
		511	1745	1,100,000	2,200,000	22.00	1745	1164	873	698	582	537	436	
520		3173	2,000,000	4,000,000	24.88	3173	2116	1587	1269	1058	976	793		
525		3967	2,500,000	5,000,000	26.75	3967	2644	1983	1587	1322	1221	992		
530		4760	3,000,000	6,000,000	28.00	4760	3173	2380	1904	1587	1465	1190		
540		6347	4,000,000	8,000,000	33.50	6347	4231	3173	2539	2116	1953	1587		
Torsiflex-i TFI		17	2.4	1,504	2,632	2.87	2.39	1.59	1.19	0.95	0.80	0.73		6
		27	3.8	2,390	4,183	3.35	3.79	2.53	1.90	1.52	1.26	1.17		
	38	5.3	3,363	5,885	4.21	5.34	3.56	2.67	2.13	1.78	1.64			
	140	19.7	12,391	21,684	5.00	19.66	13.1	9.83	7.86	6.6	6.0			
	260	36.5	23,031	40,304	6.06	36.54	24	18.3	14.6	12	11			
	400	56.2	35,404	61,957	6.93	56.2	37	28	22	19	17			
	Torsiflex-i TFI	750	105	66,383	116,170	7.99	105	70	53	42	35	32		8
		1310	184	115,948	202,909	9.49	184	123	92	74	61	57		
		1900	267	168,169	294,296	10.98	267	178	133	107	89	82		
		2500	351	221,275	387,231	11.65	351	234	176	140	117	108		
		3300	463	292,083	511,145	12.84	463	309	232	185	154	143		
		6000	843	531,060	929,355	15.55	843	562	421	337	281	259		
		8500	1194	752,335	1,316,586	17.44	1194	796	597	477	398	367		
		12000	1685	1,062,120	1,858,710	19.45	1685	1123	843	674	562	519		
Form-Flex® (HSH/FSH)		22	15.1	9,500	14,250	6.00	15.07	10.05	7.54	6.03	5.02	4.64	3.8	8
		26	25.4	16,000	24,000	6.87	25.39	16.9	12.7	10.2	8.5	7.8	6	
		31	38.1	24,000	36,000	8.12	38.08	25	19.0	15.2	13	12	10	
		35	69.8	44,000	66,000	9.12	69.8	47	35	28	23	21	17	
		37	95.2	60,000	90,000	10.06	95.2	63	48	38	32	29	24	
		42	116	73,000	109,500	11.00	116	77	58	46	39	36	29	
	45	157	99,000	148,500	11.44	157	105	79	63	52	48	39		
	50	203	128,000	192,000	13.00	203	135	102	81	68	62	51		
	55	300	189,000	283,500	15.00	300	200	150	120	100	92	75		
	60	414	261,000	391,500	16.00	414	276	207	166	138	127	104		
	70	658	415,000	622,500	18.50	658	439	329	263	219	203	165		
	75	846	533,000	799,500	20.00	846	564	423	338	282	260	211		
	80	1087	685,000	1,027,500	22.00	1087	725	543	435	362	334	272		
	85	1315	829,000	1,243,500	23.75	1315	877	658	526	438	405	329		
	92	1650	1,040,000	1,560,000	25.75	1650	1100	825	660	550	508	413		
	92HT	2221	1,400,000	2,100,000	25.75	2221	1481	1111	889	740	683	555		



# Standard Bore Tolerances

## Imperial Standard Bore and Keyway Info

### Recommended Bore Tolerance for Imperial Shafts (Inches)

Nominal Shaft Range		Shaft Tol.	Interference Fit Bore Tol.	Clearance Fit Bore Tol.
Over	To (Incl.)			
.4375	1.5	+.0000 / -.0010	-.0005 / -.0010	+0.0010 / -.0000
1.5	2		-.0010 / -.0020	+0.0010 / -.0000
2	3		-.0010 / -.0020	+0.0015 / -.0000
3	4		-.0015 / -.0030	
4	5		-.0020 / -.0035	
5	7		-.0025 / -.0040	
7	8		-.0030 / -.0050	N/A
8	9		-.0035 / -.0055	N/A
9	10		-.0040 / -.0060	N/A

Reference AGMA 9002-B04

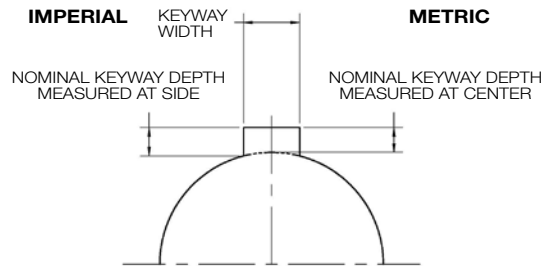

### Recommended Hub Keyway Dimensions (Inches)

Nominal Bore Range		Key Dims.		
Over	To (Incl.)	Width	Depth Square Key	Depth Reduced Key
0.312	0.438	0.094	0.047	-
0.438	0.562	0.125	0.063	0.047
0.562	0.875	0.188	0.094	0.062
0.875	1.250	0.25	0.125	0.094
1.250	1.375	0.312	0.156	0.125
1.375	1.750	0.375	0.188	0.125
1.750	2.250	0.500	0.250	0.188
2.250	2.750	0.625	0.313	0.219
2.750	3.250	0.750	0.375	0.250
3.250	3.750	0.875	0.438	0.313
3.750	4.500	1.000	0.500	0.375
4.500	5.500	1.250	0.625	0.438
5.500	6.500	1.500	0.750	0.500
6.500	7.500	1.750	0.875	0.750
7.500	9.000	2.000	1.000	0.750
9.000	11.000	2.500	1.250	0.875

Standard keyway fit is Commercial Class per AGMA 9002-B04

## Metric Standard Bore and Keyway Info

### Recommended Bore Tolerance for Metric Shafts (mm)

Nominal Shaft Range		Shaft Tol.	Shaft Des.	Clearance Fit		Interference Fit	
Over	To (Incl.)			Bore Tol.	Bore Des.	Bore Tol.	Bore Des.
12	18	+.008 / -.003	j6	+0.016 / +0.034	F7	-.015 / -.004	M6
19	30			+0.020 / +0.041	F7	-.017 / -.004	M6
32	50	+.018 / +.002	k6	+0.025 / +0.050	F7	-.013 / +0.003	K6
55	80			+0.030 / +0.060	F7	-.021 / +0.009	K7
85	100	+.035 / +0.013	m6	+.036 / +0.071	F7	-.035 / +0.000	M7
110	120					-.059 / -.024	P7
125	180	+.040 / +0.015		+0.043 / +0.083	F7	-.068 / -.028	P7
190	200			+.046 / +0.017	+.050 / +0.096	F7	-.079 / -.033
210	225	-.109 / -.063					R7
230	250	-.113 / -.067					R7
260	280	+.052 / +0.020		+0.056 / +0.108	F7	-.126 / -.074	R7

Reference AGMA 9112-A04

### Recommended Hub Keyway Dimensions (mm)

Nominal Bore Range		Nominal Key Size	Hub Keyway		
Over	To (Incl.)		Width	Depth	
				Nominal	Nominal
10	12	4X4	4	1.8	
12	17	5X5	5	2.3	
17	22	6X6	6	2.8	
22	30	8X7	8	3.3	
30	38	10X8	10	3.3	
38	44	12X8	12	3.3	
44	50	14X9	14	3.8	
50	58	16X10	16	4.3	
58	65	18X11	18	4.4	
65	75	20X12	20	4.9	
75	85	22X14	22	5.4	
85	95	25X15	25	5.4	
95	110	28X16	28	6.4	
110	130	32X18	32	7.4	
130	150	36X20	36	8.4	
150	170	40X22	40	9.4	
170	200	45X25	45	10.4	
200	230	50X28	50	11.4	
230	260	56X32	56	12.4	
260	290	63X32	63	12.4	

Standard metric keyway width tolerance per Js9

# Engineering Standards

## INDUSTRY STANDARDS REFERENCED

AGMA 9002-B04 - BORES AND KEYWAYS FOR FLEXIBLE COUPLINGS (INCH SERIES)  
 AGMA 9112-A04 - BORES AND KEYWAYS FOR FLEXIBLE COUPLINGS (METRIC SERIES)  
 AGMA 922-A96 - LOAD CLASSIFICATION AND SERVICE FACTORS FOR FLEXIBLE COUPLINGS  
 API610 / ISO 13709 - CENTRIFUGAL PUMPS FOR PETROLEUM, PETROCHEMICAL AND NATURAL GAS INDUSTRY, 11th Edition - Torsiflex-i meets the requirements of API610, 11th Edition when supplied with interference fit bores.  
 API671 / ISO 10441 - SPECIAL PURPOSE COUPLINGS FOR PETROLEUM, CHEMICAL AND GAS INDUSTRY SERVICES, 4th Edition  
 NEMA MG1 14.38, MG1 20.81 AND MG1 21.82 - All Form-Flex® & Torsiflex-i flexible disc couplings meet these standards without the addition of a limited end float device.

Certain tables and data in this catalog were extracted from the reference AGMA standards with the permission of the publisher, the American Gear Manufacturers Associations, 1901 North Meyer Drive, Arlington, VA 22209.

## DYNAMIC BALANCING RECOMMENDATIONS

Use this graph to determine the appropriate balance class based on coupling weight and operating speed. The balance classes listed on the graph are for equipment with average sensitivity to coupling unbalance. The user should determine how sensitive the equipment train is to coupling unbalance. Use one balance class higher if your system has higher than average sensitivity to unbalance. Use one balance class lower if your system has lower than average sensitivity to unbalance. Use this guide to check your coupling selection against the recommended balance class for your operating conditions.

The following factors should be considered when determining a machine's sensitivity to coupling unbalance.

- 1) Shaft End Deflection: Machines having flexible shaft extensions are relatively sensitive to coupling unbalance.
- 2) Bearing Load Due to Coupling Weight Relative to Total Bearing Load: Machines having lightly loaded bearings, bearings that are primarily loaded by the weight of the coupling or other overhung weight are relatively sensitive to coupling unbalance.
- 3) Bearing, Bearing Support and Foundation Flexibility: Machines or systems with flexible foundations for supports for the rotating elements are relatively sensitive to coupling unbalance.
- 4) System Natural Frequencies: Machines operating at or near natural frequencies are sensitive to coupling unbalance.
- 5) Machine Separation: System having widely separated machines are relatively sensitive to coupling unbalance.
- 6) Shaft Extension Relative to Bearing Span: Machines having a short bearing span relative to their shaft extensions are sensitive to static unbalance.

BALANCE CLASS SELECTION CHART

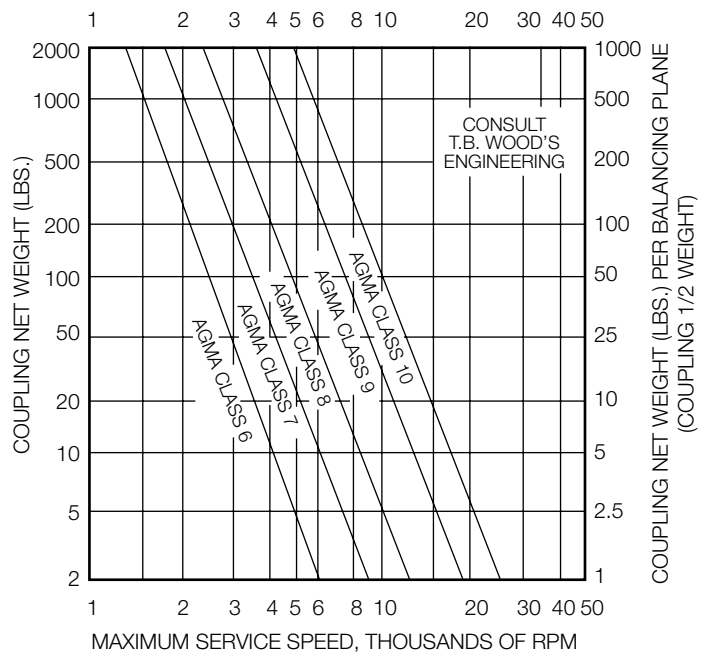

## HOW FLEXIBLE DISC COUPLINGS ACCOMMODATE MISALIGNMENT

Double flexing metal disc couplings may be used to accommodate angular, parallel and axial misalignment. Single flexing couplings may only be used to accommodate angular and axial misalignment. A metal disc type coupling uses a double hinge effect through two flexible discs and the spacer to compensate for parallel offset misalignment between shafts. Parallel misalignment imposes the same angular deflection (A) on each flex disc. Angular misalignment of either connected shaft, (B), creates additional angular deflections which are added to the angular offset due to parallel misalignment. The total misalignment angle, (C), at the flex disc is equal to the angular offset due to parallel misalignment (A) plus the angular offset due to angular misalignment (B). The maximum misalignment angle (C) should never exceed the rated misalignment capacity of the coupling type being used. Machinery equipment changes in actual operation and over the life of the equipment. We recommend that the machinery misalignment be set as close to zero as possible when a coupling is installed. We recommend keeping the measured misalignment below 25% of the rated misalignment capacity of the coupling type used when the machinery is installed and aligned. The remaining coupling misalignment capacity will then be available to accommodate additional misalignment caused by foundation shifts, vibrations, thermal growth or other causes.

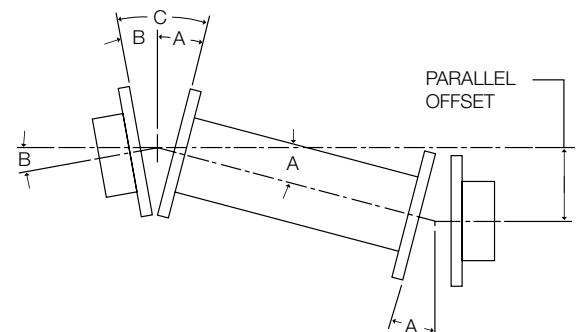

# Product Differentiation

Form-Flex® A - Series	Form-Flex® G - Series	Torsiflex-i TFI - Series
Higher bore capacity in low torque range	Higher Torque Density	Higher Torque Density and large bore capacity
1 ° Misalignment	.3 - .5 ° Misalignment	.3 - .5 ° Misalignment
Clearance Fit is standard	Interference Fit is standard	Interference Fit is standard
AGMA 7 balance class	AGMA 8 balance class	AGMA 9 balance class
Non-Unitized Flex Pack	Unitized Flex Pack	Factory assembled Transmission Unit
ATEX Group II/ Cat 3	ATEX Group II/ Cat 3	ATEX Group II/ Cat 2 Anti-Sparking design is standard
Low to Moderate Speeds	Low to Moderate Speeds	High to Moderate speeds

## DISC PACK DESIGN COMPARISON

**Form-Flex® G-Series  
Sizes 311-380**

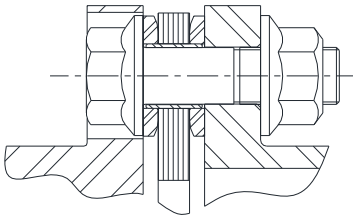

**UNITIZED**

- Disc pack force transferred to washer & hub interface
- Low bolt bending stress
- All torque transmitted through friction
- Higher torque capacity

**Form-Flex® G-Series  
Sizes 340 & 412-511**

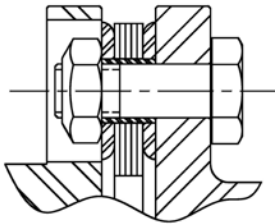

**Form-Flex® G-Series  
Sizes 517-540**

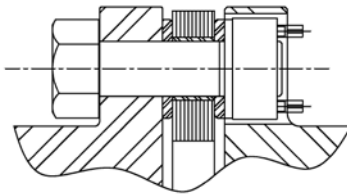

**Form-Flex®  
A-Series  
Sizes 5-35**

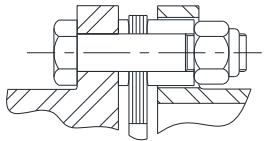

**Form-Flex®  
HSH/FSH**

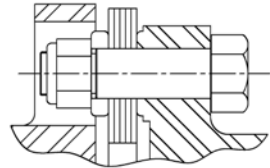

**NON-UNITIZED**

- Disc pack creates a bending moment on bolt
- High bolt bending stress
- Torque transmitted through shear and friction
- Lower torque capacity

## UNITIZED DISC DESIGNS

**Form-Flex®  
G-Series, Sizes 311-380  
(excluding 340)**

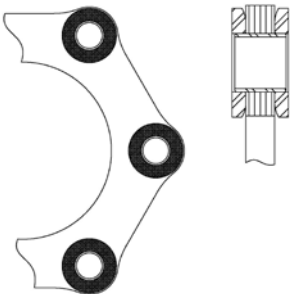

**Form-Flex®  
G-Series, Sizes 340 & 412-540**

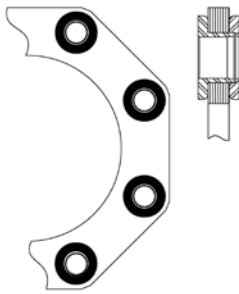

## NON-UNITIZED DISC DESIGNS

**Form-Flex®  
A-Series sizes 5-35**



**Torsiflex-i  
Sizes 27-1310**

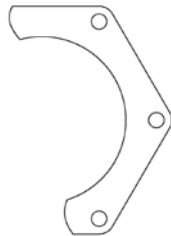

**Torsiflex-i  
Sizes 1900-1200**



**Form-Flex®  
HSH/FSH**



# Spacer Couplings

---

## PRODUCT DESCRIPTION

- Designed for moderate to higher speed applications
- Construction includes:
  - Two fully machined steel hubs
  - One fully machined steel spool spacer
  - Standard hardware and stainless steel disc packs
- Form-Flex® A-Series designs use non-unitized disc packs
- Form-Flex® G-Series designs use unitized disc packs
- Torsiflex-i designs use a drop out transmission unit with non-unitized disc packs
- Custom length spacer up to max DBSE
- Balancing and other modifications to suit your special system requirements
- Can be bored for any shaft configuration (F5-40 for hub design options)



## TYPICAL APPLICATIONS

- Pumps
- Centrifugal and Screw Compressors
- Fans and Blowers
- Mixers
- Turbo Compressors

## SPECIAL APPLICATIONS

- Test Stands
- Machine Tools / Positioning Systems
- Electrical Insulation

# Spacer Coupling AP Series - Form-Flex®

## Double Flex Spacer

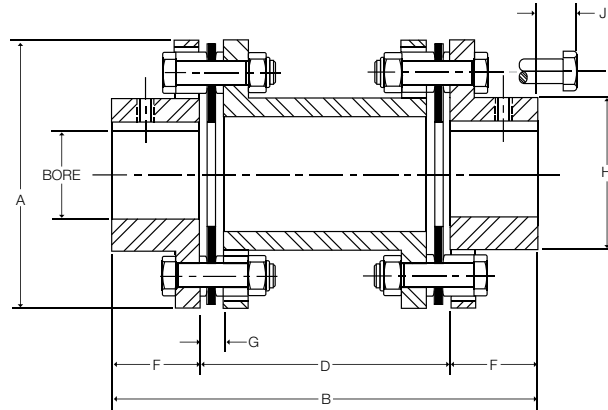

COUPLING CAN BE SUPPLIED TO API610 11TH EDITION

Size	Max Bore				Dimensions (in)								
	AJ		AZ		A	B		D DBSE		F	G	H	J
	(in)	(mm)	(in)	(mm)		Min	Max	Min	Max				
5	0.875	22	1.19	30	2.65	3.72	6.94	1.72	4.94	1.00	0.24	1.30	0.54
10	1.250	33	1.63	43	3.19	4.06	7.00	2.06	5.00	1.00	0.27	1.80	0.56
15	1.375	36	1.75	48	3.65	4.67	8.89	2.41	6.63	1.13	0.32	2.00	0.88
20	1.688	46	2.13	58	4.08	5.02	9.27	2.38	6.63	1.32	0.34	2.40	0.79
25	2.000	53	2.56	68	4.95	6.16	13.12	2.92	9.88	1.62	0.45	2.80	1.00
30	2.380	63	2.88	79	5.63	7.57	13.70	3.81	9.94	1.88	0.47	3.30	1.14
35	2.938	80	3.75	101	6.63	8.81	17.56	4.31	13.06	2.25	0.55	4.15	0.97

Dimensions are shown for standard AJ hubs unless otherwise specified.

Size	HP/100 RPM	Rated Torque (lb-in)	Peak O/L Torque (lb-in)	AGMA 7 Max RPM	Weight (lbs) (1)		WR <sup>2</sup> (lb-in <sup>2</sup> ) (1)		Misalignment Capacity	
					at D Min	Add Per Inch of D	at D Min	Add Per Inch of D	Axial (+/-in)	Angular (Degrees/Disc Pack)
5	0.48	300	600	8,500	2.32	0.14	1.87	0.05	0.030	1°
10	1.27	800	1,600	7,500	3.62	0.22	4.48	0.11	0.040	
15	2.5	1,575	3,150	6,700	5.44	0.26	8.86	0.19	0.042	
20	3.49	2,200	4,400	6,200	6.96	0.32	13.8	0.34	0.055	
25	6.03	3,800	7,600	5,500	12.7	0.41	38.8	0.62	0.060	
30	11	6,930	13,860	5,000	19	0.46	77.7	0.92	0.065	
35	18	11,340	22,680	4,400	27.6	0.63	156	2.29	0.085	

1) Weight and WR<sup>2</sup> values shown are for AJ hubs at max inch bore and spacer length at D Min

### STANDARD MATERIALS (CLASS A)

HUBS - CARBON STEEL  
 SPACER - CARBON STEEL  
 HARDWARE - ALLOY STEEL  
 DISC PACK - STAINLESS STEEL

### ORDERING

AP SERIES COUPLINGS ARE SOLD AS COMPONENTS  
 COUPLINGS CONSIST OF:  
 2 - HUBS - Example (AJ25A x 1-3/4")  
 1 - SPACER SUB-ASSEMBLY - Example for DBSE = 5.00"  
 (AP25A500)

### MATERIAL / FINISH OPTIONS

CLASS A - Steel hubs and spacer, alloy steel hardware, 300 series stainless steel disc pack  
 CLASS B - Zinc plated steel hubs, and spacer, alloy steel hardware, 300 series stainless steel disc pack  
 CLASS C - Zinc plated steel hubs, and spacer, stainless steel hardware, 300 series stainless steel disc pack  
 CLASS E - 300 series stainless steel hubs and spacer, stainless steel hardware, 300 series stainless steel disc pack  
 (Only available for sizes 15 thru 35)



# Spacer Coupling GP Series - Form-Flex®

## Double Flex Spacer

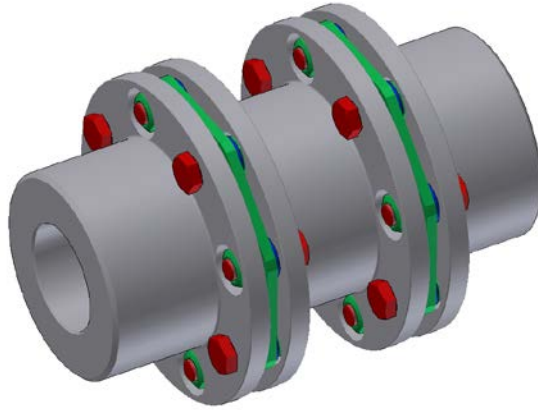

Size	Torque Rating			Max Speed (RPM)		Weight (lbs) (1)		WR <sup>2</sup> (lb-in <sup>2</sup> ) (1)		Misalign-ment Capacity	
	HP / 100 (RPM)	Max Continuous (lb-in)	Peak Overload (lb-in)	AGMA 8	ABS. Max	at D Min	Add Per Inch of D	at D Min	Add Per Inch of D	Axial (+/- in)	Angular (Degrees/ Disc Pack)
311	17	11,000	22,000	5,400	13,000	16.20	0.62	66.70	2.09	0.028	0.5°
321	33	20,500	41,000	4,900	12,000	25.75	0.66	123.01	2.54	0.029	
332	51	32,000	64,000	4,400	11,500	40.27	0.94	242.39	4.27	0.030	
346	73	46,000	92,000	4,100	9,000	54.42	1.03	429.27	6.94	0.050	
380	127	80,000	160,000	3,800	7,000	79.30	1.20	792.67	8.75	0.080	
412	190	120,000	240,000	3,500	6,000	110.1	1.45	1607.6	13.29	0.080	0.33°
419	301	190,000	380,000	3,000	5,000	197.8	2.32	3660.0	27.92	0.100	
424	476	300,000	600,000	2,750	5,000	287.6	3.08	8127.6	62.49	0.100	
444	690	435,000	870,000	2,500	4,000	413.3	3.38	13587	87.03	0.110	
456	1015	640,000	1,280,000	2,350	3,500	539	4.73	21896	133.5	0.120	
483	1317	830,000	1,660,000	2,200	3,500	727	5.36	33653	195.1	0.130	
511	1904	1,200,000	2,400,000	2,050	3,000	978	6.75	60082	310.3	0.140	
520	3173	2,000,000	4,000,000	1,750	2,500	1752	10.14	114979	586.5	0.180	
525	3967	2,500,000	5,000,000	1,700	2,500	2113	11.07	185975	762.5	0.200	
530	4760	3,000,000	6,000,000	1,600	2,500	2533	15.43	243383	1160.9	0.200	
540	6347	4,000,000	8,000,000	1,450	2,000	3831	19.23	557906	2247.7	0.240	

1) Weight and WR<sup>2</sup> values shown are for standard hubs at max inch bore and spacer length at D Min

### STANDARD MATERIALS

HUBS - CARBON STEEL

SPACER - CARBON STEEL

HARDWARE - ALLOY STEEL

DISC PACK - STAINLESS STEEL

### MATERIAL / FINISH OPTIONS

DISC PACK - ALLOY STEEL (For cost reduction, available for sizes 412 to 540)

ZINC ELECTRO PLATING

ZINC PHOSPHATE COATING

ALLOY STEEL HUBS

# Spacer Coupling GP Series - Form-Flex®

## Double Flex Spacer

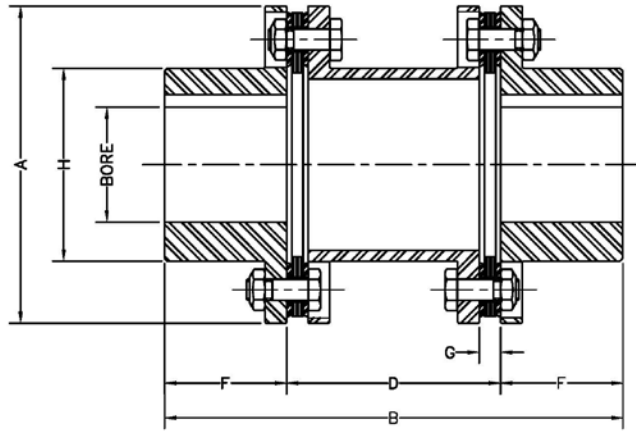

COUPLING CAN BE SUPPLIED TO API610 11TH EDITION

Size	Max Bore						Common Coupling Dimensions (in)								
	Standard Hub			Oversized/Large Hub			A	B		D DBSE		F	G	H	
	Square Key (in)	Rect. Key (in)	Rect. Key (mm)	Square Key (in)	Rect. Key (in)	Rect. Key (mm)		Min	Max	Min	Max			Std Hub	O/S Hub
311	2.813	3.063	78	3.125	3.313	86	5.88	8.06	17.75	3.06	12.75	2.50	0.40	3.91	4.30
321	3.000	3.250	83	3.250	3.438	90	6.38	10.13	19.06	4.13	13.06	3.00	0.55	4.25	4.57
332	3.188	3.313	87	3.438	3.688	95	7.20	12.00	19.19	5.00	13.19	3.50	0.61	4.50	4.95
346	3.750	4.000	107	4.250	4.500	117	8.20	12.50	25.19	5.00	19.19	3.75	0.62	5.42	5.95
380	3.750	4.000	105	4.250	4.500	118	9.42	15.00	28.00	6.75	19.75	4.13	0.89	5.65	6.30
412	4.500	4.500	120	4.750	5.125	135	11.00	14.19	27.94	5.69	19.44	4.25	0.75	6.51	7.20
419	4.500	4.875	130	5.500	5.625	150	12.50	17.69	29.94	7.69	19.94	5.00	0.98	7.32	8.07
424	6.625	6.880	190				15.00	20.19	32.44	7.69	19.94	6.25	0.98	9.57	
444	7.000	7.375	200				16.38	22.75	34.13	8.75	20.13	7.00	1.09	10.52	
456	8.000	8.000	220				18.00	24.31	35.13	9.81	20.63	7.25	1.32	11.63	
483	8.250	8.875	234				19.44	27.69	37.75	10.69	20.75	8.50	1.39	12.56	
511	10.000	10.125	280				22.00	29.69	39.06	11.69	21.06	9.00	1.56	14.50	
520	10.375	11.000	297				24.88	38.50	45.50	14.75	21.75	11.88	1.89	16.10	
525	11.000	12.000	322				26.75	39.38	45.88	15.38	21.88	12.00	1.95	17.35	
530	11.500	12.750	338				28.00	41.88	47.75	16.38	22.25	12.75	2.14	18.35	
540	15.750	17.000	448				33.50	49.00	54.13	19.00	24.13	15.00	2.58	22.63	

### ORDERING

GP SERIES COUPLINGS ARE SOLD AS COMPLETE ASSEMBLIES  
 PLEASE SPECIFY BORE SIZES, DISC PACK MATERIAL AND DBSE.  
 A COUPLING WILL BE CONFIGURED TO MEET YOUR SPECIFICATIONS.

# Pump Spacer Coupling TFI Series - Torsiflex-i

## API610/ISO13709 | Double Flex Spacer

### Torsiflex-i Disc Couplings Specifically designed for the process pump and general industrial markets.

The TFI coupling is specifically designed for the process pump and general industrial applications. It is comprised of two fully machined steel hubs, and a factory assembled drop out transmission unit. Standard spacer lengths are stock or it can be ordered for any custom spacing. This coupling is suitable for moderate to high speed operation on a wide range of general purpose motor and turbine driven equipment, including pumps, compressors and fans.



#### Advantages

- Standard coupling is fully compliant with the requirements of API610/ISO13709 & ISO14691
- Max bores matched to NEMA motor shafts, resulting in up to 60% weight savings per application
- Smaller diameter and lower weight per HP provide better inherent balance
- Plug-in spacer design allows installation and removal without disturbing the hubs
- Robust disc pack design allows for greater torque load in a smaller coupling, resulting in lower weight
- Large bolts for high clamp load, increasing frictional torque load, and reduced bolt bending stress
- ATEX compliance is standard — ExII 2GDc135degC(T4)
- Built-in Anti-Flail Feature
- Large hubs available on first three sizes
- Compliance with API 671/ISO 10441 is available

#### Standard Materials

Hubs - Carbon Steel  
Adapters - Carbon Steel  
Spacer - Carbon Steel  
Disc Pack - Stainless Steel  
Hardware - Alloy Steel  
O/L Washers - High Strength  
“Non-Sparking” Material

#### Standard Finish

Zinc phosphate coating on hubs, spacers and adapters.

#### Features

- Torsiflex-i couplings consist of 2 hubs and a factory assembled transmission unit. Installation involves fitting the hubs to the machinery shaft ends, introducing the transmission unit, then securing with the attachment screws
- MAXIMUM SPEEDS shown are for standard materials. When higher speeds are required please consult TB Woods Engineering.
- AGMA 9 BALANCE CLASS is met when hubs are bored for interference fit.
- PEAK TORQUE of 1.75 and MOMENTARY TORQUE of 2.7 times the stated ratings are accepted
- SPARK FREE overload protection is provided as a standard feature on all Torsiflex-i couplings, making them suitable for GAS ZONE environments
- STANDARD COUPLINGS are designed for general purpose applications and are suitable for the majority of process pump, fan, and compressors applications
- SPECIAL COUPLING versions available include:
  - Torque overload protection
  - Limited end float
  - Electrical Insulation
  - Bolted adapters suitable for high cyclic torques

#### Material / Finish Options

Disc Pack - Inconel  
Zinc Electro Plating  
Alloy Steel Hubs  
Welded Tube Spacer for Longer Spans

# Pump Spacer Coupling TFI Series - Torsiflex-i

## API610/ISO13709 | Double Flex Spacer

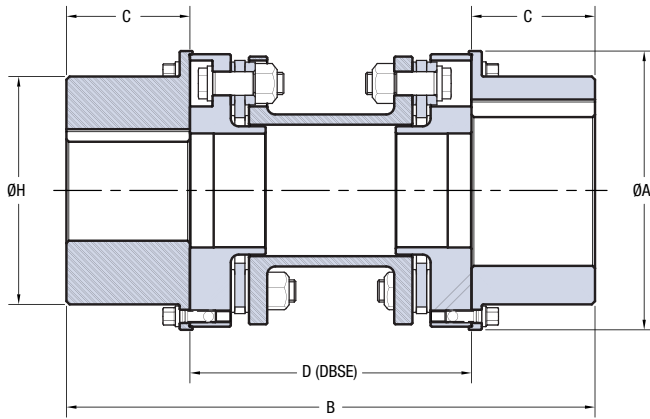

Standard Torsiflex-i Coupling

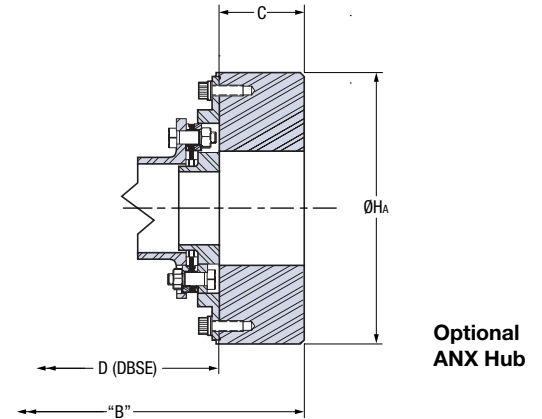

Optional ANX Hub

Size	Coupling Dimensions (in)						Max Bore						Stock Spacer Length (in) <sup>(2)</sup>							
	A	B	C	H	HA	Min DBSE <sup>(1)</sup>	Square Key			Reduced Key			3.50	4.38	5.00	5.50	7.00	7.50	8.00	9.00
							Standard Hub (in)	Large Hub (in)	ANX Hub (in)	Standard Hub (in / [mm])	Large Hub (in / [mm])	ANX HUB (mm)								
27	3.35	5.91	1.57	2.143	4.776	2.76	1.56	2.25	3.00	1.69 [42]	2.25 [57]	82	S	S	S	S	S	O	O	O
38	4.21	6.30	1.77	2.891	5.647	2.76	2.19	3.00	3.75	2.25 [58]	3.00 [76]	104	S	S	S	S	S	O	O	O
140	5.00	9.84	2.95	3.757	6.526	3.94	2.75	-	4.50	2.94 [75]	-	121		S	S	S	S	O	O	O
260	6.06	11.42	3.35	4.662	7.589	4.72	3.44	-	5.25	3.69 [95]	-	145			S	S	S	O	O	O
400	6.93	13.78	4.13	5.568	8.874	5.51	4.19	-	6.00	4.50 [116]	-	165					S	S	S	O
750	7.99	16.14	4.72	6.46	10.09	6.69	4.63	-	6.50	5.00 [132]	-	192					S	S	S	O
1310	9.49	19.29	5.71	7.76	11.567	7.87	5.63	-	7.50	6.13 [162]	-	226							S	S
1900	10.98	19.69	5.91	9.17	13.064	7.87	6.75	-	9.00	7.00 [192]	-	260							S	S
2500	11.65	21.57	6.46	9.45	13.733	8.66	6.88	-	9.50	7.13 [197]	-	276								S
3300	12.84	23.78	7.17	10.63	-	9.45	7.63	-	-	8.25 [220]	-	-								
6000	15.55	28.35	9.06	12.68	-	10.24	9.00	-	-	9.88 [265]	-	-								
8500	17.44	33.07	10.24	14.37	-	12.60	10.63	-	-	11.25 [302]	-	-								
12000	19.45	36.38	11.50	16.02	-	13.39	11.50	-	-	12.75 [337]	-	-								

\* For Large Hub H = A

(1) The inclusion of additional features such as packing rings, shims and/or electrical insulation will increase the minimum DBSE (Distance Between Shaft Ends)

(2) S = Stocked length ; O = Optional length

Size	Torque Rating		Max Speed RPM	Weight Transmission Unit (lb)			Weight Unbored Hub (lb) (3)			Angular Misalignment	Axial Deflection (in)
	HP / 100 RPM	(lb-in)		Wt @ Min DBSE	ANX Adder Per End	Extra Per (inch)	Standard	Large	ANX		
27	3.79	2,390	20,000	3.3	0.4	0.5	1.9	3.8	7.5	.5°	0.019
38	5.34	3,363	16,500	5.0	0.4	1.0	3.8	6.7	12.0		0.019
140	19.7	12,391	12,000	10.9	0.9	1.6	9.7	-	32.9		0.019
260	36.5	23,013	10,000	19.5	1.1	2.3	17.0	-	56.8		0.024
400	56.2	35,404	8,500	28.2	2.0	0.8	29.4	-	91.5		0.055
750	105	66,383	7,500	46.6	3.0	1.3	45.3	-	140		0.071
1310	184	115,948	6,500	79.7	3.9	1.5	78.9	-	214		0.087
1900	267	168,169	5,600	105	4.6	1.9	114	-	310	.33°	0.059
2500	351	221,275	5,200	134	4.0	2.2	133	-	376		0.067
3300	463	292,083	4,900	179	-	2.7	186	-	-		0.071
6000	843	531,060	4,000	283	-	4.1	333	-	-		0.094
8500	1194	752,335	3,600	439	-	5.4	485	-	-		0.11
12000	1685	1,062,120	3,000	578	-	7.7	686	-	-	0.118	

(3) For Finish Bore Hub weight = Weight Unbored hub - .222 \* Hub Length \* Bore Dia.^2

### ORDERING

TF SERIES COUPLINGS ARE SOLD AS COMPONENTS

COUPLINGS CONSIST OF:

2 - HUBS - Example (TFI0038 x 2.00 mm)

1 - TRANSMISSION UNIT - Example for DBSE = 5.00" (TFI0038SA500MM)

# Pump Spacer Coupling TFI Series w/ Torsi-Lock - Torsiflex-i

## API610/ISO13709 | Double Flex Spacer

- All Torsi-Lock devices must be sized to transmit the actual application Peak Torque. The data table shows a comparison of the Torsi-Lock torque transmissibility to the coupling Peak Torque Rating as a reference. The table below does not show all possible Torsi-Lock sizes and ranges. For any Torsi-Lock requirement beyond those detailed here, please consult TB Woods Engineering (see the catalog back cover for contact information).



- To determine the actual transmissible torque, as well as the actual combined hub plus Torsi-Lock device weight, from the data table, linearly interpolate between the range of values given for min and max shaft diameter. See the example interpolation calculation to the right.

- The data table is applicable to keyless shaft applications only. For keyed shaft applications, either:
  - Use a half key in the shaft and deduct the transmissible torque value of the Torsi-Lock by 10%
  - Use a full height key and the overkey dimension as the Shaft Size (dw) to determine the correct Torsi-Lock size.

Torsi-Lock Size				20	22	24	30	36	40	44	48	50	55	62	68	75	80	90	100																																												
Shaft Size Range	DW	Min (over)	in	0.630	0.709	0.787	0.827	1.024	1.220	1.339	1.417	1.575	1.654	1.890	2.047	2.362	2.559	2.756	2.953																																												
			mm	16	18	20	21	26	31	34	36	40	42	48	52	60	65	70	75																																												
		Max (incl)	in	0.709	0.787	0.827	1.024	1.220	1.339	1.417	1.575	1.654	1.890	2.047	2.362	2.559	2.756	2.953	3.150																																												
			mm	18	20	21	26	31	34	36	40	42	48	52	60	65	70	75	80																																												
Transmissible Torque (x1000)		TMin	lb-in	1.15	1.50	1.86	1.71	3.45	4.96	6.28	6.46	9.29	10.3	15.5	17.7	22.1	28.3	42.0	61.1																																												
		TMax	lb-in	1.59	2.04	2.21	3.36	5.58	7.08	7.61	9.82	12.2	16.6	19.9	27.9	35.0	40.7	64.2	79.7																																												
Torsi-Lock Device Dims	O.A.L.	L1	in	0.89	0.89	0.91	0.98	1.07	1.11	1.18	1.18	1.26	1.36	1.38	1.38	1.50	1.50	1.75	1.95																																												
	O.D.	Ht	in	1.89	1.89	1.97	2.36	2.83	2.95	3.15	3.15	3.54	3.94	4.33	4.53	5.43	5.71	6.10	6.69																																												
	Weight	Wt	lb	0.44	0.44	0.44	0.66	1.10	1.10	1.32	1.21	1.76	2.43	2.87	3.09	5.29	5.51	7.28	10.4																																												
Coupling Size	TFI0027			1.48	1.47	1.46	1.77	2.24	2.19	2.44	2.40	2.87	3.69																																																		
				1.44	1.43	1.44	1.64	2.07	2.08	2.36	2.21	2.76	3.33																																																		
				1.47	1.47	1.49	1.57	1.65	1.69	1.76	1.76	1.84	1.94																																																		
	TFI0038				2.57	2.56	2.87	3.32	3.25	3.49	3.44	3.89	4.70	5.14	5.43	7.53																																															
					2.53	2.53	2.72	3.13	3.12	3.40	3.23	3.77	4.30	4.84	4.76	7.04																																															
					1.65	1.67	1.75	1.83	1.87	1.94	1.94	2.02	2.12	2.14	2.14	2.26																																															
	TFI0140								3.79	4.04	3.99	4.46	5.29	5.76	6.08	8.23	8.40	10.8	14.8																																												
									3.67	3.95	3.80	4.35	4.92	5.48	5.47	7.78	7.91	10.2	14.1																																												
									1.69	1.76	1.76	1.84	1.94	1.96	1.96	2.08	2.08	2.33	2.53																																												
	TFI0260											6.29	6.74	7.55	7.99	8.28	10.4	10.5	12.9	16.8																																											
												6.08	6.62	7.16	7.69	7.62	9.89	9.98	12.3	16.1																																											
												1.94	2.02	2.12	2.14	2.26	2.26	2.51	2.71																																												
	TFI0400														9.69	9.99	12.1	12.2	14.6	18.5																																											
															9.40	9.32	11.6	11.7	14.0	17.8																																											
														2.14	2.14	2.26	2.26	2.51	2.71																																												
TFI0750																	15.8	18.2	22.1																																												
																	15.3	17.5	21.3																																												
																	2.38	2.63	2.83																																												
TFI1310																			25.4	29.2																																											
																			24.7	28.4																																											
																			2.80	2.99																																											
TFI1900			<b>Example (Coupling Size 1310):</b> <table border="1" style="width: 100%; text-align: center;"> <thead> <tr> <th>90</th> <th>100</th> <th>110</th> <th>115</th> <th>125</th> <th>140</th> <th>155</th> <th>165</th> <th>175</th> <th>185</th> <th>195</th> </tr> </thead> <tbody> <tr> <td>25.4</td> <td>29.2</td> <td>33.1</td> <td>33.5</td> <td>33.2</td> <td>38.4</td> <td>41.0</td> <td>48.9</td> <td>54.7</td> <td>63.0</td> <td>79.3</td> </tr> <tr> <td>24.7</td> <td>28.4</td> <td>32.1</td> <td>31.4</td> <td>30.8</td> <td>33.1</td> <td>36.4</td> <td>47.1</td> <td>50.8</td> <td>58.8</td> <td>74.3</td> </tr> <tr> <td>2.80</td> <td>2.99</td> <td>3.29</td> <td>3.45</td> <td>3.35</td> <td>3.35</td> <td>3.35</td> <td>3.80</td> <td>3.80</td> <td>3.80</td> <td>4.19</td> </tr> </tbody> </table>																	90	100	110	115	125	140	155	165	175	185	195	25.4	29.2	33.1	33.5	33.2	38.4	41.0	48.9	54.7	63.0	79.3	24.7	28.4	32.1	31.4	30.8	33.1	36.4	47.1	50.8	58.8	74.3	2.80	2.99	3.29	3.45	3.35	3.35	3.35	3.80	3.80	3.80	4.19
90	100	110	115	125	140	155	165	175	185	195																																																					
25.4	29.2	33.1	33.5	33.2	38.4	41.0	48.9	54.7	63.0	79.3																																																					
24.7	28.4	32.1	31.4	30.8	33.1	36.4	47.1	50.8	58.8	74.3																																																					
2.80	2.99	3.29	3.45	3.35	3.35	3.35	3.80	3.80	3.80	4.19																																																					
TFI2500																																																															
TFI3300																																																															
TFI6000																																																															
TFI8500																																																															
TFI12000																																																															



# Pump Spacer Coupling TFI Series w/ Torsi-Lock - Torsiflex-i

## API610/ISO13709 | Double Flex Spacer

### Example Interpolation Calculation

To interpolate Torsi-Lock table data for a TF 0260 with a size 115 Torsi-Lock for a bore of 3.625":

Y	Z	3.346	dw MIN (Min. Bore)	$\text{Target Weight } w = w1 + \frac{Z}{Y} (X)$ $W = 21.3 + \frac{(3.625 - 3.346)}{(3.74 - 3.346)} (21.3 - 19.3)$ $W = 19.9 \text{ (lbs)}$
		3.625	B (Target Bore)	
3.740	dw MAX (Max. Bore)			
X		21.3	w1 (Wt. @ dw MIN)	Where: Z = B - dw MIN Y = dw MAX - dw MIN X = w2 - w1
		W	(Target Wt.)	
		19.3	w2 (Wt. @ dw MAX)	

Note that the same method can be used to determine actual Torsiloc transmissible torque ratings for bores that are in between the min and max.

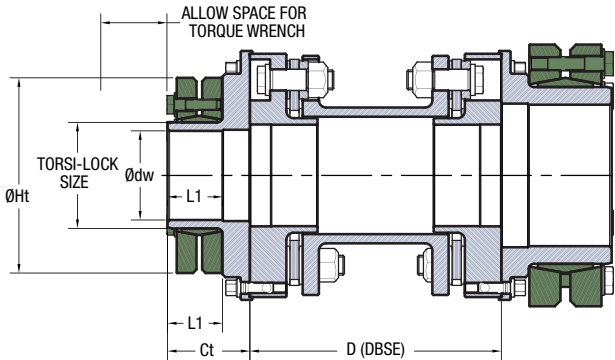

110	115	125	140	155	165	175	185	195	200	220	240	260	280	300	320	340	350	360	380	390
3.150	3.346	3.740	4.134	4.921	5.512	5.709	6.102	6.496	6.890	7.283	7.874	8.465	9.252	9.843	10.630	11.417	12.008	12.205	12.598	12.992
80	85	95	105	120	140	145	155	165	175	185	200	215	235	250	270	290	305	310	320	330
3.346	3.740	4.134	4.921	5.512	5.709	6.102	6.496	6.890	7.283	7.874	8.465	9.252	9.843	10.630	11.417	12.008	12.205	12.598	12.992	13.780
85	95	105	125	140	145	155	165	175	185	200	215	235	250	270	290	305	310	320	330	350
63.7	81.4	93.4	124	99	283	345	412	558	655	733	1,000	1,204	1,513	1,885	2,301	2,655	3,292	3,186	3,850	4,470
95.6	133	122	181	257	341	407	478	642	748	929	1,190	1,478	1,841	2,257	2,664	2,983	3,540	3,673	4,133	5,098
2.24	2.40	2.31	2.31	2.31	2.76	2.76	2.76	3.15	3.15	3.71	3.71	4.03	4.50	4.50	4.58	4.58	5.31	5.31	5.87	5.87
7.28	7.28	7.28	8.66	9.65	10.24	10.83	11.61	12.40	12.99	13.58	14.57	15.55	16.73	18.11	19.49	21.06	21.46	21.85	23.03	23.43
13.0	13.2	13.2	17.6	22.1	30.9	35.3	44.1	59.5	66.2	77.2	97.0	106	132	165	185	221	265	276	331	344
20.7	21.3																			
19.9	19.3																			
3.01	3.16																			
22.4	23.0	22.8	28.2																	
21.6	21.0	20.7	23.3																	
3.01	3.16	3.07	3.07																	
26.0	26.5	26.2	31.6	34.4																
25.1	24.4	24.0	26.5	30.0																
3.13	3.28	3.19	3.19	3.19																
33.1	33.5	33.2	38.4	41.0	48.9	54.7	63.0	79.3												
32.1	31.4	30.8	33.1	36.4	47.1	50.8	58.8	74.3												
3.29	3.45	3.35	3.35	3.35	3.80	3.80	3.80	4.19												
41.5	42.0	41.6	46.8	49.2	57.1	62.8	71.0	87.2	91.0	109										
40.6	39.8	39.2	41.3	44.5	55.1	58.8	66.7	82.2	85.7	98.9										
3.37	3.52	3.43	3.43	3.43	3.88	3.88	3.88	4.27	4.27	4.84										
	50.0	49.4	54.5	56.7	64.3	69.9	78.0	94.0	97.5	115	137									
	47.7	46.9	48.8	51.7	62.3	65.7	7.5	88.8	92.0	105	126									
	3.70	3.60	3.60	3.60	4.05	4.05	4.05	4.44	4.44	5.01	5.01									
			62.0	64.2	71.7	77.4	85.4	101	105	122	144	157								
			56.2	59.2	69.7	73.2	80.9	96.2	99.5	112	133	141								
			3.60	3.60	4.05	4.05	4.05	4.44	4.44	5.01	5.01	5.32								
				87.6	95.0	101	108	124	128	148	166	179	207	244	262					
				82.5	93.0	96.3	104	119	122	135	155	162	192	222	239					
				3.75	4.19	4.19	4.19	4.59	4.59	5.15	5.15	5.47	5.94	5.94	6.02					
					132	140	155	158	175	196	208	236	271	289	321	364	381			
					127	135	150	152	164	184	191	220	249	265	302	357	366			
					4.43	4.43	4.82	4.82	5.39	5.39	5.70	6.17	6.17	6.25	6.25	6.99	6.99			
								191	193	210	231	243	270	305	322	353	396	413	487	499
								185	187	199	219	225	254	282	297	334	389	397	470	463
								4.98	4.98	5.55	5.55	5.86	6.33	6.33	6.41	6.41	7.15	7.15	7.70	7.70

79.3 — Combined weight of the hub and Torsi-Lock device at the MIN shaft diameter.  
 74.4 — Combined weight of the hub and Torsi-Lock device at the MAX shaft diameter.  
 4.19 — Ct: Overall hub length thru bore (not including pilot lip)

# Floating Shaft Couplings

---

## PRODUCT DESCRIPTION

- Used for coupling spans that are greater than max catalog length for fully machined spacer designs
- Designed for moderate speed applications
- Construction includes:
  - Two fully machined steel hubs
  - One dynamically balanced welded or composite tube spacer
  - Standard hardware and stainless steel disc packs
- Form-Flex® A-Series designs use non-unitized disc packs
- Form-Flex® G-Series designs use unitized disc packs
- Spacers are configured for any custom length up to D-max shown per operating speed
- Can be bored for any shaft configuration (see page F5-40 for hub design options)

## TYPICAL APPLICATIONS

- Fans
- Turbo Compressors
- Vertical Pumping
- Cooling Tower
- Printing Press
- Paper Machines

## SPECIAL APPLICATIONS

- Mine Ventilation
- Dynamometers
- Test Stands
- Dredging Equipment
- Lift Tables

## DESIGN VARIATIONS

- A5/G5 - Welded Steel Tube
- A6/G6 - Welded Steel Tube - Vertical
- A7/G7 - Welded Steel Tube - Semi-Floating Spacer
- A5C/G5C - Composite Tube
- A6C/G6C - Composite Tube - Vertical
- A7C/G7C - Composite Tube - Semi-Floating

Large tube designs are available for speeds greater than catalog limits or for torsional tuning. Consult TB Wood's engineering for more info.



# Floating Shaft Spacer Coupling A5 Series - Form-Flex®

## Double Flex Floating Shaft

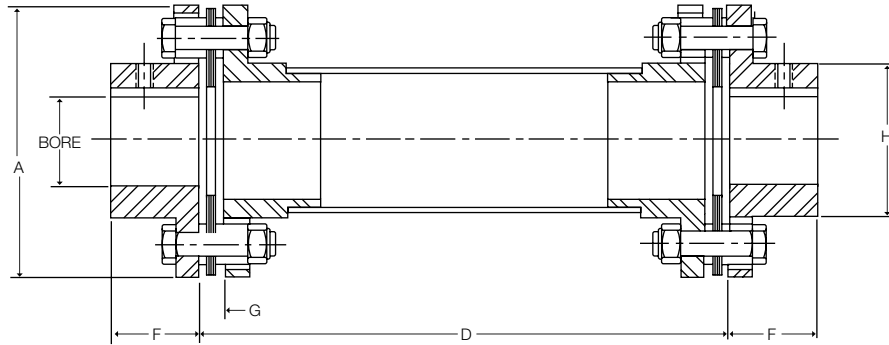

Size	Max Bore				Dimensions (in)					Max D (in) for RPM Shown					
	AJ		AZ		A	D Min	F	G	H	1800	1500	1200	900	750	600
	(in)	(mm)	(in)	(mm)											
5	0.875	22	1.19	30	2.65	4.94	1.00	0.24	1.30	51	56	62	71	78	87
10	1.250	33	1.63	43	3.19	5.00	1.00	0.27	1.80	62	69	76	88	96	107
15	1.375	36	1.75	48	3.65	6.63	1.13	0.32	2.00	64	71	79	91	99	111
20	1.688	46	2.13	58	4.08	6.63	1.32	0.34	2.40	73	81	90	103	113	126
25	2.000	53	2.56	68	4.95	9.88	1.62	0.45	2.80	79	87	97	112	122	137
30	2.380	63	2.88	79	5.63	9.94	1.88	0.47	3.30	85	94	102	120	132	147
35	2.938	80	3.75	101	6.63	13.06	2.25	0.55	4.15	97	107	119	137	150	168

Dimensions are shown for standard AJ hubs unless otherwise specified.

Size	HP/100 RPM	Rated Torque (lb-in)	Peak O/L Torque (lb-in)	Weight (lbs) (1)		WR <sup>2</sup> (lb-in <sup>2</sup> ) (1)		Misalignment Capacity	
				at D min	Add Per Inch of D	at D min	Add Per Inch of D	Axial (+/-in)	Angular (Degrees/Disc Pack)
5	0.48	300	600	2.71	0.11	1.93	0.03	0.030	1°
10	1.27	800	1,600	4.14	0.10	4.83	0.07	0.040	
15	2.5	1,575	3,150	6.14	0.10	9.36	0.07	0.042	
20	3.49	2,200	4,400	8.69	0.21	15.36	0.22	0.055	
25	6.03	3,800	7,600	14.98	0.20	42.07	0.29	0.060	
30	11	6,930	13,860	22.78	0.29	84.97	0.56	0.065	
35	18	11,340	22,680	32.02	0.40	170.84	1.32	0.085	

1) Weight and WR<sup>2</sup> values shown are for AJ hubs at max inch bore and spacer length at D Min

### STANDARD MATERIALS (CLASS A)

HUBS - CARBON STEEL

SPACER - CARBON STEEL

HARDWARE - ALLOY STEEL

DISC PACK - STAINLESS STEEL

### ORDERING

A5 Series couplings are sold as complete assemblies. Please specify hub types and bore sizes, DBSE (D) dimension, speed for dynamic balancing, and material class. A coupling will be configured to meet your specifications.

### MATERIAL / FINISH OPTIONS

CLASS A - Steel hubs and spacer, alloy steel hardware, 300 series stainless steel disc pack

CLASS B - Zinc plated steel hubs, and spacer, alloy steel hardware, 300 series stainless steel disc pack

CLASS C - Zinc plated steel hubs, and spacer, stainless steel hardware, 300 series stainless steel disc pack

CLASS E - 300 series stainless steel hubs and spacer, stainless steel hardware, 300 series stainless steel disc pack

(Only available for sizes 15 thru 35)

# Floating Shaft Spacer Coupling G5 Series - Form-Flex®

## Double Flex Floating Shaft



Size	Torque Rating			Weight (1) (lb)		WR <sup>2</sup> (1) (lb-in <sup>2</sup> )		Misalignment Capacity	
	HP / 100 (RPM)	Max Continuous (lb-in)	Peak Overload (lb-in)	at D Min	Add Per Inch	at D Min	Add Per Inch	Axial (+/- in)	Angular (Degrees/ Disc Pack)
311	17	11,000	22,000	22.67	0.39	86.75	1.28	0.028	0.5°
321	33	20,500	41,000	32.24	0.44	148.2	1.88	0.029	
332	51	32,000	64,000	47.06	0.47	271.2	2.24	0.030	
346	73	46,000	92,000	77.73	1.11	568.7	6.95	0.050	
380	127	80,000	160,000	102.5	1.17	944.6	8.04	0.080	
412	190	120,000	240,000	151.5	2.04	1,972.6	19.15	0.080	0.33°
419	301	190,000	380,000	248.2	2.21	4,137	24.24	0.100	
424	476	300,000	600,000	358.3	3.04	9,456	63.33	0.100	
444	690	435,000	870,000	502.2	3.38	15,621	86.52	0.110	
456	1015	640,000	1,280,000	633.6	4.89	24,595	147.92	0.120	
483	1317	830,000	1,660,000	880.0	5.11	37,972	169.02	0.130	
511	1904	1,200,000	2,400,000	1132	5.11	64,246	169.02	0.140	
520	3173	2,000,000	4,000,000	CONSULT TB WOOD'S				0.180	
525	3967	2,500,000	5,000,000					0.200	
530	4760	3,000,000	6,000,000					0.200	
540	6347	4,000,000	8,000,000					0.240	

1) Weight and WR<sup>2</sup> values shown are for standard at max inch bore and spacer length at D Min

### STANDARD MATERIALS

HUBS - CARBON STEEL

SPACER - CARBON STEEL

HARDWARE - ALLOY STEEL

DISC PACK - STAINLESS STEEL

### MATERIAL OPTIONS

DISC PACK - ALLOY STEEL (for cost reduction, only available on sizes 412 to 540)

ZINC ELECTRO PLATING

ZINC PHOSPHATE COATING

ALLOY STEEL HUBS

### DESIGN VARIATIONS

- G5 - Welded Steel Tube
- G6 - Welded Steel Tube—Vertical
- G7 - Welded Steel Tube—Semi-Floating Spacer
- G5C - Composite Tube
- G6C - Composite Tube—Vertical
- G7C - Composite Tube— Semi-Floating

# Floating Shaft Spacer Coupling G5 Series - Form-Flex®

## Double Flex Floating Shaft

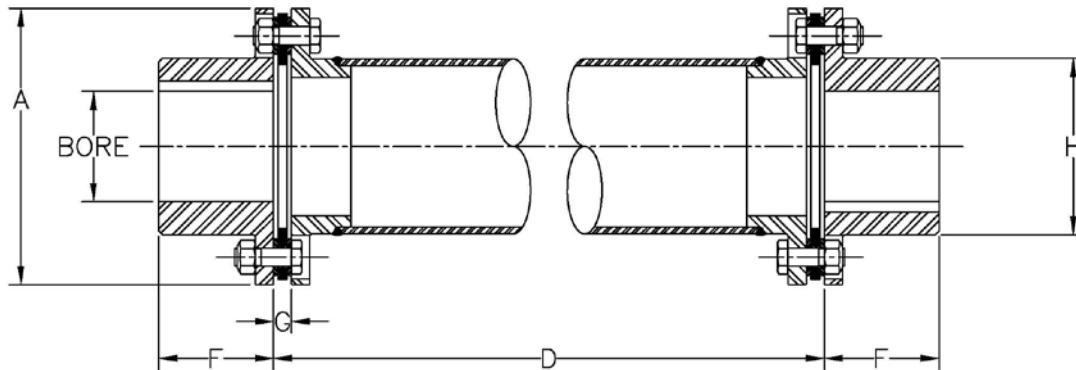

Size	Max Bore						Common Coupling Dimensions (in)								Max D (in) for RPM Shown					
	Standard Hub			Oversized/Large Hub			A	D Min	F	G	H		Tube		1800	1500	1200	900	750	600
	Square Key (in)	Rect. Key (in)	Rect. Key (mm)	Square Key (in)	Rect. Key (in)	Rect. Key (mm)					Std Hub	O/S Hub	OD	ID						
311	2.813	3.063	78	3.125	3.313	86	5.88	12.750	2.50	0.40	3.91	4.30	3.63	3.39	94	103	116	134	146	164
321	3.000	3.250	83	3.250	3.438	90	6.38	13.063	3.00	0.55	4.25	4.57	4.00	3.76	101	110	124	143	156	175
332	3.188	3.313	87	3.438	3.688	95	7.20	13.188	3.50	0.61	4.50	4.95	4.25	4.01	104	114	127	147	161	180
346	3.750	4.000	107	4.250	4.500	117	8.20	19.188	3.75	0.62	5.42	5.95	5.25	4.75	111	122	136	157	172	192
380	3.750	4.000	105	4.250	4.500	118	9.42	19.750	4.13	0.89	5.65	6.30	5.50	5.00	114	125	140	161	177	197
412	4.500	4.500	120	4.750	5.125	135	11.00	19.438	4.25	0.75	6.51	7.20	6.50	5.75	123	135	151	174	191	213
419	4.500	4.875	130	5.500	5.625	150	12.50	19.938	5.00	0.98	7.32	8.07	7.00	6.25	128	140	157	181	198	222
424	6.625	6.880	190				15.00	19.938	6.25	0.98	9.57		9.50	8.75	150	164	184	212	233	260
444	7.000	7.375	200				16.38	20.125	7.00	1.09	10.52		10.50	9.75	158	173	194	224	245	274
456	8.000	8.000	220				18.00	20.625	7.25	1.32	11.63		11.50	10.50	165	181	202	233	256	286
483	8.250	8.875	234				19.44	20.750	8.50	1.39	12.56		12.00	11.00	168	184	206	238	261	292
511	10.000	10.125	280				22.00	21.063	9.00	1.56	14.50		12.00	11.00	168	184	206	238	261	292
520	10.375	11.000	297				24.88	21.750	11.88	1.89	16.10									
525	11.000	12.000	322				26.75	21.875	12.00	1.95	17.35									
530	11.500	12.750	338				28.00	22.250	12.75	2.14	18.35									
540	15.750	17.000	448				33.50	24.125	15.00	2.58	22.63									

### ORDERING

G5 SERIES COUPLINGS ARE SOLD AS COMPLETE ASSEMBLIES  
 PLEASE SPECIFY BORE SIZES, DISC PACK MATERIAL AND DBSE.  
 A COUPLING WILL BE CONFIGURED TO MEET YOUR SPECIFICATIONS.



# Floating Shaft Spacer Coupling A5C/B5C Composite Series - Form-Flex®

## Double Flex Spacer

Form-Flex® flexible couplings may be mated to composite tubes for use as long floating shaft couplings. All types and most sizes of Form-Flex® couplings can be mated to composite tubes. Common combinations are shown below.

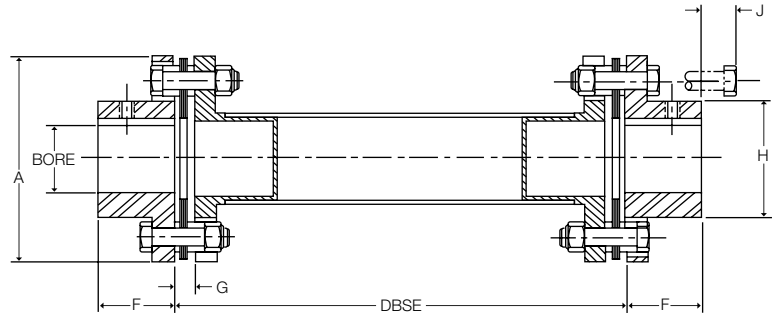

Type	Rated Torque*** lb-in	HP/ 100 RPM	Coupling Product No.	Maximum DBSE (in)			Maximum Bore			
				Max	@1800 RPM	@1500 RPM	Std Hub		AZ Hub	
							Square Key (in)	Reduced Key (in[mm])	Square Key (in)	Reduced Key (in[mm])
A5C20	2,200	3.49	A5C20_2G	84	72	79	1.625	1.75 [45]	2.125	2.188 [57]
			A5C20_2R	84	84*	84*				
A5C25	3,800	6.03	A5C25_2G	83	71	78	2.00	2.063 [52]	2.500	2.750 [68]
			A5C25_2R	83	83*	83*				
A5C30	6,930	11	A5C30_3R	130	107	117	2.375	2.438 [61]	2.875	3.063 [78]
			A5C30_3B	130	122	130*				
A5C35	11,340	18	A5C35_4R	147	123	135	2.875	3.125 [80]	3.750	3.75 [100]
			A5C35_4B	147	140	147*				
			A5C35_6R	152	149	152*				
			A5C35_6B	181	170	181*				
			A5C35_6BL	196	-	187				
			A5C35_8R	196	184	196*				
			A5C35_8B	196	196	196*				
			A5C35_8BL	236	-	215				
A5C40	18,270	29	A5C40_4R	147	123	135	3.250	3.375 [88]	4.000	4.375 [113]
			A5C40_4B	147	140	147*				
B5C58	34,000	54	B5C58_6R	181	149	151	4.000	4.250 [110]	5.000	5.500 [143]
			B5C58_6B	181	170	181*				
			B5C58_6BL	196	-	187				
			B5C58_6X	196	174	190				
			B5C58_8R	197	184	197*				
			B5C58_8B	197	196	197*				
			B5C58_8BL	237	-	215				
			B5C58_10B**	237	213	237*				
			B5C58_12B**	237	237*	237*				

Type	Coupling Product No.	Dimensions (in) (1)					Misalignment Capacity	
		A	F	G	H	J	Axial (+/- in)	Angular (Degrees/ Disc Pack)
A5C20	A5C20_2G	4.08	1.32	0.34	2.40	2.30	0.055	1°
	A5C20_2R					2.30		
A5C25	A5C25_2G	4.95	1.62	0.45	2.80	2.30	0.060	1°
	A5C25_2R					2.30		
A5C30	A5C30_3R	5.63	1.88	0.47	3.30	3.25	0.065	1°
	A5C30_3B					3.25		
A5C35	A5C35_4R	6.63	2.25	0.55	4.15	4.25	0.085	1°
	A5C35_4B					4.25		
	A5C35_6R					6.30		
	A5C35_6B					6.30		
	A5C35_6BL					6.30		
	A5C35_8R					8.31		
	A5C35_8B					8.31		
	A5C35_8BL					8.31		
A5C40	A5C40_4R	7.63	2.50	0.60	4.65	4.25	0.100	1°
	A5C40_4B					4.25		
B5C58	B5C58_6R	8.98	2.75	0.56	5.81	6.30	0.118	0.7°
	B5C58_6B					6.30		
	B5C58_6BL					6.30		
	B5C58_6X					6.30		
	B5C58_6XL					6.30		
	B5C58_8R					8.31		
	B5C58_8B					8.31		
	B5C58_8BL					8.31		
	B5C58_10B**					10.31		
	B5C58_12B**					12.31		

\* Length is restricted by available mandrels for winding composite tubes. Consult factory for longer lengths.

\*\* Tube diameter is larger than coupling "A" diameter. Consult factory for coupling drawing.

\*\*\* Peak Overload Torque Rating is 1.5 times Rated Torque

1) Dimensions are shown with standard hubs

# Floating Shaft Spacer Coupling A5C/B5C Composite Series - Form-Flex®

## QUICK SELECTION GUIDE FOR COOLING TOWER APPLICATIONS

1800 RPM				Coupling Model	1500 RPM			
DBSE		Max Power			Max Power		Max DBSE	
mm	in	Kw	HP		Kw	HP	mm	in
1828	72	23	31	A5C20_2G	20	26	2004	79
1802	71	40	54	A5C25_2G	34	45	1980	78
2133*	84*	23	31	A5C20_2R	20	26	2133*	84*
2108*	83*	40	54	A5C25_2R	34	45	2108*	83*
2723	107	74	99	A5C30_3R	62	82	2985	117
3101	122	74	99	A5C30_3B	62	82	3302*	130*
3130	123	121	161	A5C35_4R	100	134	3431	135
3129	123	194	260	A5C40_4R	162	217	3431	135
3564	140	121	161	A5C35_4B	100	134	3734*	147*
3563	140	194	260	A5C40_4B	162	217	3734*	147*
3799	149	121	161	A5C35_6R	100	134	3862*	152*
3807	149	362	485	B5C58_6R	302	404	3854	151
4327	170	121	161	A5C35_6B	100	134	4597*	181*
4337	170	362	485	B5C58_6B	302	404	4592*	181*
-	-	121	161	A5C35_6BL	100	134	4746	187
-	-	362	485	B5C58_6BL	302	404	4754	187
4423	174	362	485	B5C58_6X	302	404	4849	190
4671	184	121	161	A5C35_8R	100	134	4975*	197*
4682	184	362	485	B5C58_8R	302	404	5004*	197*
4975*	196*	121	161	A5C35_8B	100	134	4975	196
4974	196	362	485	B5C58_8B	302	404	5004*	197*
-	-	121	161	A5C35_8BL	100	134	5459	215
-	-	362	485	B5C58_8BL	302	404	5456	215
5414	213	362	485	B5C58_10B	302	404	6020*	237*
6020*	237*	362	485	B5C58_12B	302	404	6020*	237*

All sections use a 2.0 service factor

## ORDER CODE

### A5C35\_6B

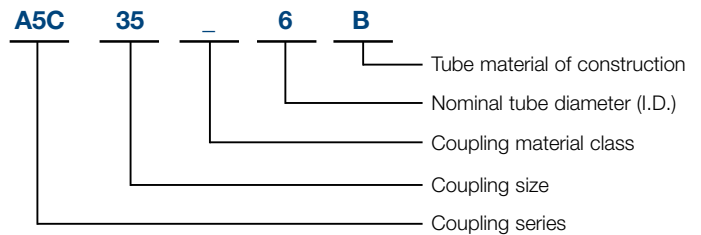

## COMPOSITE TUBE CONSTRUCTION

Model Code	Tube Material of Construction
G	GLASS
R	CARBON/GLASS HYBRID
B	STANDARD CARBON
X,Z	HIGH MODULUS CARBON

Material Class	Material Used		
	Hub	Hardware	Spacer Flanges
A	STEEL	STEEL	COMPOSITE OR STEEL
B	STEEL, ZINC PLATE	STEEL	COMPOSITE OR ZINC PLATED STEEL
C		304SS	
E	304SS	304SS	COMPOSITE OR 304SS

Metal spacer flanges used if composite is not available.

\* Length is restricted by available mandrels for winding composite tubes. Consult factory for longer lengths.

\*\* Tube diameter is larger than coupling "A" diameter. Consult factory for coupling drawing.

# Close Coupled Couplings

---

## PRODUCT DESCRIPTION

- Used for close shaft spacing where traditional spacer couplings cannot be used
- Designed for moderate speed applications
- Construction includes:
  - Two fully machined steel hubs
  - One flat bar or machined block style spacer
  - Standard hardware and stainless steel disc packs
- Form-Flex® designs use non-unitized disc packs

Spacers are configured for minimal shaft separation. Shorter shaft separation is possible by allowing the shafts to extend through the disc packs into the center of the coupling. The shaft diameter must be less than the flex pack I.D. listed in the dimensional table.



## TYPICAL APPLICATIONS

- Machine Tools
- Ball Screws
- Pumps
- Printing Machines

## SPECIAL APPLICATIONS

- Elastomeric Coupling Replacement
- Cranes
- Gear Coupling Replacement

# Close Coupled Coupling AX Series - Form-Flex®

## General Use - Double Flex Short Spacer

The AX series close coupling is made up of two hubs, a steel spacer block, two stainless steel disc packs and AX hardware. A special bolting arrangement supports the spacer between the flex discs. The AX is an economical design that is well suited to many general purpose applications. The AX accommodates close shaft separations when it is installed with the shafts extending through the flex discs into the center of the coupling. The shaft diameter must be less than the disc pack I.D. listed in the dimensional table.

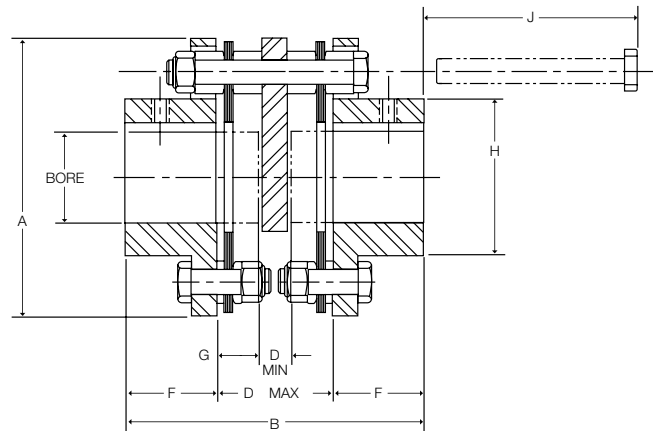

Size	Max Bore				Dimensions (in)*								
	AJ		AZ		A	B	DBSE		F	G	H	J	DISC PACK I.D.**
	(in)	(mm)	(in)	(mm)			D** Min	D Max					
5	0.875	22	1.19	30	2.65	3.34	0.38	1.34	1.00	0.48	1.30	1.68	1.00
10	1.250	33	1.63	43	3.19	3.40	0.44	1.40	1.00	0.48	1.30	1.79	1.17
15	1.375	36	1.75	48	3.65	3.80	0.63	1.54	1.13	0.44	2.00	1.85	1.28
20	1.688	46	2.13	58	4.08	4.22	0.63	1.58	1.32	0.48	2.40	1.66	1.65
25	2.000	53	2.56	68	4.95	5.36	0.75	2.12	1.62	0.69	2.80	2.39	1.78
30	2.380	63	2.88	79	5.63	6.30	1.00	2.54	1.88	0.77	3.30	3.18	2.01
35	2.938	80	3.75	101	6.63	7.17	1.13	2.67	2.25	0.77	4.15	2.81	2.71

\* Dimension shown are for AJ hubs unless otherwise specified.

\*\* Shaft O.D. must be less than Disc Pack I.D. in order to extend shafts into the coupling to meet D Min dimensions.

Size	HP/100 RPM	Rated Torque (lb-in)	Peak O/L Torque (lb-in)	Max RPM	Weight (lbs) (1)	WR <sup>2</sup> (lb-in <sup>2</sup> ) (1)	Misalignment Capacity	
							Axial (+/-in)	Angular (Degrees/Disc Pack)
5	0.48	300	450	8,500	1.63	1.26	0.030	1°
10	1.27	800	1,200	7,500	2.48	2.9	0.040	
15	2.5	1,575	2,363	6,700	3.84	5.8	0.042	
20	3.49	2,200	3,300	6,200	5.1	9.16	0.055	
25	6.03	3,800	5,700	5,500	9.13	26.1	0.060	
30	11	6,930	10,395	5,000	13.8	51.7	0.065	
35	18	11,340	17,010	4,400	21.1	108	0.085	

1) Weight and WR<sup>2</sup> values shown are for AJ hubs at max inch bore.

### STANDARD MATERIALS (CLASS A)

HUBS - CARBON STEEL

SPACER - CARBON STEEL

HARDWARE - ALLOY STEEL

DISC PACKS - STAINLESS STEEL

### ORDERING

AX SERIES COUPLINGS ARE SOLD AS COMPONENTS  
COUPLINGS CONSIST OF:

2 - HUBS - Example (AJ25A x 1-3/4")

1 - SPACER SUB-ASSEMBLY - Example (AX25SAA)

### STANDARD MATERIALS (CLASS B)

CLASS A - Mild steel hubs and spacer, alloy steel hardware, 300 series stainless steel disc packs

CLASS B - Zinc plated steel hubs, and spacer, alloy steel hardware, 300 series stainless steel disc packs

# Close Coupled Coupling AA Series - Form-Flex®

## General Use with Shorter Bolt Removal - Double Flex

The AA series close coupling is made up of two hubs, a cast iron block type spacer and two sets of standard hardware. Stainless steel disc packs are standard. The AA accommodates close shaft separations when it is installed with the shafts extending through the disc pack into the center of the coupling. The shaft diameter must be less than the disc pack I.D. listed in the dimensional table. This coupling is recommended when the bolt removal length (J) makes the AX coupling impractical.

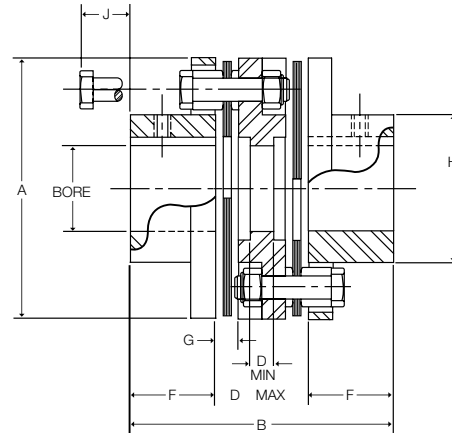

Size	Max Bore				Dimensions (in)*									Disc Pack I.D.**
	AJ		AZ		A	B	DBSE		F	G	H	J		
	(in)	(mm)	(in)	(mm)			D** Min	D Max						
5	0.875	22	1.19	30	2.65	3.23	0.25	1.23	1.00	0.24	1.30	0.54	1.00	
10	1.250	33	1.63	43	3.19	3.73	0.25	1.73	1.00	0.27	1.80	0.56	1.17	
15	1.375	36	1.75	48	3.65	3.82	0.31	1.56	1.13	0.32	2.00	0.88	1.28	
20	1.688	46	2.13	58	4.08	4.38	0.41	1.74	1.32	0.34	2.40	0.79	1.65	
25	2.000	53	2.56	68	4.95	5.26	0.41	2.02	1.62	0.45	2.80	1.00	1.78	
30	2.380	63	2.88	79	5.63	6.24	0.56	2.48	1.88	0.47	3.30	1.14	2.01	
35	2.938	80	3.75	101	6.63	6.91	0.66	2.41	2.25	0.55	4.15	0.97	2.71	

\* Dimension shown are for AJ hubs unless otherwise specified.

\*\* Shaft O.D. must be less than Disc Pack I.D. in order to extend shafts into the coupling to meet D Min dimensions.

Size	HP/100 RPM	Rated Torque (lb-in)	Peak O/L Torque (lb-in)	Max RPM	Weight (lbs) (1)	WR <sup>2</sup> (lb-in <sup>2</sup> ) (1)	Misalignment Capacity	
							Axial (+/-in)	Angular (Degrees/Disc Pack)
5	0.48	300	450	3,600	1.76	1.4	0.030	1°
10	1.27	800	1,200	3,500	2.77	3.35	0.040	
15	2.5	1,575	2,363	3,450	4.24	6.66	0.042	
20	3.49	2,200	3,300	3,350	5.48	10.2	0.055	
25	6.03	3,800	5,700	3,200	9.81	29.4	0.060	
30	11	6,930	10,395	3,000	15.0	59.0	0.065	
35	18	11,340	17,010	2,800	22.4	121	0.085	

1) Weight and WR<sup>2</sup> values shown are for AJ hubs at max inch bore.

### STANDARD MATERIALS (CLASS A)

HUBS - CARBON STEEL

SPACER - CARBON STEEL

HARDWARE - ALLOY STEEL

DISC PACK - STAINLESS STEEL

### ORDERING

AA SERIES COUPLINGS ARE SOLD AS COMPONENTS

COUPLINGS CONSIST OF:

2 - HUBS - Example (AJ25A x 1-3/4")

1 - SPACER SUB-ASSEMBLY - Example (AA25SAA)

### MATERIAL / FINISH OPTIONS

CLASS A - Steel hubs and spacer, alloy steel hardware, 300 series stainless steel disc pack

CLASS B - Zinc plated steel hubs, and spacer, alloy steel hardware, 300 series stainless steel disc pack

CLASS C - Zinc plated steel hubs, and spacer, stainless steel hardware, 300 series stainless steel disc pack

# Close Coupled Coupling AY Series - Form-Flex®

## Positioning Applications - Double Flex Short Spacer

The AY series is specifically designed for positioning applications where a servo or stepper drive is C flange mounted and connects to a ball screw. The AY accommodates the small amounts of angular and parallel misalignment with an absolute minimum size package, zero backlash and high torsional stiffness. The AY is made up of two hubs, a steel spacer block, two stainless steel disc packs and AY hardware. The coupling must be installed as an assembled unit. The spacer is not service removable.

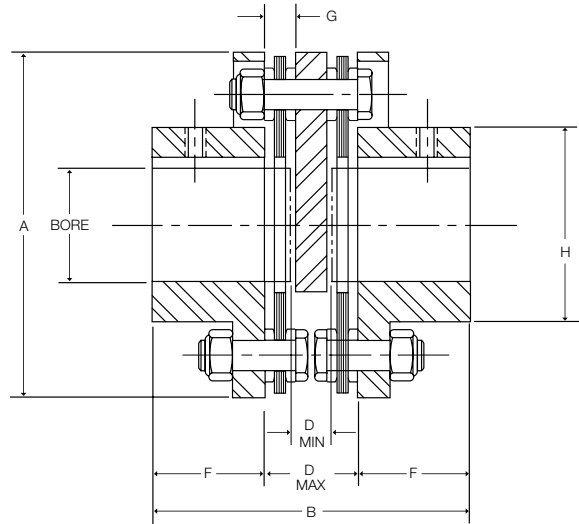

Size	Max Bore				Dimensions (in)*							
	AJ		AZ		A	B	DBSE		F	G	H	Disc Pack I.D.**
	(in)	(mm)	(in)	(mm)			D** Min	D Max				
5	0.875	22	1.19	30	2.65	2.85	0.49	0.85	1.00	0.24	1.30	1.00
10	1.250	33	1.63	43	3.19	2.91	0.50	0.91	1.00	0.27	1.80	1.17
15	1.375	36	1.75	48	3.65	3.33	0.56	1.07	1.13	0.32	2.00	1.28
20	1.688	46	2.13	58	4.08	3.76	0.56	1.12	1.32	0.34	2.40	1.65
25	2.000	53	2.56	68	4.95	4.77	0.87	1.53	1.62	0.45	2.80	1.78

\* Dimension shown are for AJ hubs unless otherwise specified.

\*\* Shaft O.D. must be less than Disc Pack I.D. in order to extend shafts into the coupling to meet D Min dimensions.

Size	HP/100 RPM	Rated Torque (lb-in)	Peak O/L Torque (lb-in)	Max RPM	Weight (lbs) (1)	WR <sup>2</sup> (lb-in <sup>2</sup> ) (1)	Misalignment Capacity	
							Axial (+/-in)	Angular (Degrees/Disc Pack)
5	0.48	300	600	8,500	1.64	1.24	0.030	1°
10	1.27	800	1,600	7,500	2.68	3.08	0.040	
15	2.5	1,575	3,150	6,700	4.23	6.41	0.042	
20	3.49	2,200	4,400	6,200	5.49	9.92	0.055	
25	6.03	3,800	7,600	5,500	9.78	27.6	0.060	

1) Weight and WR2 values shown are for AJ hubs at max inch bore.

### STANDARD MATERIALS (CLASS A)

HUBS - CARBON STEEL

SPACER - CARBON STEEL

HARDWARE - ALLOY STEEL

DISC PACK - STAINLESS STEEL

### ORDERING

AY SERIES COUPLINGS ARE SOLD AS COMPONENTS  
COUPLINGS CONSIST OF:

2 - HUBS - Example (AJ25A x 1-3/4")

1 - SPACER SUB-ASSEMBLY - Example (AY25SAA)

### MATERIAL / FINISH OPTIONS

CLASS A - Mild steel hubs and spacer, alloy steel hardware, 300 series stainless steel disc pack

CLASS B - Zinc plated steel hubs, and spacer, alloy steel hardware, 300 series stainless steel disc pack



# Single Flex Couplings

## PRODUCT DESCRIPTION

- Single Flex Couplings accommodate angular and axial misalignment only
- Construction includes:
  - Two fully machined steel hubs
  - Standard hardware and stainless steel disc packs
- Form-Flex® A-Series designs use non-unitized disc packs
- Form-Flex® G-Series designs use unitized disc packs
- Not intended for elastomeric coupling replacement
- Hubs can be single plane balanced for higher speed applications
- Can be bored for any shaft configuration (see page F5-40 for hub design options)

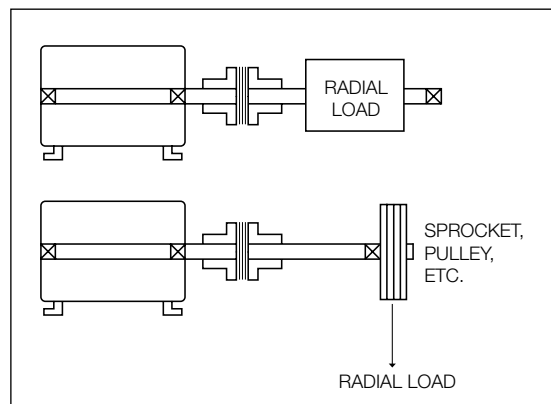

## TYPICAL APPLICATIONS

- Should only be used in three bearing system
- Used in pairs for floating shaft arrangement
- Can be used in pairs to support other components
  - Clutches
  - Brakes
  - Sheaves
- Mixers
- Single coupling can be used to support a component when a self-aligning bearing is used

## SPECIAL APPLICATIONS

- Torque Monitoring Equipment

# Single Flex Coupling AR Series - Form-Flex®

## Single Flex Short Spacing

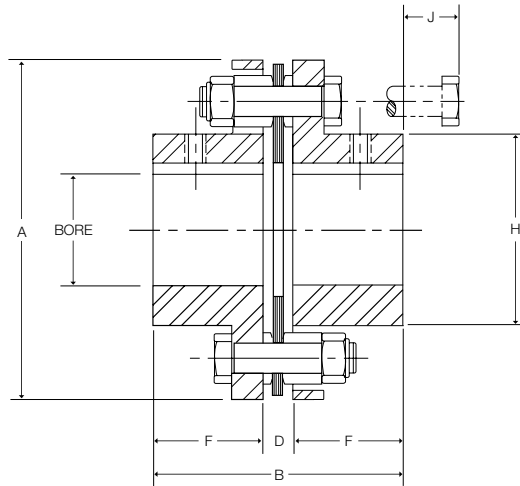

Size	Max Bore				Dimensions (in)*					
	AJ		AZ		A	B	D	F	H	J
	(in)	(mm)	(in)	(mm)			DBSE			
5	0.875	22	1.19	30	2.65	2.24	0.24	1.00	1.30	0.54
10	1.250	33	1.63	43	3.19	2.27	0.27	1.00	1.80	0.59
15	1.375	36	1.75	48	3.65	2.58	0.32	1.13	2.00	0.88
20	1.688	46	2.13	58	4.08	2.98	0.34	1.32	2.40	0.79
25	2.000	53	2.56	68	4.95	3.69	0.45	1.62	2.80	1.00
30	2.380	63	2.88	79	5.63	4.23	0.47	1.88	3.30	1.14
35	2.938	80	3.75	101	6.63	5.05	0.55	2.25	4.15	0.97

\* Dimension shown are for AJ hubs unless otherwise specified.

Size	HP/100 RPM	Rated Torque (lb-in)	Peak O/L Torque (lb-in)	AGMA 7 Max RPM	Max Radial Load (lbs)	Weight (1) (lbs)	WR <sup>2</sup> (1) (lb-in <sup>2</sup> )	Misalignment Capacity	
								Axial (+/-in)	Angular (Degrees/Disc Pack)
5	0.48	300	600	8,500	34	1.24	0.96	0.015	1°
10	1.27	800	1,600	7,500	56	1.96	2.35	0.020	
15	2.5	1,575	3,150	6,700	125	2.98	4.62	0.021	
20	3.49	2,200	4,400	6,200	183	4.07	7.48	0.027	
25	6.03	3,800	7,600	5,500	275	7.01	20.4	0.030	
30	11	6,930	13,860	5,000	400	10.8	41.5	0.032	
35	18	11,340	22,680	4,400	600	17.2	88.3	0.042	

1) Weight and WR<sup>2</sup> values shown are for AJ hubs at max inch bore.

### STANDARD MATERIALS (CLASS A)

HUBS - CARBON STEEL

SPACER - CARBON STEEL

HARDWARE - ALLOY STEEL

DISC PACKS - STAINLESS STEEL

### ORDERING

AR SERIES COUPLINGS ARE SOLD AS COMPONENTS

COUPLINGS CONSIST OF:

2 - HUBS - Example (AJ25A x 1-3/4")

1 - REPAIR KIT - Example (A25RKA)

### MATERIAL / FINISH OPTIONS

CLASS A - Steel hubs, alloy steel hardware, 300 series stainless steel disc packs

CLASS B - Zinc plated steel hubs and spacer, alloy steel hardware, 300 series stainless steel disc pack

CLASS C - Zinc plated steel hubs, stainless steel hardware, 300 series stainless steel disc packs

CLASS E - 300 series stainless steel hubs, stainless steel hardware, 300 series stainless steel disc packs

# Single Flex Coupling GR Series - Form-Flex®

## Single Flex Short Spacing



Size	Torque Rating			Max Speed (RPM)		Max Radial Load (lbs)	Weight (lbs) (1)	WR <sup>2</sup> (lb-in <sup>2</sup> ) (1)	Misalignment Capacity	
	HP / 100 (RPM)	Max Continuous (lb-in)	Peak Overload (lb-in)	AGMA 8	ABS. Max				Axial (+/- in)	Angular (Degrees/ Disc Pack)
311	17	11,000	22,000	8,000	13,000	360	11.0	41.5	0.014	0.5°
321	33	20,500	41,000	7,400	12,000	800	17.8	77.6	0.0145	
332	51	32,000	64,000	6,600	11,500	1,300	26.2	143	0.015	
346	73	46,000	92,000	6,100	9,000	1,300	38.1	271	0.025	
380	127	80,000	160,000	5,500	7,000	2,400	53.1	469	0.040	
412	190	120,000	240,000	5,200	6,000	2,400	72.5	935	0.040	0.33°
419	301	190,000	380,000	4,600	5,000	4,200	129.3	2092	0.050	
424	476	300,000	600,000	4,200	5,000	4,200	195.8	4936	0.050	
444	690	435,000	870,000	3,800	4,000	5,300	291.5	8422	0.055	
456	1015	640,000	1,280,000	3,600	3,500	6,700	364.0	13226	0.060	
483	1317	830,000	1,660,000	3,300	3,500	8,200	512.0	20843	0.065	
511	1904	1,200,000	2,400,000	3,100	3,000	9,800	677.2	37076	0.070	
520	3173	2,000,000	4,000,000	2,800	2,500	15,700	1208	71849	0.090	
525	3967	2,500,000	5,000,000	2,700	2,500	17,900	1473	113939	0.100	
530	4760	3,000,000	6,000,000	2,500	2,500	21,000	1752	148626	0.100	
540	6347	4,000,000	8,000,000	2,300	2,000	23,000	2662	346946	0.120	

1) Weight and WR<sup>2</sup> values shown are for standard hubs at max inch bore.

### STANDARD MATERIALS

HUBS - CARBON STEEL

SPACER - CARBON STEEL

HARDWARE - ALLOY STEEL

DISC PACKS - STAINLESS STEEL

### MATERIAL / FINISH OPTIONS

DISC PACKS - ALLOY STEEL (For cost reduction, available for sizes 412 to 540)

ZINC ELECTRO PLATING

ZINC PHOSPHATE COATING

ALLOY STEEL HUBS

# Single Flex Coupling GR Series - Form-Flex®

## Single Flex Short Spacing

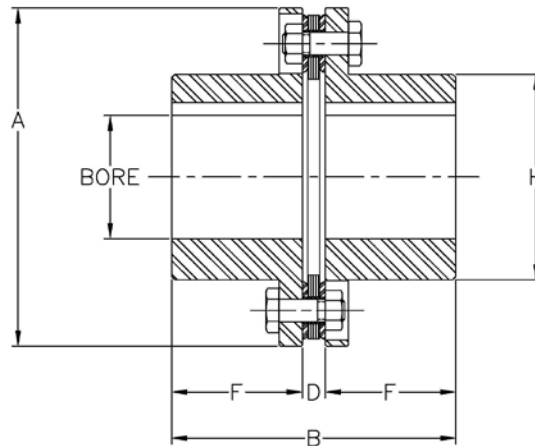

Size	Max Bore						Dimensions (in)					
	Standard Hub			Oversized/Large Hub			A	B	D DBSE	F	H	
	Square Key (in)	Rect. Key (in)	Rect. Key (mm)	Square Key (in)	Rect. Key (in)	Rect. Key (mm)					Std Hub	O/S Hub
311	2.813	3.063	78	3.125	3.313	86	5.88	5.40	0.40	2.50	3.91	4.30
321	3.000	3.250	83	3.250	3.438	90	6.38	6.55	0.55	3.00	4.25	4.57
332	3.188	3.313	87	3.438	3.688	95	7.20	7.62	0.62	3.50	4.50	4.95
346	3.750	4.000	107	4.250	4.500	117	8.20	8.12	0.62	3.75	5.42	5.95
380	3.750	4.000	105	4.250	4.500	118	9.42	9.14	0.89	4.13	5.65	6.30
412	4.500	4.500	120	4.750	5.125	135	11.00	9.25	0.75	4.25	6.51	7.20
419	4.500	4.875	130	5.500	5.625	150	12.50	10.98	0.98	5.00	7.32	8.07
424	6.625	6.880	190				15.00	13.48	0.98	6.25	9.57	
444	7.000	7.375	200				16.38	15.09	1.09	7.00	10.52	
456	8.000	8.000	220				18.00	15.82	1.32	7.25	11.63	
483	8.250	8.875	234				19.44	18.39	1.39	8.50	12.56	
511	10.000	10.125	280				22.00	19.56	1.56	9.00	14.50	
520	10.375	11.000	297				24.88	25.64	1.89	11.88	16.10	
525	11.000	12.000	322				26.75	25.95	1.95	12.00	17.35	
530	11.500	12.750	338				28.00	27.64	2.14	12.75	18.35	
540	15.750	17.000	448				33.50	32.58	2.58	15.00	22.63	

### ORDERING

GR SERIES COUPLINGS ARE SOLD AS COMPONENTS

COUPLINGS CONSIST OF:

2 - HUBS - Example (GH346 x 2-1/2")

1 - REPAIR KIT - Example (G346SF)

# Heavy Duty Spacer Coupling

## PRODUCT FEATURES

- Designed for low to medium speed equipment
- Standard designs for applications requiring shaft-to-shaft or shaft to flywheel connection.
- Construction
  - Fully machined steel hubs are standard
  - Ductile Iron or Class 30 Grey Iron spacer/spyder
  - Ductile Iron or Class 30 Grey Iron flywheel adapter
  - Alloy steel hardware and High Carbon steel disc packs
- Form-Flex® HSH/FSH Series designs use non-unitized disc packs
- Form-Flex® GCH/GCF Series designs use unitized disc packs
- Industry standard length spacer
- Can be bored for any shaft configuration (see page F5-41 for hub design options)
- Special flange mountings are also available to bolt custom flanges on any equipment.



## TYPICAL APPLICATIONS

- Reciprocating Compressors
- Metal Shredders
- Rock Crushers
- Engine Driven Equipment
- Mixer

## SPECIAL APPLICATIONS

- Can be modified for API671 with exceptions
- Added inertia to torsionally tune system
- Altered stiffness for torsional tuning
- Custom designs for demanding applications

## SPECIAL APPLICATIONS

Example: Coupling shown was specially designed for a high torque, low speed (10000HP @ 290RPM) application to torsionally tune the system. This is a 10 bolt disc pack design and the coupling is rated for 10,000,000 lb-in with an OD measuring 44.50". Flange mounted on both ends with a custom adapter hub on the motor's keyless shaft.



# Heavy Duty Spacer Coupling GCH Series - Form-Flex®

## Double Flex Spacer

Size	Spacer	Max Bore		Dimensions (in)					
		(in)	(mm)	A	B	D	F	G	H
340	31	3.75	100	8.38	9.89	4.14	2.88	0.57	5.44
	35				10.46	4.71			
412	42	4.50	120	11.00	14.07	5.57	4.25	0.75	6.51
	45				14.57	6.07			
	50				15.69	7.19			
424	55	6.88	190	15.00	19.95	7.45	6.25	0.98	9.57
	60				20.95	8.45			
456	70	8.00	220	18.00	24.13	9.63	7.25	1.32	11.63
	75				25.20	10.70			
511	80	10.00	280	22.00	29.39	11.39	9.00	1.56	14.50
	85				30.39	12.39			
	92				31.89	13.89			

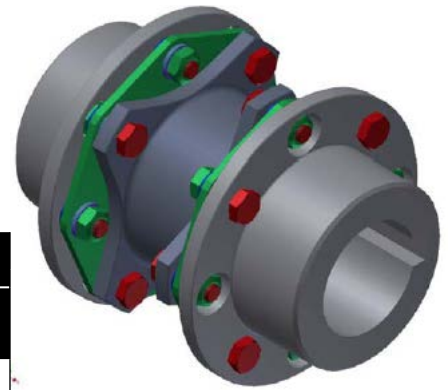
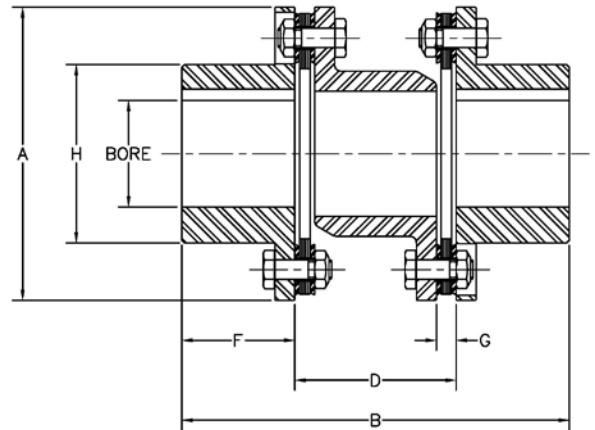

Size	Spacer	Rated Torque		Peak Overload (lb-in)	Max RPM	Weight (1) (lbs)	WR <sup>2</sup> (1) (lb-in <sup>2</sup> )	Misalignment Capacity	
		HP/100 RPM	(lb-in)					Axial +/- in	Angular (Degrees/Disc Pack)
340	31	64	40,000	60,000	3,400	43	344	0.06	0.33°
	35					44	349		
412	42	190	120,000	180,000	2,500	106	1,371	0.08	
	45					108	1,385		
	50					112	1,416		
424	55	380	240,000	360,000	1,800	278	7,141	0.10	
	60					284	7,259		
456	70	889	560,000	840,000	1,500	527	19,517	0.12	
	75					538	19,793		
511	80	1,746	1,100,000	1,650,000	1,200	964	54,373	0.14	
	85					980	55,013		
	92					1,108	64,414		

Note: Couplings available for torque capacity up to 1129815 Nm. Contact Altra Couplings engineering with application details for coupling selection.

### STANDARD MATERIALS

HUBS - CARBON STEEL

SPACER - DUCTILE IRON

HARDWARE - ALLOY STEEL

DISC PACKS - HIGH CARBON STEEL

### MATERIAL / FINISH OPTIONS

DISC PACKS - STAINLESS STEEL

ZINC PHOSPHATE COATING

ALLOY STEEL HUBS

STEEL SPACER

### NOTES:

- 1) Weight and WR<sup>2</sup> are calculated with hubs at maximum inch bore size.
- 2) Consult factory for torsional stiffness and alternating torque limits.

### ORDERING

GCH SERIES COUPLINGS ARE SOLD AS COMPLETE ASSEMBLIES

- 1) Specify coupling size and spacer option

Example: GCH424-60 5" x 6-1/4"

- 2) Specify hub bore size and tolerance, keyway size or keyless, special hub length, etc. Please specify for each hub.



# Heavy Duty Spacer Coupling GCF Series - Form-Flex®

## Double Flex Spacer

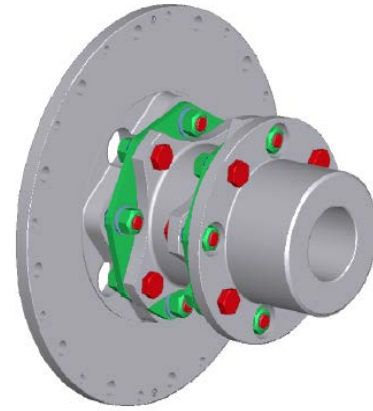
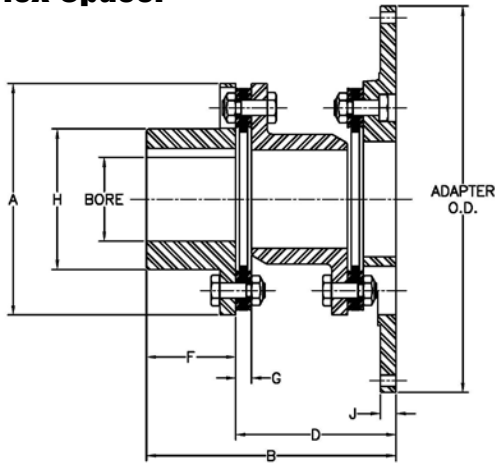

Size	Spacer	Max Bore		Dimensions (in)							Size	Adapter O.D. / Standard Bolt Pattern							
		(in)	(mm)	A	B	D	F	G	H	J		12.375	13.875	18.375	20.375	22.500	26.500	28.875	
340	31	3.75	100	8.38	8.19	5.31	2.88	0.57	5.44	0.5	340	12	14	18	20	22	26	28	
	35				8.76	5.88						Order	SAE	SAE	Order	SAE			
412	42	4.50	120	11.00	11.39	7.14	4.25	0.75	6.51	0.57	412			SAE	Order	SAE	SAE/HD	SAE/HD	
	45				11.89	7.64							SAE/HD	Order	SAE/HD	SAE/HD	SAE/HD		
	50				13.01	8.76												SAE/HD	SAE/HD
424	55	6.88	190	15.00	16.14	9.89	6.25	0.98	9.57	1.00	424			SAE/HD	Order	SAE/HD	SAE/HD		
	60				17.14	10.89												SAE/HD	SAE/HD
456	70	8.00	220	18.00	19.69	12.44	7.25	1.32	11.63	1.13	456						SAE/HD	SAE/HD	
	75				20.76	13.51												SAE/HD	SAE/HD
511	80	10.00	280	22.00	23.76	14.76	9.00	1.56	14.5	1.38	511						SAE/HD	SAE/HD	
	85				24.76	15.76													
	92				26.26	17.26													
											<b>SAE Bolting</b>								
											BC	11.625	13.125	17.25	19.25	21.375	25.25	27.25	
											Hole Qty	8	8	8	8	6	12	12	
											Hole Dia	0.41	0.41	0.53	0.53	0.65	0.65	0.78	
											<b>HD Bolting</b>								
											BC	11.5	12.5	16.75	18.5	20.5	24.5	26.875	
											Hole Qty	8	8	8	8	8	12	12	
											Hole Dia	0.53	0.65	0.78	0.91	1.03	1.03	1.03	
											<b>Speed Limit by Adapter O.D. (2b)</b>								
											RPM	3,400	3,400	2,900	2,600	2,400	2,000	1,800	

Size	Spacer	Rated Torque		Peak Overload	Max RPM (2a)	Weight (1)	WR <sup>2</sup> (1)	Misalignment Capacity			
		HP/100 RPM	(lb-in)					(lb-in)	Axial (+/- in)	Angular (Degrees/Disc Pack)	
340	31	64	40,000	60,000	3,400	46	567	0.06	0.33°		
	35									47	572
412	42	190	120,000	180,000	2,500	127	3,267	0.08			
	45									129	3,281
	50									132	3,312
424	55	380	240,000	360,000	1,800	261	8,346	0.10			
	60									268	8,464
456	70	889	560,000	840,000	1,500	491	22,549	0.12			
	75									502	22,825
511	80	1,746	1,100,000	1,650,000	1,200	870	58,863	0.14			
	85								885	59,503	
	92								1014	68,905	

- 1) Weight and WR2 calculated with hub at maximum inch bore size and minimum available adapter size.
- 2) a) Max RPM shown for smallest available adapter size, do not exceed this speed for any given coupling size.  
b) Verify that adapter speed limit is adequate for application speed, do not exceed coupling MAX RPM (See note 2a).
- 3) Flywheel mounting hardware is not supplied with coupling.
- 4) Consult factory for torsional stiffness and alternating torque limits.

### ORDERING

- 1) Specify coupling size and spacer option  
Example: GCF424-60
- 2) Specify adapter size code. Specify bolting pattern for items noted as drilled per order.  
Example: GCF424-60-26 or GCF424-60-22HD
- 3) Specify hub bore size and tolerance, keyway size or keyless, special hub length, etc.

### STANDARD MATERIALS

HUB - CARBON STEEL  
 SPACER - DUCTILE IRON  
 FLYWHEEL ADAPTER - DUCTILE IRON  
 HARDWARE - ALLOY STEEL  
 DISC PACKS - HIGH CARBON STEEL

# Heavy Duty Spacer Coupling HSH Series - Form-Flex®

## Double Flex Spacer

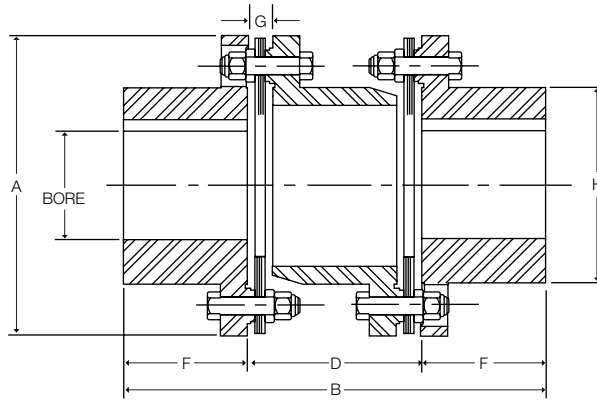

### STANDARD MATERIALS

HUBS - CARBON STEEL  
 SPACER - GREY OR DUCTILE IRON  
 HARDWARE - ALLOY STEEL  
 DISC PACKS - HIGH CARBON STEEL

### MATERIAL / FINISH OPTIONS

DISC PACKS - STAINLESS STEEL  
 ZINC PHOSPHATE COATING  
 ALLOY STEEL HUBS  
 CAST IRON HUBS  
 (Sizes 31-45)

Size	Dimensions (in)									
	Max Bore				A (2)	B	D DBSE	F	G	H
	Iron		Steel							
(in)	(mm)	(in)	(mm)							
22	-	-	2.75	79	5.88	8.02	3.02	2.50	0.43	3.87
26	-	-	3.25	92	6.88	9.25	3.50	2.88	0.55	4.50
31	3.12	82	4.13	113	8.12	10.87	4.12	3.37	0.62	5.50
35	3.62	97	4.50	125	9.12	12.06	4.57	3.75	0.66	6.12
37	3.75	100	4.63	130	10.06	13.12	5.14	4.00	0.81	6.50
42	4.25	114	5.00	142	11.00	13.93	5.43	4.25	0.81	7.00
45	4.50	120	5.50	150	11.87	14.75	5.75	4.50	0.87	7.43
50	-	-	6.13	170	12.90	16.81	6.81	5.00	1.06	8.37
55	-	-	6.88	193	15.00	18.68	7.68	5.50	1.25	9.50
60	-	-	7.50	212	16.00	20.93	8.43	6.25	1.34	10.50
70	-	-	8.50	233	18.50	23.62	9.56	7.00	1.50	11.75
75	-	-	9.00	261	20.00	25.00	10.50	7.25	1.53	13.00
80	-	-	9.12	275	22.00	26.87	11.37	7.75	1.56	13.75
85	-	-	10.38	290	23.75	28.62	12.12	8.25	1.62	14.50
92	-	-	11.00	320	25.75	31.00	13.01	9.00	1.75	15.87
92HT	-	-	10.50	307	25.75	31.00	13.01	9.00	1.75	15.87

Size	HP/ 100 RPM	Rated Torque (lb-in)	Peak O/L Torque (lb-in)	Max RPM	Weight (lbs) (1)	WR <sup>2</sup> (lb-in <sup>2</sup> ) (1)	Misalignment Capacity	
							Axial (+/- in)	Angular (Degrees/ Discpack)
22	15.1	9,500	14,250	3,800	19.7	75.6	0.036	0.33°
26	25.4	16,000	24,000	3,300	28.8	152	0.044	
31	38.1	24,000	36,000	2,800	51.4	390	0.052	
35	69.8	44,000	66,000	2,600	76.7	738	0.056	
37	95.2	60,000	90,000	2,500	92.4	1,090	0.062	
42	116	73,000	109,500	2,400	125	1,710	0.067	
45	157	99,000	148,500	2,250	154	2,510	0.072	
50	203	128,000	192,000	2,000	218	4,570	0.082	
55	300	189,000	283,500	1,800	288	7,400	0.092	
60	414	261,000	391,500	1,600	403	13,100	0.102	
70	659	415,000	622,500	1,400	624	25,800	0.115	
75	846	533,000	799,500	1,300	788	37,900	0.125	
80	1,087	685,000	1,027,500	1,200	1,030	58,700	0.136	
85	1,316	829,000	1,243,500	1,100	1,230	79,000	0.140	
92	1,651	1,040,000	1,560,000	1,000	1,630	129,000	0.156	
92HT	2,221	1,400,000	2,100,000	1,000	1,680	137,000	0.156	

- 1) Weight and WR<sup>2</sup> are calculated with steel hubs at maximum inch bore size.
- 2) Consult factory for torsional stiffness and alternating torque limits.

### ORDERING

HSH SERIES COUPLINGS ARE SOLD AS COMPLETE ASSEMBLIES (Components and repair kits are available for repairs)

- 1) Specify coupling
- 2) Specify hub bore size and tolerance, keyway size or specify for each hub.
- 3) Specify disc pack material

# Heavy Duty Spacer Coupling FSH Series - Form-Flex®

## Double Flex Spacer

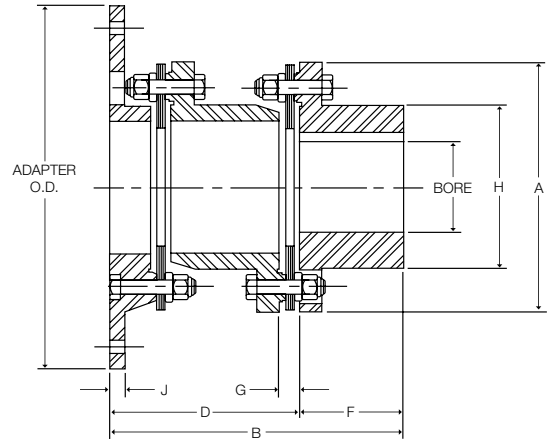

**Adapter O.D. / Standard Bolt Pattern**

	12.375	13.875	18.375	20.375	22.500	26.500	28.875
	12	14	18	20	22	26	28
<b>SAE Bolting</b>							
BC	11.625	13.125	17.25	19.25	21.375	25.25	27.25
Hole Qty	8	8	8	8	6	12	12
Hole Dia	0.41	0.41	0.53	0.53	0.65	0.65	0.78
<b>HD Bolting</b>							
BC	11.50	12.50	16.75	18.50	20.50	24.50	26.875
Hole Qty	8	8	8	8	8	12	12
Hole Dia	0.53	0.65	0.78	0.91	1.03	1.03	1.03

### STANDARD MATERIALS

HUBS - CARBON STEEL  
 SPACER - DUCTILE IRON OR CAST IRON  
 FLYWHEEL ADAPTER - DUCTILE IRON OR CAST IRON  
 HARDWARE - ALLOY STEEL  
 DISC PACKS - HIGH CARBON STEEL

Size	Max Bore				Dimensions (in)							Available Adapter Sizes							
	Iron		Steel		A	B	D DBSE	F	G	H	J	X = Stock Size 0 = MTO							
	(in)	(mm)	(in)	(mm)								10	12	14	18	20	22	26	28
31	3.12	82	4.13	113	8.12	8.68	5.31	3.37	0.62	5.50	0.50	0	0	X	X	0	0		
35	3.62	97	4.50	125	9.12	9.62	5.87	3.75	0.66	6.12	0.50	0	0	X	X	0	0		
37	3.75	100	4.63	130	10.06	10.62	6.62	4.00	0.81	6.50	0.56			0	0	0	0		
42	4.25	114	5.00	142	11.00	11.37	7.12	4.25	0.81	7.00	0.63			0	X	0	X	X	0
45	4.50	120	5.50	150	11.87	12.00	7.50	4.50	0.87	7.43	0.69			0	X	0	X	X	0
50	-	-	6.13	170	12.90	13.75	8.75	5.00	1.06	8.37	0.75				X	0	X	X	X
55	-	-	6.88	193	15.00	15.31	9.81	5.50	1.25	9.50	0.88				X	0	X	X	X
60	-	-	7.50	212	16.00	17.12	10.87	6.25	1.34	10.50	1.00				X	0	X	X	X
70	-	-	8.50	233	18.50	19.43	12.43	7.00	1.50	11.75	1.00					X	X	X	X
75	-	-	9.00	261	20.00	20.75	13.50	7.25	1.53	13.00	1.13					0	0	X	X
80	-	-	9.12	275	22.00	22.50	14.75	7.75	1.56	13.75	1.25							0	X
85	-	-	10.38	290	23.75	24.00	15.75	8.25	1.62	14.50	1.25								X
92	-	-	11.00	320	25.75	26.25	17.27	9.00	1.75	15.87	1.38								X
92HT	-	-	10.50	307	25.75	26.25	17.26	9.00	1.75	15.87	1.38								X

Size	HP/ 100 RPM	Rated Torque (lb-in)	Peak O/L Torque (lb-in)	Max RPM (2)	Weight (lbs) (1)	WR <sup>2</sup> (lb-in <sup>2</sup> ) (1)	Misalignment Capacity	
							Axial +/- in	Angular (Degrees/ Disc Pack)
31	38.1	24,000	36,000	2,800	41	399	0.052	0.33°
35	69.8	44,000	66,000	2,600	59	643	0.056	
37	95.2	60,000	90,000	2,500	82	1,280	0.062	
42	116	73,000	109,500	2,400	107	1,770	0.067	
45	157	99,000	148,500	2,250	127	2,370	0.072	
50	203	128,000	192,000	2,000	189	5,320	0.082	
55	300	189,000	283,500	1,800	241	7,590	0.092	
60	414	261,000	391,500	1,600	325	11,800	0.102	
70	659	415,000	622,500	1,400	523	25,000	0.115	
75	846	533,000	799,500	1,300	675	35,000	0.125	
80	1,087	685,000	1,027,500	1,200	905	58,400	0.136	
85	1,316	829,000	1,243,500	1,100	1060	79,400	0.140	
92	1,651	1,040,000	1,560,000	1,000	1,400	120,000	0.156	
92HT	2,221	1,400,000	2,100,000	1,000	1,450	129,000	0.156	

- 1) Weight and WR<sup>2</sup> calculated with steel hubs at maximum inch bore size and minimum available adapter size.
- 2) a) Max RPM shown for smallest available adapter size, do not exceed this speed for any given coupling size.  
 b) Verify that adapter speed limit is adequate for application speed, do not exceed coupling MAX RPM (See note 2a).
- 3) Flywheel mounting hardware is not supplied with coupling.
- 4) Consult factory for torsional stiffness and alternating torque limits.

### ORDERING

FSH SERIES COUPLINGS ARE SOLD AS COMPLETE ASSEMBLIES (Components and repair kits are for repairs)

- 1) Specify coupling size and adapter size
- 2) Specify hub bore size and tolerance, keyway keyless, special hub length, etc.
- 3) Specify disc pack material



# Coupling Repair Parts and Kits

Notes:

- 1) Single Repair Kits include 1 disc pack and all bolts, nuts and washers for use with 1 disc pack
- 2) Single hardware Kits include all bolts, nuts and washers for use with 1 disc pack
- 3) Double Repair Kits include 2 disc packs and all hardware for one coupling
- 4) Double hardware kits include all bolt, nuts and washers for one coupling

## Form-Flex® (A Series)

Kit Type	Repair		Hardware		Repair	Hdwr	Repair	Hdwr	Disc Pack	Rough Bore Hub					
	Single									Double		Double		AJ (Std)	
SGL/DBL															
Used On	AA, AP, AR, A5, A6, A7				AX		AY		All	All	All	All	All	All	All
Mat'l Class	A,B	C,E	A,B	C,E	A,B	A,B	A,B	A,B	All	A	B,C	E	A	B,C	E
5	A05RKA	***	A05HKA	***	AX05RKA	AX05HKA	AY05RKA	AY05HKA	A005-4101	AJ05RBA	AJ05RBB	***	AZ05RBA	AZ05RBB	***
10	A10RKA	***	A10HKA	***	AX10RKA	AX10HKA	AY10RKA	AY10HKA	A010-4101	AJ10RBA	AJ10RBB	***	AZ10RBA	AZ10RBB	***
15	A15RKA	A15RKE	A15HKA	A15HKE	AX15RKA	AX15HKA	AY15RKA	AY15HKA	A015-4101	AJ15RBA	AJ15RBB	AJ15RBE	AZ15RBA	AZ15RBB	AZ15RBE
20	A20RKA	A20RKE	A20HKA	A20HKE	AX20RKA	AX20HKA	AY20RKA	AY20HKA	A020-4101	AJ20RBA	AJ20RBB	AJ20RBE	AZ20RBA	AZ20RBB	AZ20RBE
25	A25RKA	A25RKE	A25HKA	A25HKE	AX25RKA	AX25HKA	AY25RKA	AY25HKA	A025-4101	AJ25RBA	AJ25RBB	AJ25RBE	AZ25RBA	AZ25RBB	AZ25RBE
30	A30RKA	A30RKE	A30HKA	A30HKE	AX30RKA	AX30HKA	***	***	A030-4101	AJ30RBA	AJ30RBB	AJ30RBE	AZ30RBA	AZ30RBB	AZ30RBE
35	A35RKA	A35RKE	A35HKA	A35HKE	AX35RKA	AX35HKA	***	***	A035-4101	AJ35RBA	AJ35RBB	AJ35RBE	AZ35RBA	AZ35RBB	AZ35RBE

## Form-Flex® (A5C/B5C Series)

Kit Type	Repair			Hardware			Repair			Hardware			Disc Pack
	Single						Double						
SGL/DBL													
Used On	A5C, B5C						A5C, B5C						All
Mat'l Class	A,B	C	E	A,B	C	E	A,B	C	E	A,B	C	E	ALL
15	A5C15RKA	A5C15RKE	A5C15HKA	A5C15HKE	A5C15RKA-DF	A5C15RKE-DF	A5C15RKA-DF	A5C15RKE-DF	A5C15HKA-DF	A5C15HKE-DF	A5C15HKA-DF	A5C15HKE-DF	A015-4101
20	A5C20RKA	A5C20RKE	A5C20HKA	A5C20HKE	A5C20RKA-DF	A5C20RKE-DF	A5C20RKA-DF	A5C20RKE-DF	A5C20HKA-DF	A5C20HKE-DF	A5C20HKA-DF	A5C20HKE-DF	A020-4101
25	A5C25RKA	A5C25RKE	A5C25HKA	A5C25HKE	A5C25RKA-DF	A5C25RKE-DF	A5C25RKA-DF	A5C25RKE-DF	A5C25HKA-DF	A5C25HKE-DF	A5C25HKA-DF	A5C25HKE-DF	A025-4101
30	A5C30RKA	A5C30RKE	A5C30HKA	A5C30HKE	A5C30RKA-DF	A5C30RKE-DF	A5C30RKA-DF	A5C30RKE-DF	A5C30HKA-DF	A5C30HKE-DF	A5C30HKA-DF	A5C30HKE-DF	A030-4101
35	A5C35RKA	A5C35RKE	A5C35HKA	A5C35HKE	A5C35RKA-DF	A5C35RKE-DF	A5C35RKA-DF	A5C35RKE-DF	A5C35HKA-DF	A5C35HKE-DF	A5C35HKA-DF	A5C35HKE-DF	A035-4101
58	B5C58RKA	B5C58RKE	B5C58HKA	B5C58HKE	B5C58RKA-DF	B5C58RKE-DF	B5C58RKA-DF	B5C58RKE-DF	B5C58HKA-DF	B5C58HKE-DF	B5C58HKA-DF	B5C58HKE-DF	B058-4101

## Torsiflex-i (TF Series)

Kit Type	Repair Kit (4)	Hardware Kit (1)	Disc Pack (2)	TF Hub Attachment Screw Kit (3)	TFI Hub Attachment Screw Kit (3)	Rough Bore Hub	
						Std	Overize
Cplg Size			300 Series S.S				
0017	TF0017EK	TF0017HK	TF0017-5-SS	TF0017HAS	TFI0017HAS	TFI0027AH	TFI0017LAH
0027	TF0027EK	TF0027HK	TF0027-5-SS	TF0027HAS	TFI0027HAS	TFI0027AH	TFI0027LAH
0038	TF0038EK	TF0038HK	TF0038-5-SS	TF0038HAS	TFI0038HAS	TFI0038AH	TFI0038LAH
0140	TF0140EK	TF0140HK	TF0140-5-SS	TF0140HAS	TFI0140HAS	TFI0140AH	-
0260	TF0260EK	TF0260HK	TF0260-5-SS	TF0260HAS	TFI0260HAS	TFI0260AH	-
0400	TF0400EK	TF0400HK	TF0400-5-SS	TF0400HAS	TFI0400HAS	TFI0400AH	-
0750	TF0750EK	TF0750HK	TF0750-5-SS	TF0750HAS	TFI0750HAS	TFI0750AH	-
1310	TF1310EK	TF1310HK	TF1310-5-SS	TF1310HAS	TFI1310HAS	TFI1310AH	-
1900	TF1900EK	TF1900HK	TF1900-5-SS	TF1900HAS	TFI1900HAS	TFI1900AH	-
2500	TF2500EK	TF2500HK	TF2500-5-SS	TF2500HAS	TFI2500HAS	TFI2500AH	-
3300	TF3300EK	TF3300HK	TF3300-5-SS	TF3300HAS	TFI3300HAS	TFI3300AH	-
6000	TF6000EK	TF6000HK	TF6000-5-SS	TF6000HAS	TFI6000HAS	TFI6000AH	-
8500	TF8500EK	TF8500HK	TF8500-5-SS	TF8500HAS	TFI8500HAS	TFI8500AH	-
12000	TF12000EK	TF12000HK	TF12000-5-SS	TF12000HAS	TFI12000HAS	TFI12000AH	-

- 1) Contains bolts, nuts and washers for 1 disc pack, 2 required for a complete coupling
- 2) Includes 1 complete disc pack, 2 required for a complete coupling
- 3) Contains all fasteners for 1 hub, 2 required for a complete coupling
- 4) Repair Kits include 1 disc pack and all disc pack bolts, nuts and washers for one end of a coupling, 2 kits required for a complete coupling.

# Coupling Repair Parts and Kits (Cont.)

## Form-Flex® (G Series)

Kit Type	Repair Kits				Hardware Kit	Disc Pack		Rough Bore Hub	
Used On	Double		Single		Single (1)	SS	CS	Std	Oversize
Mat'l Class	Disc Pack SS	Disc Pack CS	Disc Pack SS	Disc Pack CS					
311	G311-DF-SS	-	G311-SF-SS	-	G311-HK	G311-5-SS	-	G311-3ST	G311-3LST
321	G321-DF-SS	-	G321-SF-SS	-	G321-HK	G321-5-SS	-	G321-3ST	G321-3LST
332	G332-DF-SS	-	G332-SF-SS	-	G332-HK	G332-5-SS	-	G332-3ST	G332-3LST
346	G346-DF-SS	-	G346-SF-SS	-	G346-HK	G346-5-SS	-	G346-3ST	G346-3LST
380	G380-DF-SS	-	G380-SF-SS	-	G380-HK	G380-5-SS	-	G380-3ST	G380-3LST
412	G412-DF-SS	G412-DF	G412-SF-SS	G412-SF	G412-HK	G412-5-SS	G412-5	G412-3ST	G412-3LST
419	G419-DF-SS	G419-DF	G419-SF-SS	G419-SF	G419-HK	G419-5-SS	G419-5	G419-3ST	G419-3LST
424	G424-DF-SS	G424-DF	G424-SF-SS	G424-SF	G424-HK	G424-5-SS	G424-5	G424-3ST	-
444	G444-DF-SS	G444-DF	G444-SF-SS	G444-SF	G444-HK	G444-5-SS	G444-5	G444-3ST	-
456	G456-DF-SS	G456-DF	G456-SF-SS	G456-SF	G456-HK	G456-5-SS	G456-5	G456-3ST	-
483	G483-DF-SS	G483-DF	G483-SF-SS	G483-SF	G483-HK	G483-5-SS	G483-5	G483-3ST	-
511	G511-DF-SS	G511-DF	G511-SF-SS	G511-SF	G511-HK	G511-5-SS	G511-5	G511-3ST	-
520	G520-DF-SS	G520-DF	G520-SF-SS	G520-SF	G520-HK	G520-5-SS	G520-5	G520-3ST	-
525	G525-DF-SS	G525-DF	G525-SF-SS	G525-SF	G525-HK	G525-5-SS	G525-5	G525-3ST	-
530	G530-DF-SS	G530-DF	G530-SF-SS	G530-SF	G530-HK	G530-5-SS	G530-5	G530-3ST	-
540	G540-DF-SS	G540-DF	G540-SF-SS	G540-SF	G540-HK	G540-5-SS	G540-5	G540-3ST	-

## Form-Flex® (HSH/FSH Series)

Kit Type	Repair Kits				Hardware Kit	Disc Pack		Rough Bore Hub	
Cplg Size	Double		Single (1)		Single (2)	SS	CS	STL	Cast Iron
	Disc Pack SS	Disc Pack CS	Disc Pack SS	Disc Pack CS					
22	D22-DF-SS	D22-DF	D22-SF-SS	D22-SF	D22-BNW	D22-5-SS	D22-5	D22-3ST	-
26	D26-DF-SS	D26-DF	D26-SF-SS	D26-SF	D26-BNW	D26-5-SS	D26-5	D26-3ST	-
31	D31-DF-SS	D31-DF	D31-SF-SS	D31-SF	D31-BNW	D31-5-SS	D31-5	D31-3ST	D31-3
35	D35-DF-SS	D35-DF	D35-SF-SS	D35-SF	D35-BNW	D35-5-SS	D35-5	D35-3ST	D35-3
37	D37-DF-SS	D37-DF	D37-SF-SS	D37-SF	D37-BNW	D37-5-SS	D37-5	D37-3ST	D37-3
42	D42-DF-SS	D42-DF	D42-SF-SS	D42-SF	D42-BNW	D42-5-SS	D42-5	D42-3ST	D42-3
45	D45-DF-SS	D45-DF	D45-SF-SS	D45-SF	D45-BNW	D45-5-SS	D45-5	D45-3ST	D45-3
50	D50-DF-SS	D50-DF	D50-SF-SS	D50-SF	D50-BNW	D50-5-SS	D50-5	D50-3ST	-
55	D55-DF-SS	D55-DF	D55-SF-SS	D55-SF	D55-BNW	D55-5-SS	D55-5	D55-3ST	-
60	D60-DF-SS	D60-DF	D60-SF-SS	D60-SF	D60-BNW	D60-5-SS	D60-5	D60-3ST	-
70	D70-DF-SS	D70-DF	D70-SF-SS	D70-SF	D70-BNW	D70-5-SS	D70-5	D70-3ST	-
75	D75-DF-SS	D75-DF	D75-SF-SS	D75-SF	D75-BNW	D75-5-SS	D75-5	D75-3ST	-
80	D80-DF-SS	D80-DF	D80-SF-SS	D80-SF	D80-BNW	D80-5-SS	D80-5	D80-3ST	-
85	D85-DF-SS	D85-DF	D85-SF-SS	D85-SF	D85-BNW	D85-5-SS	D85-5	D85-3ST	-
92	D92-DF-SS	D92-DF	D92-SF-SS	D92-SF	D92-BNW	D92-5-SS	D92-5	D92-3ST	-
92HT	D92HT-DF-SS	D92HT-DF	D92HT-SF-SS	D92HT-SF	D92HT-BNW	D92-5-SS	D92-5	D92HT-3ST	-

## Form-Flex® (GCH/GCF Series)

Kit Type	Repair Kits				Hardware Kit	Disc Pack		Rough Bore Hub
Cplg Size	Double		Single (1)		Single (2)	SS	CS	STL
	Disc Pack SS	Disc Pack CS	Disc Pack SS	Disc Pack CS				
340	G340-DF-SS	G340-DF	G340-SF-SS	G340-SF	G340-BN	G340-5-SS	G340-5	G340-3ST
412	G412-DF-SS	G412-DF	G412-SF-SS	G412-SF	G412-BN	G412-5-SS	G412-5	G412-3ST
424	G424-DF-SS	G424-DF	G424-SF-SS	G424-SF	G424-BN	G424-5-SS	G424-5	G424-3ST
456	G456-DF-SS	G456-DF	G456-SF-SS	G456-SF	G456-BN	G456-5-SS	G456-5	G456-3ST
511	G511-DF-SS	G511-DF	G511-SF-SS	G511-SF	G511-BN	G511-5-SS	G511-5	G511-3ST



# Form-Flex® A-Series Hub Options

TO ORDER A COMPLETE COUPLING, ORDER TWO HUBS OF ANY TYPE AND A COUPLING (SPACER) SUB ASSEMBLY FOR THE REQUIRED COUPLING TYPE. ALL DIMENSIONS SHOWN IN INCHES.

## AJ STANDARD HUBS - PROVIDED WITH STRAIGHT BORE AND KEYWAY - SOLID HUBS AVAILABLE FROM STOCK

Size	Max Bore		A	B	F	H	J	Std Set Screw Size
	(in)	(mm)						
05	0.875	22	2.65	0.25	1.00	1.30	0.38	#10-24 UNC
10	1.250	33	3.19	0.30	1.00	1.80	0.38	1/4-20 UNC
15	1.375	36	3.65	0.35	1.13	2.00	0.41	1/4-20 UNC
20	1.688	46	4.08	0.35	1.32	2.40	0.50	1/4-20 UNC
25	2.000	53	4.95	0.45	1.62	2.80	0.63	5/16-18 UNC
30	2.380	63	5.63	0.55	1.88	3.30	0.69	5/16-18 UNC
35	2.938	80	6.63	0.55	2.25	4.15	0.88	1/2-13 UNC

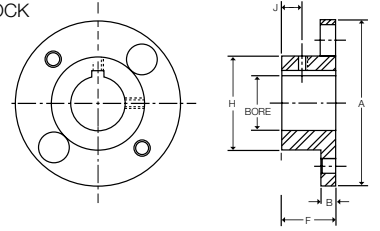

## AZ OVERSIZE BORE HUBS - PROVIDED WITH STRAIGHT BORE AND KEYWAY

Size	Max Bore		A	B	F	H	J	Std Set Screw Size
	(in)	(mm)						
05	1.188	30	2.65	0.25	1.00	1.88	0.38	#10-24 UNC
10	1.625	43	3.19	0.30	1.00	2.37	0.38	1/4-20 UNC
15	1.750	48	3.65	0.35	1.13	2.69	0.41	1/4-20 UNC
20	2.125	58	4.08	0.35	1.32	3.13	0.50	1/4-20 UNC
25	2.563	68	4.95	0.45	1.62	3.75	0.63	5/16-18 UNC
30	2.875	79	5.63	0.55	1.88	4.25	0.69	5/16-18 UNC
35	3.750	101	6.63	0.55	2.25	5.25	0.88	1/2-13 UNC

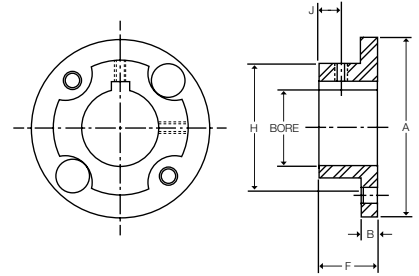

## QD BORED HUBS - MATERIAL CLASS A OR B ONLY

Size	Bush Size	Bush TQ. (lb-in)	Max Bore		B	C	F	H	Bolt Size
			(in)	(mm)					
15	JA	1000	1.250	28	1.17	1.00	0.56	2.00	#10-24 UNC
20	JA	1000	1.250	28	1.17	1.00	0.56	2.40	#10-24 UNC
25	SH	3500	1.688	35	1.50	1.25	0.75	2.80	1/4-20 UNC
30	SD	5000	2.000	42	2.06	1.81	1.25	3.30	1/4-20 UNC
35	SK	7000	2.625	55	2.19	1.87	1.25	4.15	5/16-18 UNC
40	SF	11000	2.938	65	2.38	2.06	1.37	4.65	3/8-16 UNC

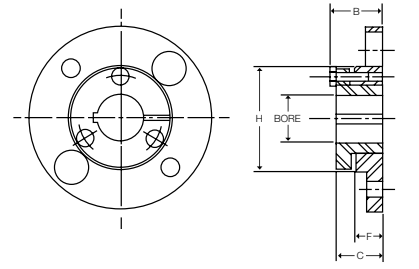

## HUBS FOR TAPER LOCK BUSHINGS - AVAILABLE MTO ONLY

Size	Regular Mount					Reverse Mount				
	Bush Size	Bush TQ. (lb-in)	Max Bore		F (in)	Bush Size	Bush TQ. (lb-in)	Max Bore		F (in)
			(in)	(mm)				(in)	(mm)	
15	N/A	-	-	-	-	1108	1300	1.12	25	0.87
20	1108	1300	1.12	25	0.87	1215	3550	1.25	32	1.50
25	1215	3550	1.25	32	1.50	1310	3850	1.37	35	1.00
30	1310	3850	1.37	35	1.00	1615	4300	1.62	42	1.50
35	2012	7150	2.00	48	1.25	2517	11600	2.50	65	1.75
40	2525	11300	2.50	65	2.50	2525	11300	2.50	65	2.50

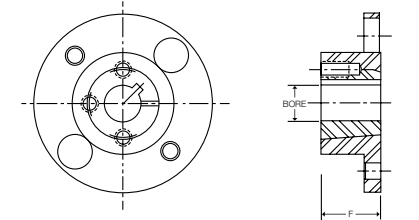

## AC/AD CLAMPING HUBS - AC HUBS PROVIDED WITHOUT KEYWAY - AD HUBS PROVIDED WITH KEYWAY - MATERIAL CLASS A OR B ONLY

Size	Max Bore				A	F	G	H	Clamp Screw Size
	AC		AD						
	(in)	(mm)	(in)	(mm)					
5	1.00	25	0.87	20	2.65	1.13	0.50	2.06	1/4-20 UNC
10	1.00	25	0.87	20	3.19	1.18	0.50	2.06	1/4-20 UNC
	1.50	38	1.25	30		1.36	0.69	2.75	5/16-18 UNC
15	1.00	25	0.87	20	3.65	1.27	0.50	2.06	1/4-20 UNC
	1.75	44	1.37	24		1.46	0.69	3.00	5/16-18 UNC
20	1.31	33	1.00	24	4.08	1.32	0.55	2.38	1/4-20 UNC
	2.13	53	1.62	42		1.52	0.75	3.50	3/8-16 UNC
25	2.13	53	1.62	42	4.95	1.62	0.64	3.50	5/16-18 UNC
	2.50	63	1.87	50		1.86	0.88	4.00	3/8-16 UNC

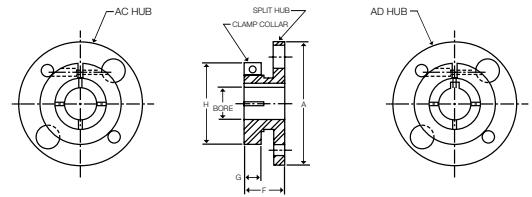

## AL LOCK ELEMENT HUBS - THESE HUBS USE RINGFEDER TAPERED LOCKING ELEMENTS - MATERIAL CLASS A OR B ONLY

Size	Hub Type	Bore Size				B	F	G	Screw Size
		Min		Max					
		(in)	(mm)	(in)	(mm)				
5	AJ	0.24	6	0.51	13	1.00	1.32	0.32	#10-32 UNF
	AZ	0.55	14	0.75	19	1.00	1.42	0.42	1/4-28 UNF
10	AJ	0.47	12	0.71	18	1.00	1.42	0.42	1/4-28 UNF
	AZ	0.75	19	1.18	30	1.00	1.42	0.42	1/4-28 UNF
15	AJ	0.47	12	0.87	22	1.13	1.55	0.42	1/4-28 UNF
	AZ	0.94	24	1.38	35	1.13	1.55	0.42	1/4-28 UNF
20	AJ	0.87	22	1.18	30	1.32	1.78	0.42	1/4-28 UNF
	AZ	1.26	32	1.65	42	1.32	1.83	0.51	5/16-24 UNF
25	AJ	0.87	22	1.26	32	1.63	2.05	0.42	1/4-28 UNF
	AZ	1.38	35	1.97	50	1.63	2.23	0.60	3/8-24 UNF

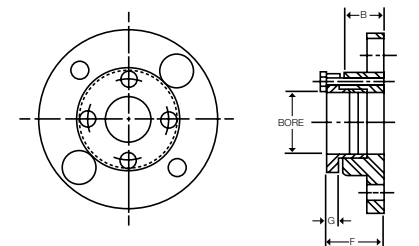

NOTE: AC and AL Hubs do not carry full torque capacity. Please consult engineering.

# Form-Flex® G-Series and Torsiflex-i Hub Options

## CLAMP HUB

PROVIDED WITH STRAIGHT BORE AND KEYWAY

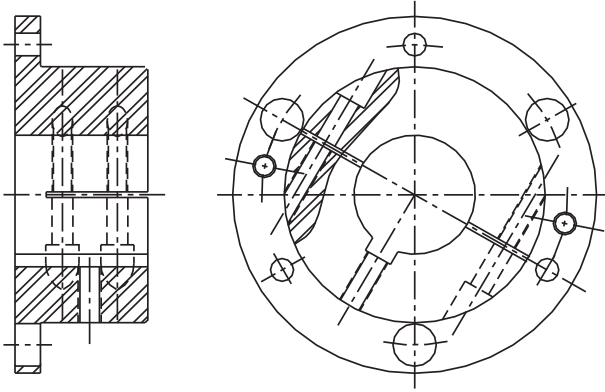

## EXTERNAL LOCKING ELEMENT

USED WITH KEYLESS SHAFTS

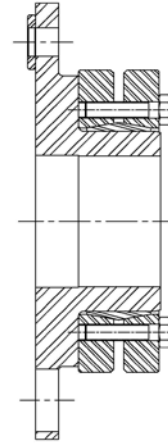

## INTERNAL LOCKING ELEMENT

USED WITH KEYLESS SHAFTS

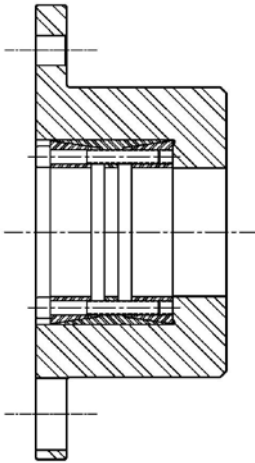

## TAPER BORE WITH HYDRAULIC REMOVAL

USED WITH KEYLESS TAPERED SHAFTS

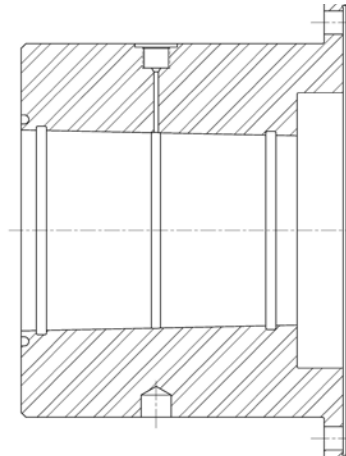

## SPECIAL FLANGE ADAPTERS

DESIGNED TO MATE WITH ANY CUSTOM FLANGE

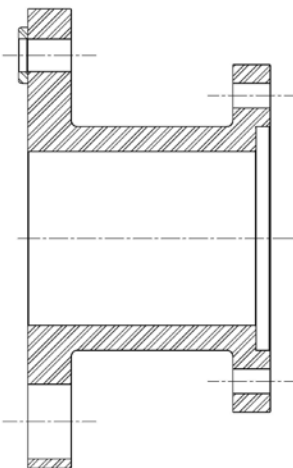

## OVERSIZE HUB DESIGN

FOR INCREASED BORE CAPACITY

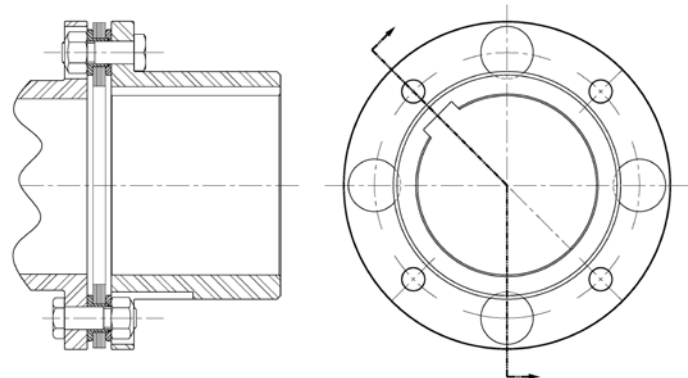

# Coupling Design Options and Special Applications

## ELECTRICAL INSULATION SPACER WITH SPLINE BORE AND EXTERNAL LOCKING ELEMENT

Two piece spacer design with e-glass composite tube separating the steel halves.

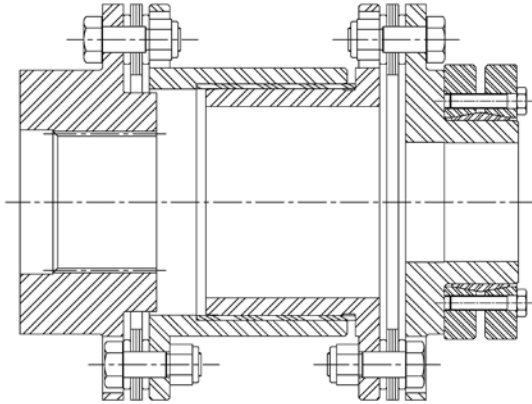

## INERTIA RING ADDED TO TORSIONALLY TUNE COMPRESSOR SYSTEM

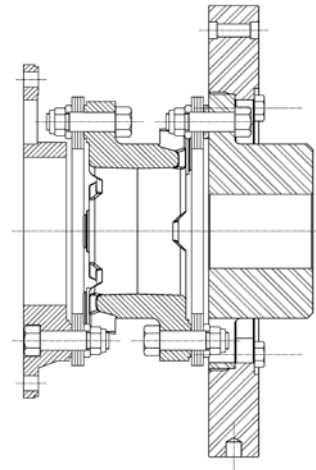

## MODIFIED TORSIFLEX-i DESIGN WITH FLANGE TO FLANGE MOUNTING

Flanges designed to bolt to customer pilot and bolt pattern for test stand application.

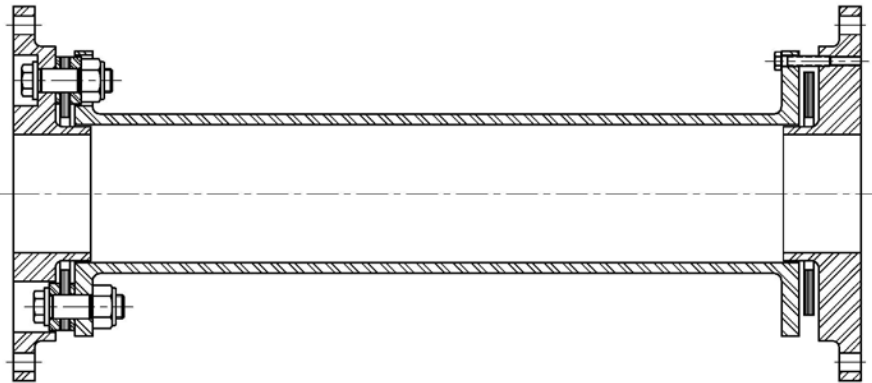

## FLOATING SHAFT COUPLING WITH OVER SIZED TUBE FOR INCREASED STIFFNESS AND CRITICAL SPEED WITH CUSTOM FLANGE ADAPTER

Special features include oversize steel tube welded to bolted adapters for easy assembly, motor hub with integral brake disc, custom flange.

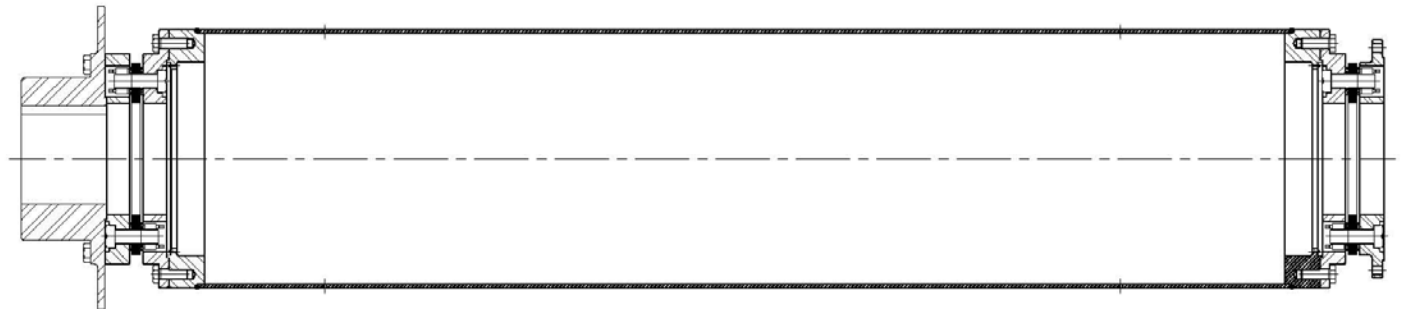

# Coupling Design Options and Special Applications

## MULTI-SHAFT ASSEMBLY FOR VERICAL PUMPING STATIONS USING COMPOSITE TUBE TECHNOLOGY

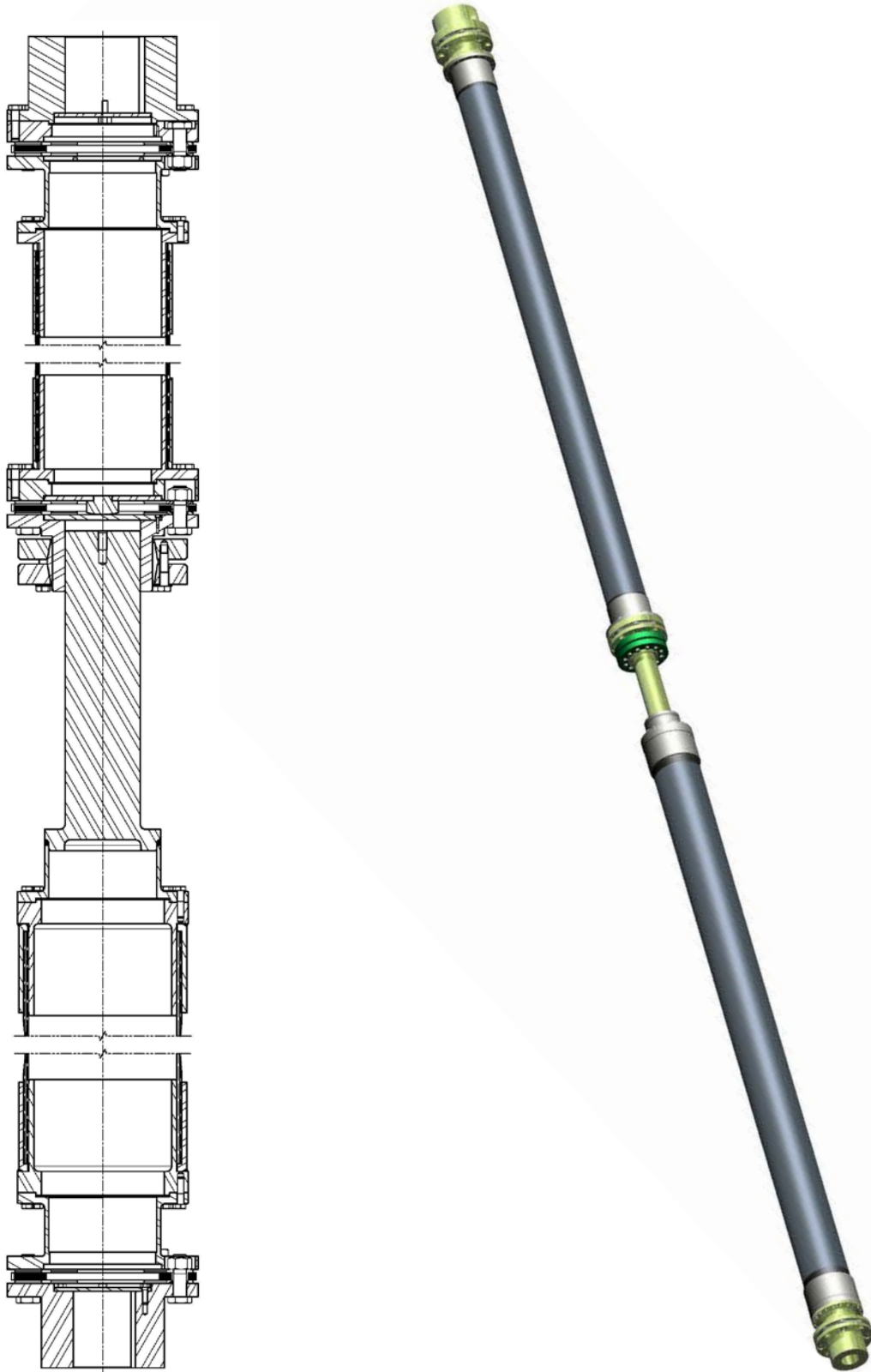

# Disc, Bolt Thread and Tool Size Identification Chart

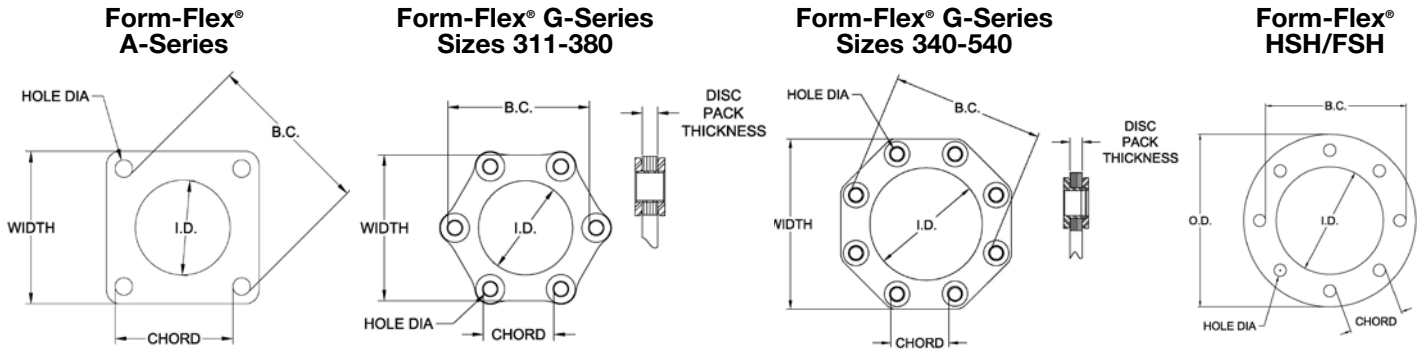

Coupling Series	Disc Size	Disc Dimensions (in)						Bolt				Nut	
		Width/OD	ID	Hole Dia.	B.C. Dia.	Chord	Disc Pack Thickness	Thread Dia. (in)	Thread Pitch	Thread Designation	HEX WAF (in)	HEX WAF (in)	Wrench Torque (lb-ft)
Form-Flex A-Series	5	1.83	1.00	0.25	1.88	1.31	0.06	0.250	28	1/4-28	0.438	0.438	8
	10	2.19	1.17	0.25	2.37	1.69	0.09	0.250	28	1/4-28	0.438	0.438	8
	15	2.54	1.28	0.31	2.69	1.88	0.12	0.313	24	5/16-24	0.500	0.500	17
	20	2.84	1.65	0.31	3.12	2.19	0.14	0.313	24	5/16-24	0.500	0.500	17
	25	3.52	1.78	0.44	3.75	2.63	0.15	0.438	20	7/16-20	0.625	0.625	40
	30	4.01	2.01	0.50	4.25	3.00	0.21	0.500	20	1/2-20	0.750	0.750	58
Form-Flex G-Series	35	4.71	2.71	0.50	5.25	3.69	0.27	0.500	20	1/2-20	0.750	0.750	58
	311	4.78	3.58	0.39	4.86	2.44	0.20	0.313	24	5/16-24	0.500	0.500	22
	321	5.38	3.72	0.51	5.25	2.63	0.25	0.438	20	7/16-20	0.625	0.688	55
	332	6.00	3.87	0.64	5.81	2.88	0.32	0.563	18	9/16-18	0.813	0.813	120
	346	6.93	4.75	0.64	6.81	3.38	0.32	0.563	18	9/16-18	0.813	0.813	120
	380	8.05	5.06	0.87	7.48	3.75	0.39	0.750	16	3/4-16	1.125	1.125	288
	340	7.50	4.91	0.63	6.75	2.56	0.24	0.500	20	1/2-20	0.875	0.875	75
	412	9.61	6.10	1.00	8.50	3.25	0.39	0.750	16	3/4-16	1.250	1.250	250
	419	11.01	7.00	1.14	9.75	3.75	0.50	1.000	14	1-14	1.625	1.625	450
	424	13.49	8.89	1.20	12.01	4.63	0.50	1.000	14	1-14	1.625	1.625	450
	444	15.06	9.60	1.44	13.19	5.06	0.57	1.125	12	1 1/8-12	1.813	1.813	650
	456	16.57	10.66	1.56	14.57	5.56	0.69	1.250	12	1 1/4-12	2.000	2.000	830
	483	17.90	11.54	1.67	15.75	6.00	0.77	1.375	12	1 3/8-12	2.188	2.188	1,000
	511	20.35	13.50	1.74	18.06	6.94	0.93	1.500	12	1 1/2-12	2.375	2.364	1,400
520	23.19	14.59	2.21	20.20	7.75	1.14	1.875	12	1 7/8-12	3.000	0.438	108	
525	24.95	15.64	2.35	21.70	8.31	1.20	2.000	12	2-12	3.125	0.438	124	
530	26.12	16.34	2.50	22.70	8.69	1.26	2.125	12	2 1/8-12	3.375	0.438	141	
540	31.21	21.15	2.65	28.05	10.75	1.58	2.250	10	2 1/4-12	3.750	0.563	196	
Form-Flex HSH/FSH	22	5.625	3.855	0.3275	4.7505	1.81	0.18	0.313	24	5/16-24	0.500	0.500	25
	26	6.565	4.400	0.4055	5.5010	2.13	0.22	0.375	24	3/8-24	0.563	0.563	30
	31	7.750	5.250	0.4680	6.5000	2.50	0.25	0.438	20	7/16-20	0.625	0.625	40
	35	8.625	5.750	0.5315	7.2500	2.75	0.29	0.500	20	1/2-20	0.813	0.750	70
	37	9.625	6.312	0.6265	8.0000	3.06	0.33	0.563	18	9/16-18	0.938	0.875	95
	42	10.500	6.750	0.6885	8.6250	3.31	0.31	0.625	18	5/8-18	1.063	0.938	125
	45	11.250	7.250	0.7505	9.2500	3.56	0.38	0.625	18	5/8-18	1.125	1.063	150
	50	12.813	8.500	0.8755	10.5000	4.00	0.47	0.750	16	3/4-16	1.250	1.250	210
	55	14.375	9.000	1.0005	11.7500	4.50	0.54	0.875	14	7/8-14	1.375	1.438	320
	60	15.938	9.938	1.1270	13.0000	5.00	0.59	1.000	14	1-1/4	1.625	1.625	450
	70	18.125	11.125	1.3120	14.7500	5.63	0.78	1.125	12	1 1/8-12	1.750	1.813	575
	75	19.720	12.000	1.4380	16.0000	6.13	0.80	1.250	12	1 1/4-12	1.938	2.000	830
	80	21.438	13.125	1.5630	17.3760	6.63	0.81	1.375	12	1 3/8-12	2.125	2.188	1000
	85	22.875	14.000	1.7505	18.5000	7.06	0.88	1.500	12	1 1/2-12	2.500	2.375	1400
	92	24.875	15.000	1.8760	20.0000	7.63	1.01	1.500	12	1 1/2-12	2.500	2.375	1400
	92HT	24.875	15.000	1.8760	20.0000	7.63	1.01	1.750	12	1 3/4-12	2.500	2.750	2400

# Application Data Sheet

Project Ref: \_\_\_\_\_  
 Company: \_\_\_\_\_ Date: \_\_\_\_\_  
 Contact: \_\_\_\_\_ Email: \_\_\_\_\_  
 Replacing: \_\_\_\_\_ Phone #: \_\_\_\_\_

<b>SECTION I - DRIVER</b>	Electric Motor <input type="checkbox"/> ; Engine <input type="checkbox"/> - # Cylinders _____ ; Turbine <input type="checkbox"/> ; Other _____
HP: _____ KW: _____	Normal Torque: _____ Lb-in[ ] Nm[ ]
Rated Speed: _____	Max Torque: _____ Lb-in[ ] Nm[ ]
Operating Speed: _____	Breakdown Torque: _____ Lb-in[ ] Nm[ ]

<b>SECTION II - DRIVEN</b>	Description: _____
Load Application: Non-Pulsating <input type="checkbox"/> Medium Pulsating <input type="checkbox"/> Heavy Pulsating <input type="checkbox"/> Smooth <input type="checkbox"/> Light Shock <input type="checkbox"/> Heavy Shock <input type="checkbox"/>	

<b>SECTION III - COUPLING APPLICATION</b>	Min Service Factor: _____
Temperature Range: _____ to _____ °C <input type="checkbox"/> or °F <input type="checkbox"/>	Hydraulic Removal: Yes <input type="checkbox"/> No <input type="checkbox"/>
Specification: API671 <input type="checkbox"/> Edition _____ ; API610 <input type="checkbox"/> Edition _____ ; Other _____	
Balance: Cplg <input type="checkbox"/> Hubs <input type="checkbox"/> Spacer <input type="checkbox"/>	Balance Specification _____

<b>SECTION IV - DIMENSIONAL DATA</b>	Distance Between Shaft Ends (DBSE): _____ IN <input type="checkbox"/> MM <input type="checkbox"/>
Taper Shaft & Keyway Data	
Driver	Driven
Shaft Dia (Straight): _____	_____
Shaft Dia L.E. (Taper): _____	_____
Taper Ratio _____	_____
Keyway Size: Width _____ Depth _____	Width _____ Depth _____
KW Depth Across Bore: _____	_____

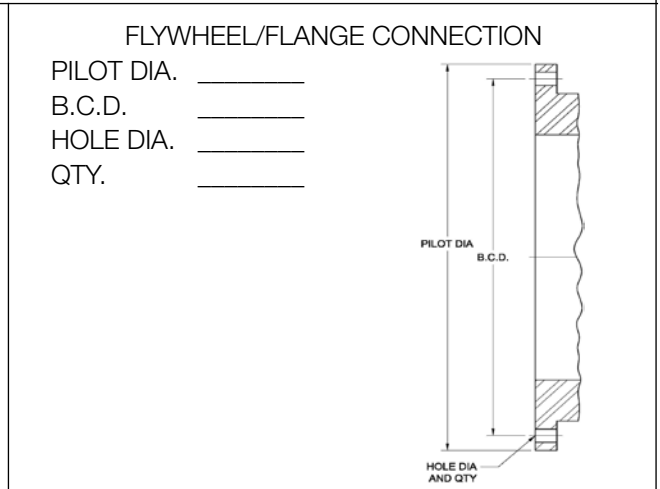
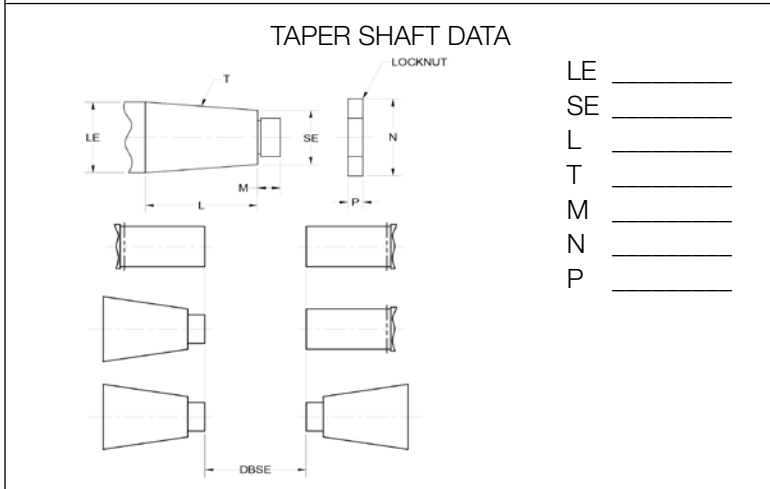

STANDARD ADAPTER SIZES							
Size	O.D. (in)	SAE Bolting			HD Bolting		
		P.C.D. (in)	Hole Qty.	Hole Size (in)	P.C.D. (in)	Hole Qty.	Hole Size (in)
10	10.375	9.625	6	0.406	9.500	8	0.469
12	12.375	11.625	8	0.406	11.500	8	0.531
14	13.875	13.125	8	0.406	12.500	8	0.656
18	18.375	17.250	8	0.531	16.750	8	0.781
20	20.375	19.250	8	0.531	18.500	8	0.906
22	22.500	21.375	6	0.656	20.500	8	1.031
26	26.500	25.250	12	0.656	24.500	12	1.031
28	28.875	27.250	12	0.781	26.875	12	1.031



# Application Data Sheet

---

Additional Comments: \_\_\_\_\_  
\_\_\_\_\_  
\_\_\_\_\_  
\_\_\_\_\_  
\_\_\_\_\_

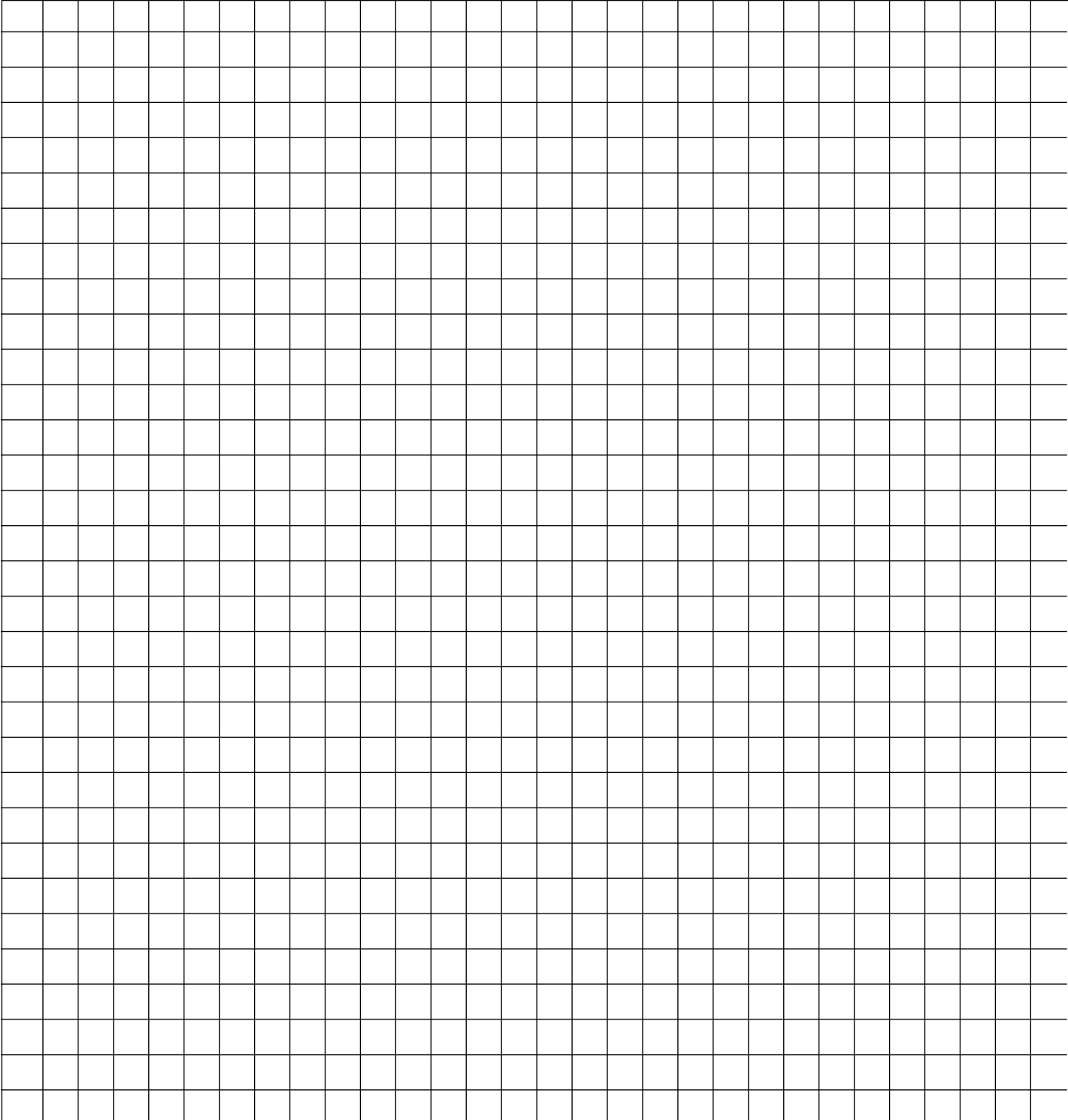

Sketch Area





# Premier Industrial Company Leading Brands

## OTHER PRODUCT SOLUTIONS FROM **ALTRA MOTION**

Our comprehensive product offerings include various types of clutches and brakes, overrunning clutches, engineered bearing assemblies, gearing and gear motors along with linear motion products, belted drives, couplings, limit switches, precision motors, drives & controls, miniature motors and engine braking systems. With thousands of product solutions available, Altra provides true single source convenience while meeting specific customer requirements. Many major OEMs and end users prefer Altra products as their No. 1 choice for performance and reliability.

[WWW.ALTRAMOTION.COM](http://WWW.ALTRAMOTION.COM)



### **Electric Clutches & Brakes**

Inertia Dynamics  
Matrix  
Stromag  
Warner Electric



### **Precision Motors & Automation**

Kollmorgen



### **Heavy Duty Clutches & Brakes**

Industrial Clutch  
Stromag  
Svendborg Brakes  
Twiflex  
Wichita Clutch



### **Miniature Motors**

Portescap



### **Overrunning Clutches**

Formsprag Clutch  
Marland Clutch  
Stieber



### **Linear Systems**

Thomson



### **Engineered Couplings & Universal Joints**

Ameridrives  
Bibby Turboflex  
Guardian Couplings  
Huco  
Lamiflex Couplings  
Stromag  
TB Wood's



### **Engine Braking Systems**

Jacobs Vehicle Systems



### **Gear Drives & Gear Motors**

Bauer Gear Motor  
Boston Gear  
Delroyd Worm Gear  
Nuttall Gear



### **Specialty Components**

Kilian  
Stromag  
TB Wood's



## The Brands of Altra Motion

### Couplings

- Ameridrives**  
www.ameridrives.com
- Bibby Turboflex**  
www.bibbyturboflex.com
- Guardian Couplings**  
www.guardiancouplings.com
- Huco**  
www.huco.com
- Lamiflex Couplings**  
www.lamiflexcouplings.com
- Stromag**  
www.stromag.com
- TB Wood's**  
www.tbwoods.com

### Linear Systems

- Thomson**  
www.thomsonlinear.com

### Geared Cam Limit Switches

- Stromag**  
www.stromag.com

### Engineered Bearing Assemblies

- Kilian**  
www.kilianbearings.com

### Electric Clutches & Brakes

- Matrix**  
www.matrix-international.com
- Stromag**  
www.stromag.com
- Warner Electric**  
www.warnerelectric.com

### Belted Drives

- TB Wood's**  
www.tbwoods.com

### Heavy Duty Clutches & Brakes

- Twiflex**  
www.twiflex.com
- Stromag**  
www.stromag.com
- Svendborg Brakes**  
www.svendborg-brakes.com
- Wichita Clutch**  
www.wichitaclutch.com

### Gearing & Specialty Components

- Bauer Gear Motor**  
www.bauergears.com
- Boston Gear**  
www.bostongear.com
- Delevan**  
www.delevan.com
- Delroyd Worm Gear**  
www.delroyd.com
- Nuttall Gear**  
www.nuttallgear.com

### Engine Braking Systems

- Jacobs Vehicle Systems**  
www.jacobsvehiclesystems.com

### Precision Motors & Automation

- Kollmorgen**  
www.kollmorgen.com

### Miniature Motors

- Portescap**  
www.portescap.com

### Overrunning Clutches

- Formsprag Clutch**  
www.formsprag.com
- Marland Clutch**  
www.marland.com
- Stieber**  
www.stieberclutch.com

## Altra Couplings Group

**TB Wood's**  
1-888-829-6637 – Press #5  
+44 (0) 1992 501900

**Bibby Turboflex**  
+44 (0) 1924 460801  
1-800-779-6993

**Huco**  
1-888-829-6637 – Press #5  
+44 (0) 1992 501900

**Ameridrives**  
1-920-593-2444  
+44 (0) 1924 460801  
1-814-480-5000

**Lamiflex Couplings**  
+55 11 5679 6553  
+55 11 5679 7735

**Guardian Couplings**  
1-219-874-5248

