

Stromag Vector® Couplings



Stromag

Founded in 1932, Stromag has grown to become a globally recognized leader in the development and manufacture of innovative power transmission components for industrial drivetrain applications. Stromag engineers utilize the latest design technologies and materials to provide creative, energy-efficient solutions that meet their customer's most challenging requirements.

Stromag's extensive product range includes flexible couplings, disc brakes, limit switches, an array of hydraulically, pneumatically, and electrically actuated brakes, and a complete line of electric, hydraulic and pneumatic clutches.

Stromag engineered solutions improve drivetrain performance in a variety of key markets including energy, off-highway, metals, marine, transportation, printing, textiles, and material handling on applications such as wind turbines, conveyor systems, rolling mills, agriculture and construction machinery, municipal vehicles, forklifts, cranes, presses, deck winches, diesel engines, gensets and stage machinery.

VISIT US ON THE WEB AT STROMAG.COM



Altra Motion

Altra is a leading global designer and producer of a wide range of electromechanical power transmission and motion control components and systems. Providing the essential control of equipment speed, torque, positioning, and other functions, Altra products can be used in nearly any machine, process or application involving motion. From engine braking systems for heavy duty trucks to precision motors embedded in medical robots to brakes used on offshore wind turbines, Altra has been serving customers around the world for decades.

Altra's leading brands include **Ameridrives**, **Bauer** Gear Motor, **Bibby** Turboflex, **Boston** Gear, **Delevan**, **Delroyd** Worm Gear, **Formsprag** Clutch, **Guardian** Couplings, **Huco**, **Jacobs** Vehicle Systems, **Kilian**, **Kollmorgen**, **Lamiflex** Couplings, **Marland** Clutch, **Matrix**, **Nuttall** Gear, **Portescap**, **Stieber**, **Stromag**, **Svendborg** Brakes, **TB Wood's**, **Thomson**, **Twiflex**, **Warner** Electric and **Wichita** Clutch.

VISIT US ON THE WEB AT ALTRAMOTION.COM



CONTENT

VECTOR® COUPLINGS: **IV**

COUPLING AT A GLANCE	4
Product range	
Torque Range	
Classifications	
Instruction for the designer	
Benefits include	
The torsional vibration analysis	
Stromag Vector® technical data	6
Series: VMF...W-K	8
Series: VMF...W-L	9
Series: VMF...W	10
Custom-built model	11

VECTOR® COUPLINGS PRODUCT RANGE

VMF...W-K SERIES

Nominal torque range 6600 – 22,500 Nm



Front perspective



Back perspective

VMW...W SERIES

Nominal torque range 6600 – 22,500 Nm



Front perspective



Back perspective

CLASSIFICATIONS



For survey of the coupling by a classification society, the regulations of the society have to be adhered to. The coupling characteristics may differ from the definitions given in this catalogue. Accordingly prepared data sheets are available on request.

A number of classification societies prescribe fail-safe devices on ships main drives.

TORQUE RANGE

- 6600 up to 22,500 Nm

INSTRUCTION FOR THE DESIGNER

All metal parts of the Stromag Vector® Coupling are made of steel or GGG.

The individual rubber elements can be mounted radially and can be connected to the coupling parts by bolted joints. The transmitted torque causes a tensile strain in the elements which is absorbed by the vulcanized nylon fabric inserts. Smooth running by coupling operation and less rotating radial forces are obtained by selection and arrangement of the single rubber elements according to their tensile characteristic curve.

Suitably stored, rubber flexible elements maintain their characteristics for several years without change. The parts need to be stored against oxygen, ozone, heat, light, moisture and solvents. The temperature in the store should be between +10°C und +25°C.

The relative humidity should not exceed 65%. Further details can be taken from DIN 7716 and ISO 2230.

Stromag – Flexible Couplings

COUPLING AT A GLANCE

The new Stromag Vector® coupling represents the next logical and consistent step in the evolution of our tried and tested GE rubber fabric coupling – a flexible coupling that has become successfully established on the market.

The new Vector® coupling concept is based on the experience we have gained from the most diverse application fields.

The result is a coupling that connects two shafts free of backlash. The coupling features a radial arrangement of segments in a compact design. This facilitates installation

and removal without the need to displace the drive units.

The capability of the highly flexible Stromag Vector® coupling to displace in all directions makes it ideal for applications on engines mounted on both rigid and flexible bearings. The coupling also exhibits progressive characteristics for the optimal configuration of the drive unit's vibration behaviour.

Our experts will support you by TVA torsional vibrations analysis for your drivetrain.

What can the Stromag Vector® do for you?

It is very compact because its rubber-fabric elements exhibit a high power density

It minimizes your costs because the special rubber-fabric elements enhance the service life of the Vector® coupling

It saves valuable working time because the elastomer elements radial mounting facilitates installation and removal without the need to displace the machine

It adjusts to your needs because it can displace in all directions and can be installed easily on engines mounted on both rigid and flexible bearings

Add on features compact design - outstanding ventilation - zero backlash - reduced installation times - low reactive forces



Technical data

Vector coupling size	Nominal torque T_{KN} Nm	Maximum torque		Adm. alternating torque T_{Kw} Nm	Adm. Speed n_{max} min ⁻¹	Adm. axial displacement ΔK_a mm	Axial stiffness C_a kN/mm 3) 4)	Adm. radial displacement ΔK_r mm 7)
		T_{Kmax1} Nm 1)	T_{Kmax2} Nm 2)					
V...20	6600	13200	19800	3300	2300	8	0,56	4
V...30	9900	19800	29700	4950	2300	8	0,84	4
V...40	15000	30000	45000	7500	1800	9	0,85	5
V...50	22500	45000	67500	11300	1800	9	1,3	5

1) for transient repetitive vibrations during start / stop, clutching etc.

2) for rare occasional peak loads, e. g. short circuits in generators

3) Tolerances until $\pm 15\%$ related to the material are possible.

4) At torque T_{KN}

5) For: $T_w = 0.2 \cdot T_{KN}$; $f = 10 \text{ Hz}$; $\vartheta = 30^\circ\text{C}$

THE TORSIONAL VIBRATION ANALYSIS



Stromag's Know-how in Torsional Vibration Analysis (TVA) constitutes the core of each coupling design. It provides a comprehensive analysis of loads in the crankshaft, coupling and driven side to ensure that no critical speeds occur during operation. Unevenly rotating systems can severely degrade product quality and cause great harm to the powertrain. On a daily basis, the TVA experts at Stromag work on the challenge of detecting such deviations by measuring them and protecting the entire powertrain with ideal product selection. Stromag is capable of calculating stationary and transient operating conditions considering the stiffness and damping of the elastomers.

Adm. radial displacement	Radial stiffness	Torsional stiffness, depending on the preload					Relative damping	Adm. dumping power
$\Delta K_{r, \max}$ mm	C_r kN/mm 3) 4)	$C_{1, \text{dyn}}$ kNm/rad 3) 5)					Ψ 3) 5)	$P_{KV 60}$ 8)
		$T_{KN} \leq 0$ 6)	$0,2 \times T_{KN}$	$0,4 \times T_{KN}$	$0,8 \times T_{KN}$	$1,0 \times T_{KN}$		
8	1,6	24	62	144	206	234	0,8	840
8	2,4	36	93	216	310	352	0,8	1260
10	2,6	48	138	364	527	610	0,8	1000
10	3,9	72	207	546	790	915	0,8	1500

6) This value is constant for the torque range from 0 to $-0,3 \cdot T_{KN}$

7) At $n_{\max} = 600 \text{ rpm}$, for higher speed ratings:

$$\Delta K_r(n) = \sqrt{\frac{600 \text{ min}^{-1}}{n}} \cdot \Delta K_r$$

8) The value $P_{KV 60}$ describes the damping power to be absorbed over 60 minutes. Permanently absorbed damping power

$$P_{KV \infty} = 0,5 \cdot P_{KV 60}$$

Stromag – Flexible Couplings

Stromag Vector® Couplings

Series: VMF...W-K

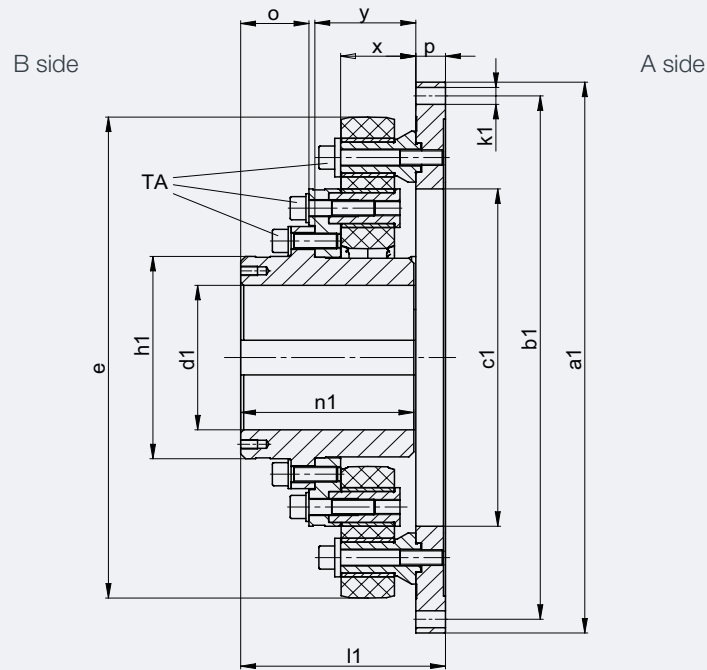

Coupling size	VMF 20 W 14"-K	VMF 20 W 18"-K	VMF 30 W 14"-K	VMF 30 W 18"-K	VMF 40 W 21"-K	VMF 40 W 24"-K	VMF 50 W 21"-K	VMF 50 W 24"-K
Diameter								
a1	466,7	571,5	466,7	571,5	673,1	733,4	673,1	733,4
b1	438,2	542,9	438,2	542,9	641,4	692,2	641,4	692,2
c1	350	350	350	350	480	480	480	480
e	499	499	499	499	660	660	660	660
h1	210	210	210	210	270	270	270	270
d1 _{max}	150	150	150	150	190	190	190	190
k1	8x 13,5	6x 17,5	8x 13,5	6x 17,5	12x 17,5	12x 20	12x 17,5	12x 20
Lengths: mm								
l1	207	207	207	207	262	262	262	262
n1	175	175	175	175	220	220	220	220
o	69	69	69	69	88	88	88	88
p	30	30	30	30	42	42	42	42
x	76	76	76	76	94	94	94	94
y	102	102	102	102	126	126	126	126
Mass: kg								
m *	67,4	84,8	71,9	89,3	160	172	168	180
Mass mom.of inertia: kgm ²								
JA side	1,001	2,225	1,109	2,333	5,133	6,683	5,497	7,047
JB side*	0,627	0,627	0,677	0,677	2,550	2,550	2,712	2,712

*) At max. bore dia.

Other coupling sizes on request

Series: VMF...W-L

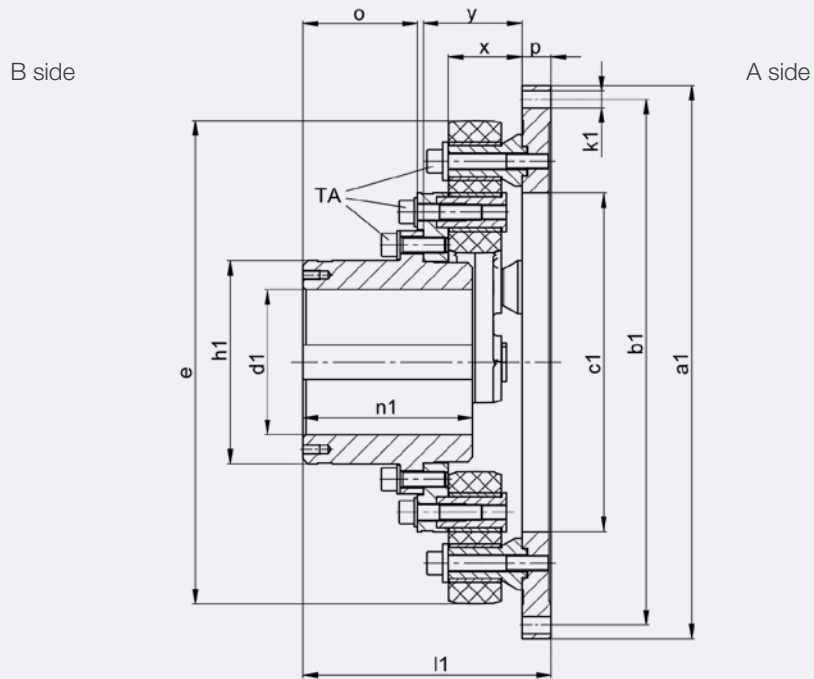

Coupling size	VMF 20 W 14"-L	VMF 20 W 18"-L	VMF 30 W 14"-L	VMF 30 W 18"-L	VMF 40 W 21"-L	VMF 40 W 24"-L	VMF 50 W 21"-L	VMF 50 W 24"-L
Diameter: mm								
a1	466,7	571,5	466,7	571,5	673,1	733,4	673,1	733,4
b1	438,2	542,9	438,2	542,9	641,4	692,2	641,4	692,2
c1	350	350	350	350	480	480	480	480
e	499	499	499	499	660	660	660	660
h1	210	210	210	210	270	270	270	270
d1 _{max}	150	150	150	150	190	190	190	190
k1	8x 13,5	6x 17,5	8x 13,5	6x 17,5	12x 17,5	12x 20	12x 17,5	12x 20
Lengths: mm								
l1	256	256	256	256	324	324	324	324
n1	175	175	175	175	220	220	220	220
o	118	118	118	118	150	150	150	150
p	30	30	30	30	42	42	42	42
x	76	76	76	76	94	94	94	94
y	102	102	102	102	126	126	126	126
Mass: kg								
m *	67,9	85,3	72,4	89,8	161	173	169	181
Mass mom.of inertia: kgm ²								
JA side	1,001	2,225	1,109	2,333	5,133	6,683	5,497	7,047
JB side *	0,632	0,632	0,682	0,682	2,565	2,565	2,727	2,727

*) at max. bore dia.
Other coupling sizes on request

Stromag – Flexible Couplings

Stromag Vector® Couplings

Series: VMW...W

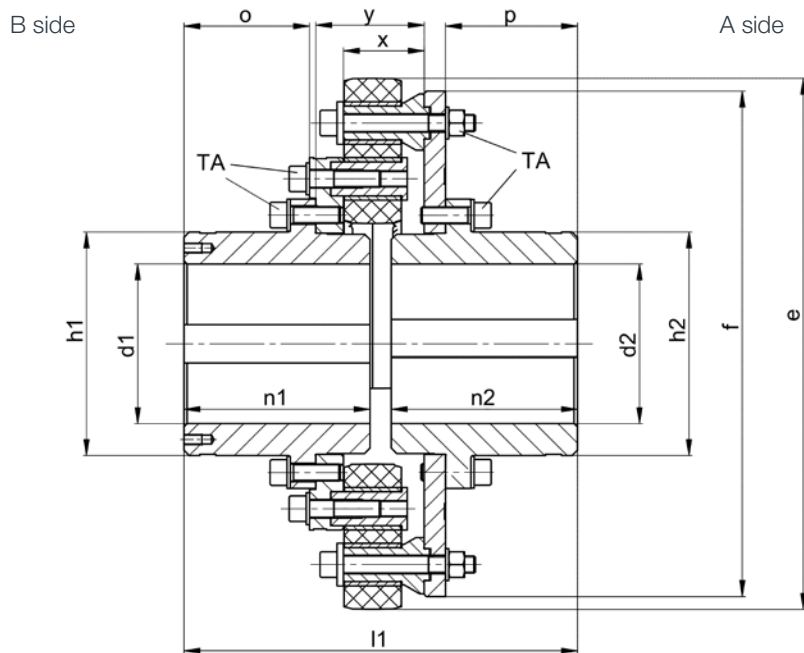

Coupling size	VMW 20 W	VMW 30 W	VMW 40 W	VMW 50 W
Diameter: mm				
e	499	499	660	660
f	475	475	654	654
h1	210	210	270	270
h2	210	210	270	270
d1 max	150	150	190	190
d2 max	150	150	190	190
Lengths: mm				
l1	370	370	464	464
n1	175	175	220	220
n2	175	175	220	220
o	118	118	158	150
p	124	124	172	156
x	76	76	94	94
y	102	102	126	126
Mass: kg				
m*	100	105	226	234
Mass mom. of inertia: kgm ²				
JA side*	1,245	1,359	5,240	5,626
JB side*	0,632	0,682	2,565	2,727

*) at max. bore dia.

custom-built model

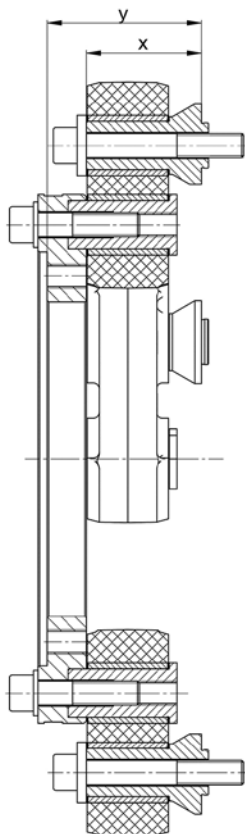
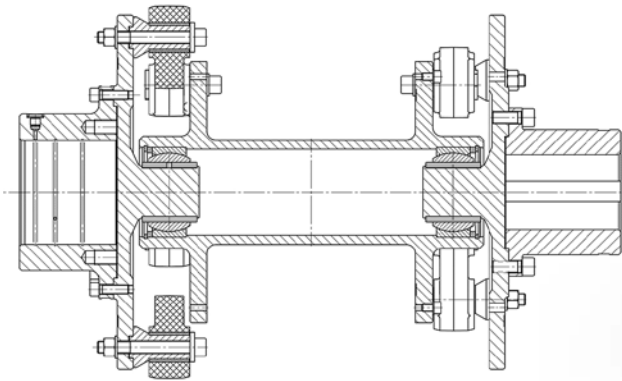

Stromag Facilities

Europe

Germany

Hansastraße 120
59425 Unna - Germany
+49 (0) 23 03 102 0

*Clutches & Brakes, Couplings,
Geared Cam Limit Switches, Discs*

Dessauer Str. 10
06844 Dessau-Roßlau - Germany
+49 (0) 340 2190 0

Electromagnetic Clutches & Brakes

France

Avenue de l'Europe
18150 La Guerche sur L'Aubois - France
+33 (0)2 48 80 72 72

Disc Brakes & Drum Brakes

Great Britain

Amphill Road
Bedford, MK42 9RD - UK
+44 (0)1234 324347

*Electromagnetic Clutches & Brakes,
Industrial Caliper Brakes*

North America

USA

31 Industrial Park Road
New Hartford, CT 06057 - USA
860-238-4783

Electromagnetic Clutches & Brakes

300 Indiana Highway 212
Michigan City, IN 46360 - USA
219-874-5248

Couplings

2800 Fisher Rd.
Wichita Falls, TX 76302 - USA
940-723-3400

*Geared Cam Limit Switches,
Industrial Caliper & Drum Brakes*

South America

Brasil

Avenida João Paulo Ablas, 2970
Jardim da Glória, Cotia - SP,
06711-250 - Brasil
+55 (11) 4615-6300

*Flexible Couplings, Bearing
Isolators, and Coupling Guards*

Asia Pacific

China

T40B -5, No. 1765 Chuan Qiao Road
Pudong 201206, Shanghai - China
Tel +86 21-60580600

*Clutches & Brakes, Electromagnetic
Clutches & Brakes, Couplings, Industrial
Caliper & Drum Brakes, Discs, Geared
Cam Limit Switches*

India

Gat No.: 448/14, Shinde Vasti, Nighoje
Tal Khed, Pune- 410 501
+91 2135 622100

*Clutches & Brakes, Electromagnetic
Clutches & Brakes, Couplings, Industrial
Caliper & Drum Brakes, Discs, Geared
Cam Limit Switches, Wind Brakes*

Altra Renewable Energy

Denmark

Jernbanevej 9
5882 Vejstrup
+45 63 255 255

Wind Brakes

The Brands of Altra Motion

Couplings

Ameridrives
www.ameridrives.com

Bibby Turboflex
www.bibbyturboflex.com

Guardian Couplings
www.guardiancouplings.com

Huco
www.huco.com

Lamiflex Couplings
www.lamiflexcouplings.com

Stromag
www.stromag.com

TB Wood's
www.tbwoods.com

Linear Systems

Thomson
www.thomsonlinear.com

Geared Cam Limit Switches

Stromag
www.stromag.com

Engineered Bearing Assemblies

Kilian
www.kilianbearings.com

Electric Clutches & Brakes

Matrix
www.matrix-international.com

Stromag
www.stromag.com

Warner Electric
www.warnerelectric.com

Belted Drives

TB Wood's
www.tbwoods.com

Heavy Duty Clutches & Brakes

Twiflex
www.twiflex.com

Stromag
www.stromag.com

Svendborg Brakes
www.svendborg-brakes.com

Wichita Clutch
www.wichitaclutch.com

Gearing & Specialty Components

Bauer Gear Motor
www.bauergears.com

Boston Gear
www.bostongear.com

Delevan
www.delevan.com

Delroyd Worm Gear
www.delroyd.com

Nuttall Gear
www.nuttallgear.com

Engine Braking Systems

Jacobs Vehicle Systems
www.jacobsvehiclesystems.com

Precision Motors & Automation

Kollmorgen
www.kollmorgen.com

Miniature Motors

Portescap
www.portescap.com

Overrunning Clutches

Formsprag Clutch
www.formsprag.com

Marland Clutch
www.marland.com

Stieber
www.stieberclutch.com

Neither the accuracy nor completeness of the information contained in this publication is guaranteed by the company and may be subject to change in its sole discretion. The operating and performance characteristics of these products may vary depending on the application, installation, operating conditions and environmental factors. The company's terms and conditions of sale can be viewed at <http://www.altramotion.com/terms-and-conditions/sales-terms-and-conditions>. These terms and conditions apply to any person who may buy, acquire or use a product referred to herein, including any person who buys from a licensed distributor of these branded products.

©2021 by Stromag LLC. All rights reserved. All trademarks in this publication are the sole and exclusive property of Stromag LLC or one of its affiliated companies.