

# Centric Overload & Centrifugal Clutches Solutions To Torque/Timing Control



# Boston Gear

Boston Gear offers the industry's largest line up of reliable speed reducers, gearing and other quality drivetrain components.

With more than 125 years of frontline experience, Boston Gear is recognized globally as a premier resource for extremely reliable, high-performance power transmission components. Boston Gear offers the industry's most comprehensive product array featuring more than 30,000 standard products combined with the ability to custom engineer unique solutions when required. Product lines include standard enclosed gear drives, custom speed reducers, AC/DC motors, DC drives and Centric brand overload clutches and torque limiters.

VISIT US ON THE WEB AT  
**BOSTONGEAR.COM**



# Altra Motion

Altra is a leading global designer and producer of a wide range of electromechanical power transmission and motion control components and systems. Providing the essential control of equipment speed, torque, positioning, and other functions, Altra products can be used in nearly any machine, process or application involving motion. From engine braking systems for heavy duty trucks to precision motors embedded in medical robots to brakes used on offshore wind turbines, Altra has been serving customers around the world for decades.

Altra's leading brands include **Ameridrives**, **Bauer** Gear Motor, **Bibby** Turboflex, **Boston Gear**, **Delevan**, **Delroyd** Worm Gear, **Formsprag** Clutch, **Guardian** Couplings, **Huco**, **Jacobs** Vehicle Systems, **Kilian**, **Kollmorgen**, **Lamiflex** Couplings, **Marland** Clutch, **Matrix**, **Nuttall** Gear, **Portescap**, **Stieber**, **Stromag**, **Svendborg** Brakes, **TB Wood's**, **Thomson**, **Twiflex**, **Warner** Electric and **Wichita** Clutch.

VISIT US ON THE WEB AT **ALTRAMOTION.COM**



# Boston Gear Centric Clutch Products

---

## Table of Contents

INTRODUCTION.....	2
PRODUCT SELECTION REFERENCE GUIDE.....	3
QUICK SELECTION GUIDE.....	4-5
CENTRIGARD™ OVERLOAD CLUTCHES.....	7
TRIG-O-MATIC LITE OVERLOAD CLUTCHES	
LOR SERIES .....	9
TRIG-O-MATIC OVERLOAD CLUTCHES	
ORC SERIES MODEL S.....	15
ORC SERIES MODEL F .....	26
MODEL H OVERLOAD CLUTCHES	
HOR SERIES (H1600) .....	35
WOR SERIES (H1900) .....	45
POR SERIES (H2000) .....	53
PNEUMATIC OVERLOAD DISCONNECT CLUTCHES	
PDC SERIES .....	63
VARITORQUE PNEUMATIC OVERLOAD CLUTCHES	
VOR SERIES .....	69
CENTRIFUGAL CLUTCHES	
CCC SERIES.....	75
NLS™ CENTRIFUGAL CLUTCHES.....	83
SURE-GRIP BUSHINGS.....	90
ENGINEERING INFORMATION.....	95

# Boston Gear Centric Clutch Products

## Centric Clutch History

Since 1948, Centric Clutch has been manufacturing Centrifugal Clutches for a wide range of industries. Designed as a means to connect power in a drive train with soft start or delay capabilities, Centric's centrifugal clutch was the industry's first overload protection device with repeatable performance.

Capitalizing on the need for a dependable and repeatable torque limiter, Centric produced the Trig-O-Matic Overload Release Clutch, the original single position, mechanical torque limiting device. Customer requests for a simple cost effective overload device led to the development of the Trig-O-Matic Lite and Centrigard™ which further solidified the company's position as an industry leader.

Centric revolutionized torque limiting technology with the VariTorque, the first single position pneumatic overload clutch. The VariTorque was designed to meet the specific needs of paper converting machinery where large starting inertias, high production speeds, and the possibility of equipment failure is great.

The addition of three Model H clutches have helped to position the Centric family of products as one of the industry's premier offerings of mechanical overload protection devices.

By combining Centric's industry expertise and engineering capabilities with Boston Gear's distributor network and responsiveness oriented culture, customer expectations will continue to be met and exceeded. In a world where down time is unacceptable, Boston Gear will continue the Centric tradition of producing high quality, durable clutches quickly and efficiently. Yesterday, today, and tomorrow, Boston Gear will provide you, our valued customers, with the answers to all of your torque overload needs.

## Applications

Because we realize that no two torque overload applications are the same, Boston Gear is available to put over 120 years of mechanical power transmission expertise to work for you.

## Contact Us

Feel free to contact our technical support team at [www.centricclutch.com](http://www.centricclutch.com) or call us at 704-688-7324 or Tech Support at 800-816-5608.

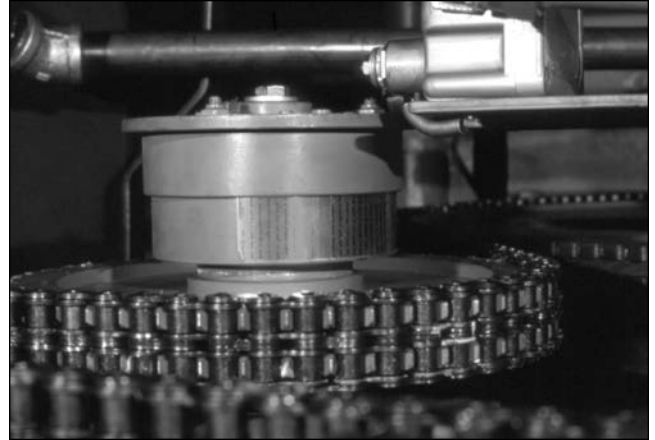

**Trig-O-Matic Overload Clutch  
Packaging Machine Case Palletizer**

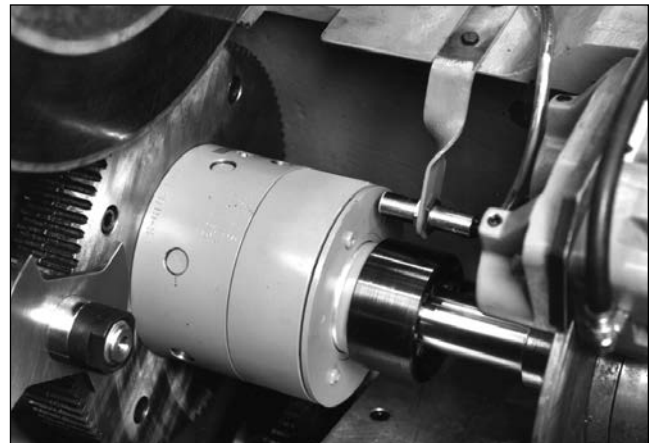











**VariTorque Overload Clutch  
Paper Converting Machine**



**H1900 Overload Clutch  
Water Treatment Plant**

# Boston Gear Centric Clutch Products

<p><b>CENTRIGARD™ OVERLOAD CLUTCHES</b></p>	 <p>Pages 7-8</p>		
<p><b>TRIG-O-MATIC LITE™ OVERLOAD CLUTCHES</b></p>	 <p>LOR SERIES Pages 9-13</p>		
<p><b>TRIG-O-MATIC™ OVERLOAD CLUTCHES</b></p>	 <p>ORC SERIES MODEL S Pages 15-25</p>	 <p>ORC SERIES MODEL F Pages 26-33</p>	
<p><b>MODEL H OVERLOAD CLUTCHES</b></p>	 <p>HOR SERIES Pages 35-43</p>	 <p>WOR SERIES Pages 45-51</p>	 <p>POR SERIES Pages 53-62</p>
<p><b>PNEUMATIC DISCONNECT CLUTCHES</b></p>	 <p>PDC SERIES Pages 63-67</p>		
<p><b>VARITORQUE™ OVERLOAD CLUTCHES</b></p>	 <p>VOR SERIES Pages 69-73</p>	<p><b>NLS™ CENTRIFUGAL CLUTCHES</b></p>	
<p><b>CENTRIC CENTRIFUGAL CLUTCHES</b></p>	 <p>CCC SERIES Pages 75-82</p>		

# Boston Gear Centric Clutch Products

## Quick Selection Guide

### Boston Gear Overload Clutches

Spring Loaded Mechanical Torque Limiters									
Model	Centrigard	LOR	ORC-F	ORC-SA	ORC-SB	ORC-SP	ORC-SM	HOR	WOR
Applications	Packaging Duty	Packaging Duty	Packaging Duty	Packaging Duty	Packaging Duty	Packaging Duty	Packaging Duty	Washdown Duty	Wastewater Duty
Torque Repeatability	+/-10%	+/-10%	+/-10%	+/-10%	+/-10%	+/-10%	+/-10%	+/-10%	+/-10%
Reset Type	Fully Automatic	Fully Automatic	Fully Automatic	Fully Automatic	Semi-Automatic	Manual Reset	Manual Reset	Fully Automatic	Automatic or Manual
Shut down mechanism	Plate style automatic reset	Plate style automatic reset	Plate style automatic reset	Pin style automatic reset	Plate style manual reset	Plate style manual reset	Pin style automatic reset	Plate style automatic reset	Plate style automatic reset
Free wheeling	No	No	No	No	No	Yes	Yes	No	Yes/No
Reset Position	Single	Single	Single	Single	Single	Single	Single	Single	Four
Maximum RPM	1000	1000	500	1800	1800	1800	1800	500	50
Minimum Torque Range (Inch-lbs)	50	200	70	35	35	35	35	25	850
Maximum Torque Range (inch-lbs)	1,200	5,000	10,000	25,000	25,000	25,000	25,000	50,000	30,000
Minimum bore size (inch)	1/2	1/2	1/2	1/2	1/2	1/2	1/2	7/16	3/4
Maximum bore size (inch)	1-1/4	2-3/4	2-3/4	3-15/16	3-15/16	3-15/16	3-15/16	3-5/8	4-1/4
Mounting Options	Sprocket/Pulley	Sprocket/Pulley	Sprocket/Pulley/Couplings	Sprocket/Pulley/Couplings	Sprocket/Pulley/Couplings	Sprocket/Pulley/Couplings	Sprocket/Pulley/Couplings	Sprocket/Pulley/Couplings	Sprocket/Pulley
Page Number	7	11	27	19	19	19	19	37	47



**Trig-O-Matic Lite**



**Trig-O-Matic**



**H1600**



**Centrigard**



**H1900**

# Boston Gear Centric Clutch Products

## Quick Selection Guide

### Boston Gear Overload Clutches

Pneumatic Torque Limiters			
Model	POR	PDC	VOR
Applications	High Speed Washdown Duty	Washdown Duty	Washdown Duty
Torque Repeatability	+ -5%	+ -5%	+ -5%
Reset Type	Fully Automatic	Fully Automatic	Fully Automatic
Shut down mechanism	Plate style automatic reset	Plate style automatic reset	Plate style automatic reset
Free wheeling	No	Yes	No
Reset Position	Single	Single	Single
Maximum RPM	3600	1800	1000
Minimum Torque Range (Inch-lbs)	120	300	250
Maximum Torque Range (inch-lbs)	33,000	4,000	10,000
Minimum bore size (inch)	7/16	5/8	5/8
Maximum bore size (inch)	3-1/4	1-3/4	2-3/16
Mounting Options	Sprocket/Pulley/Couplings	Sprocket/Pulley	Sprocket/Pulley
Page Number	55	65	71



H2000



Varitorque



PDC

### Centrifugal Clutches

Centrifugal Clutches				
Model	Type A	Type AVL	Type H	Type NLS
Applications	Heavy Duty	Heavy Duty	Heavy Duty	Heavy Duty
Max. HP	2300	2300	800	8360
Max. Bore	7.0	7.0	4-3/4	8.0
Spring Controlled	Yes	Yes	Yes	Yes
Free Engagement	Yes	Yes	No	Yes
Bored to Size	Yes	Yes	Yes	Yes/No
Bushing Mounted	No	No	No	Yes
Vertical Lift Out	No	Yes	No	No
Pulley/PTO Mounted	No	No	Yes	No
Steel Banded	Yes/No	Yes/No	Yes/No	Yes/No
Torque Limiting	Yes	No	No	Yes/No
Page Number	76	76	76	84



Type AVL



Type A



Type NLS



Type H





# Centrigard™ Overload Clutch

Centric products have long been known as the most durable overload clutches on the market. Today we have added a maintenance friendly clutch that provides zero backlash. This clutch will be ready to limit the transmitted torque no matter if the overload jam is once a year or many times per day.

## Features

- Compact design with fewer components
- Widest torque range in its class: 50 to 1,200 in. lbs.
- Fully automatic reset
- Roller Detent
- Bi-directional single position clutch
- Hardened components rated for thousands of overloads
- Maximum torque limit stop
- Corrosion resistant hard-anodized housing
- Durable stainless steel limit switch plate/trip plate for remote overload detection
- Bored to size (1.250 inch max. bore size)
- Designed and manufactured in the U.S.A.
- Torq/Gard Interchange



## Centrigard Clutch Part Numbering System

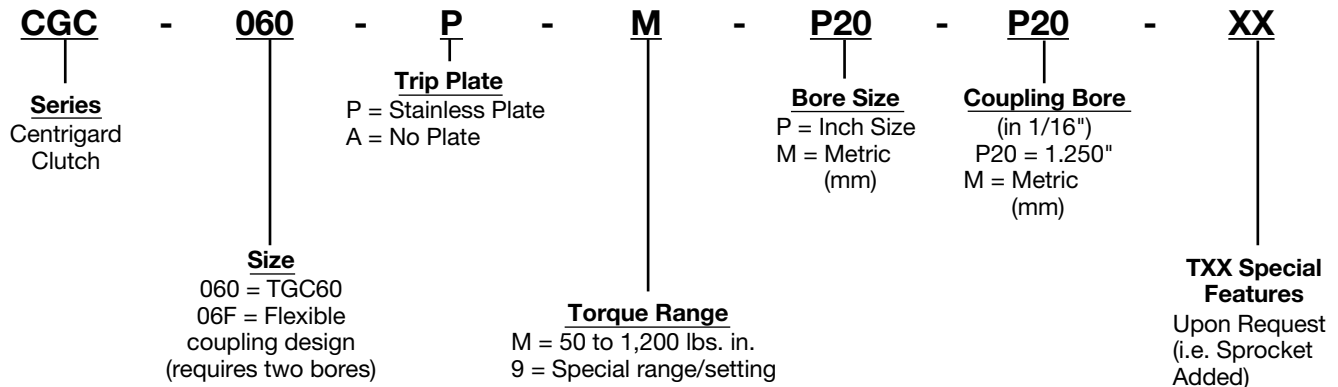

# Centrigard™ Overload Clutch

## Type F Flexible Coupling

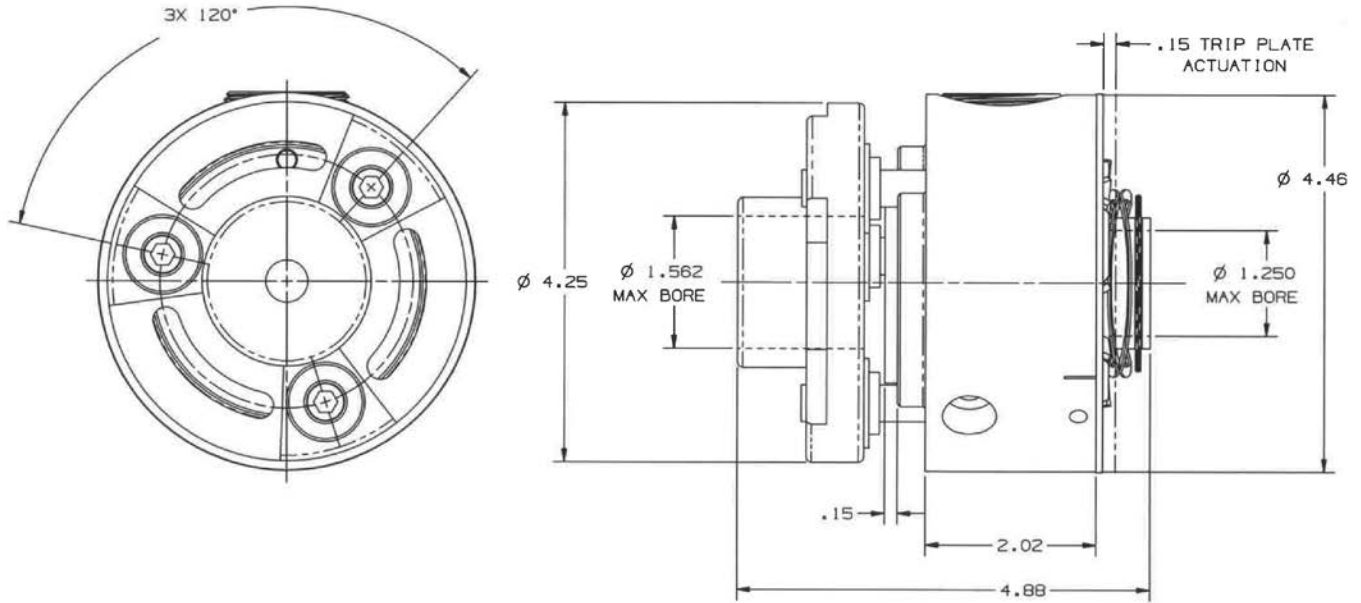

Clutch Size	Torque Code	Clutch Bore Max (in.)	Coupling Max. (2) Bore	Coupling Max. (1) Bore	Torque Range (Lb. In.)		Maximum RPM	Weight (lbs.)
					Min	Max		
060	M	1.25	1.562	1.500	50	1200	1000	5.0

Refer to page 96 for a complete list of bore codes.

(1) Square Key, (2) Flat Key

See ORC1 coupling on page 22 for misalignment limits.

## Sprocket Mount

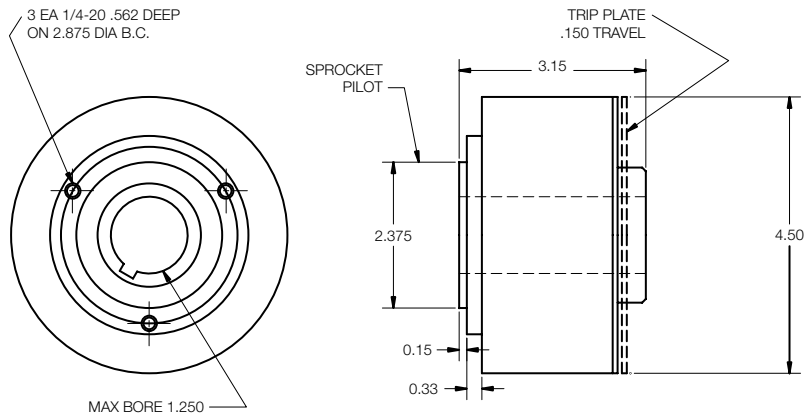

### Minimum Acceptable Plate Sprocket Mounts

Clutch Size	Minimum Number of Teeth per Pitch Size				
	#35 3/8 Pitch	#40 1/2 Pitch	#50 5/8 Pitch	#60 3/4 Pitch	#80 1 Pitch
CGC060	31	24	20	17	14

# Trig-O-Matic Lite Mechanical Overload Clutches LOR Series

---



## Section Contents

FEATURES .....	10
OPERATING PRINCIPLES .....	10
SELECTION .....	11
HOW TO ORDER.....	11
RATINGS AND DIMENSIONS .....	12
MOUNTING ARRANGEMENTS.....	13

# Trig-O-Matic Lite Overload Clutches LOR Series

## Features

- Simple cost-effective design
- Bi-directional operation
- Single position reset
- Reliable limit switch actuating plate
- Easy torque adjustment
- Maximum torque limit stop
- Through shaft or end shaft mounting
- Large bore capacity
- Bored to size
- Torq/Gard interchange

## Operating Principles

The LOR Series Trig-O-Matic Lite is an automatic reset, roller detent style clutch. It was designed to be cost-effective without sacrifice to accurate and dependable disconnect protection for mechanical equipment. Refer to Figure 1.

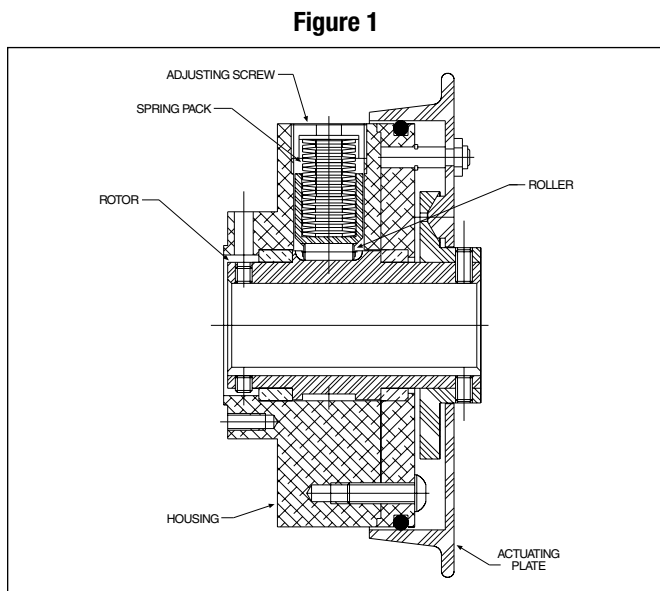

Torque transmission between the roller and the rotor is the key to the disengagement of the clutch. The roller is held in the detent of the rotor by the radial load generated by compressing the spring pack. This load determines the torque capacity of the clutch. Increasing or decreasing the spring compression provides an adjustment to the torque capacity. When a torque overload condition occurs, the roller moves out of the detent and free-wheels much like a needle bearing. This rolling action increases the efficiency in which the clutch operates and reduces any fluctuation of the torque setting caused by frictional changes. Refer to Figure 2.

Figure 2

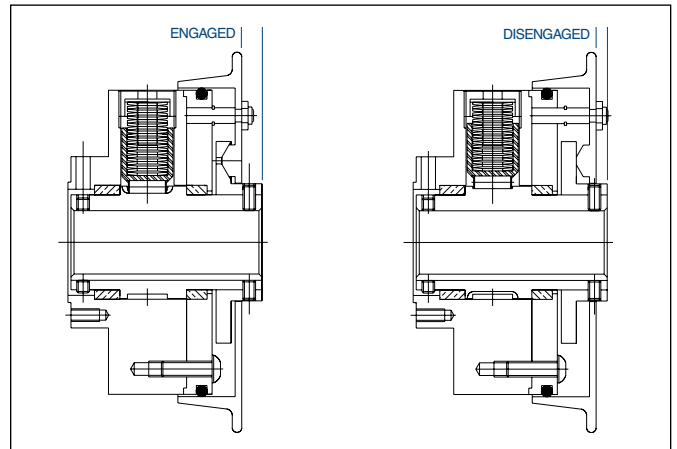

The movement of the actuating plate during disengagement can be used to trip a limit switch or sensor and signal a torque overload condition. The drive should be shut down immediately and the source of the overload detected and cleared. The automatic reset feature of the clutch allows it to re-engage in its single position without manual assistance. Simply restart the drive and the clutch is again ready to provide accurate and dependable disconnect protection for your equipment.

## Flange with Proximity Plate

As the Trig-O-Matic Lite overload clutch is disengaged, the flange (Actuating Plate) moves 0.18 inches. This movement can be used to trip a mechanical limit switch and signal a torque overload condition. Many applications require that a proximity sensor be used in place of the mechanical limit switch which necessitates the addition of a metallic plate to the nonmetallic flange. This metallic flange can be ordered on the Trig-O-Matic Lite overload clutch by indicating a letter P in the catalog number after the size (e.g., LOR-060P-AP16).

# Trig-O-Matic Lite Overload Clutches

## Selection

- Determine overload release torque by one of these methods:
  - Use the torque formula with horsepower and RPM specific to the selected clutch location. A service factor may be required for high inertia starts, reversing or peak load conditions, (refer to Page 86 for service factor information. For average applications, a service factor "SF" of 1.25 is recommended):
 
$$\text{Torque (Lb. In.)} = \frac{\text{HP} \times 63025}{\text{RPM}} \times \text{SF}$$
  - Determine the "weak link" in the drive train, (i.e. chain, reducer, belt or shaft). Select an overload release torque that is below the "weak link's" maximum torque rating.
  - Physically measure the drive torque with a torque wrench and size accordingly.
- Determine the bore size, keyway, and taper bore or straight bore bushing model.
- Refer to the Basic Selection Chart for the appropriate clutch size.
- Refer to Page 12 for ratings and dimensions.

**Basic Selection Chart**

Clutch Size	Bore		Torque Range (Lb. In.)	Maximum RPM
	Min	Max*		
060	.500	1.4375	200-700	1,000
200	1.000	2.1250	600-2,000	1,000

\*Max bores will require flat keys (supplied with unit).

## Torque Adjustment

Each clutch is tested throughout the torque range then set at the minimum torque range value at the factory. The torque dial label is indexed to a match mark on the clutch at the number "1" location. The torque dial label has eight hash marks evenly spaced at 45 degrees. To increase the torque, loosen the locking screw and turn the adjusting screw clockwise. When the desired torque value is achieved, secure the torque adjustment screw by tightening the locking screw.

**Torque Adjustment**

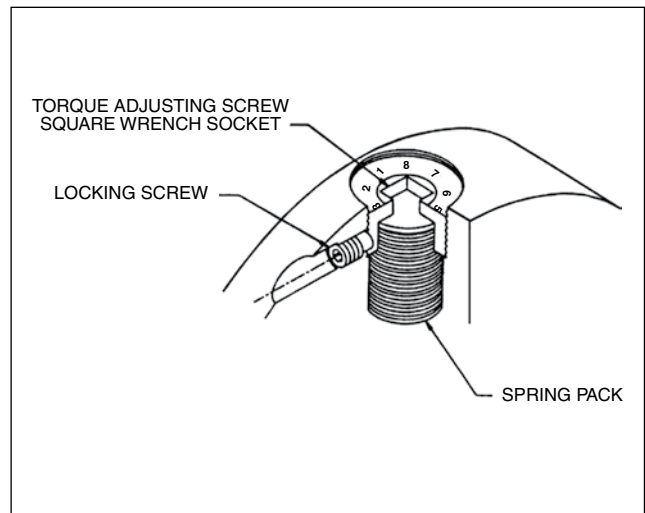

## LOR Series Part Numbering System

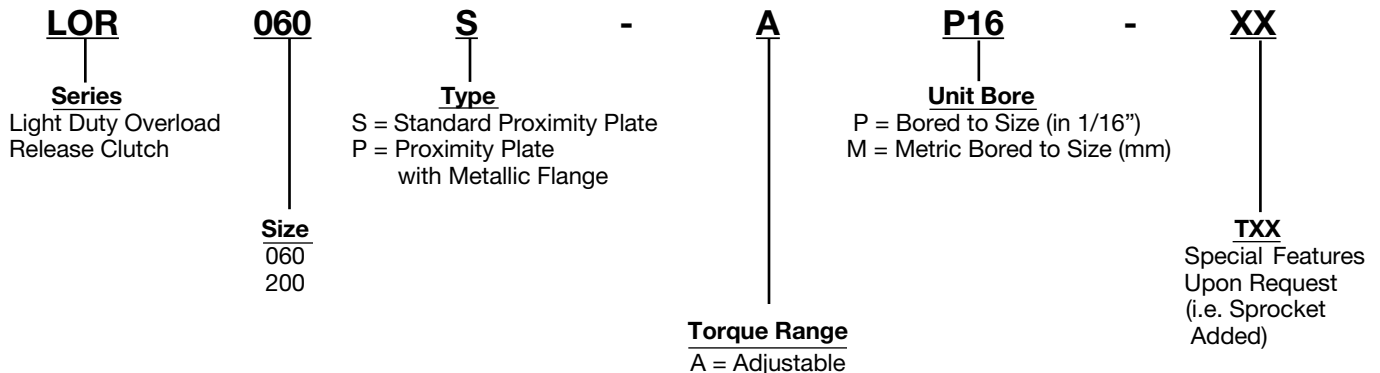

## How to Order

When ordering a Trig-O-Matic Lite LOR Series Overload Clutch, please include code letters/numbers for series, size, type, torque range, and unit bore. Not all combinations are possible. Please refer to Page 12 for details.

Example:

Required Size 060 Trig-O-Matic Lite Overload Clutch, standard flange, adjustable torque range, with a one inch bore:



# Trig-O-Matic Lite Overload Clutches LOR Series

## Straight Bore

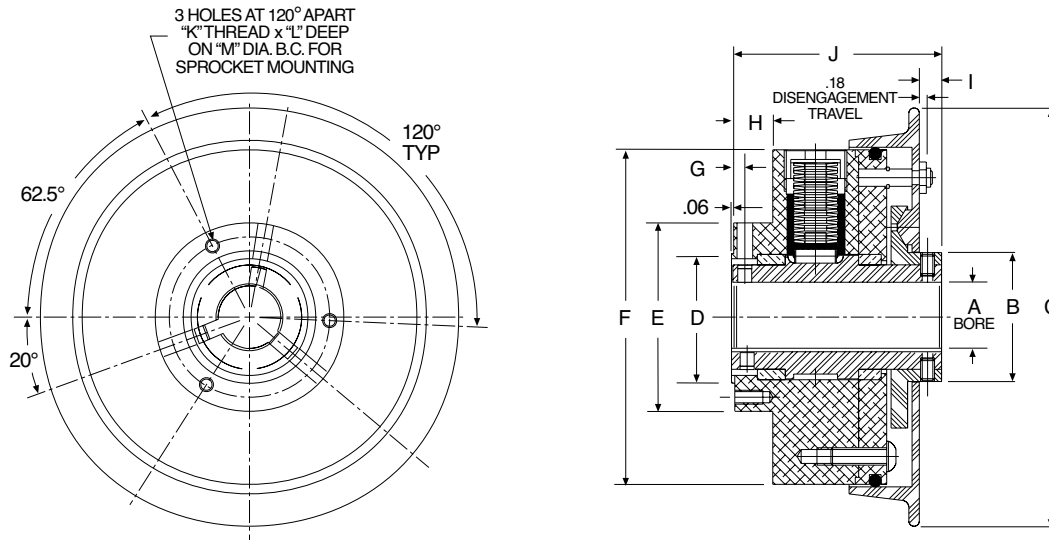

All Dimensions in Inches

Clutch Size	B	C	D +.002/-0.004	E	F	G	H	I	J	K	L	M
060	2.25	7.50	2.375	3.38	6.00	.24	.74	.40	3.77	1/4-20	0.56	2.875
200	2.98	9.50	3.250	5.25	8.00	.22	.94	.59	4.91	3/8-16	0.75	4.500

### Ratings

Clutch Size	A Bores (inch)			Torque Range (Lb.-In.)	Max. RPM*	WR <sup>2</sup> (Lb.-In. <sup>2</sup> )	Weight (Lbs.)
	Min	Max. (1)	Max (2)				
060	.5000	1.3750	1.4375	200-700	1,000	39	7.5
200	1.0000	2.0000	2.1250	600-2,000	1,000	181	19

\*Maximum RPM dependent on operation of clutch with limit switch and immediate shut down.

- (1) Square Key
- (2) Flat Key

### Bore Tolerances

Bores	Tolerance
0" to 1"	+.0005/-0.0000
1" to 3"	+.0010/-0.0000

### Standard Keyways

Bore Range Over – To	Square W x D
5/16 – 7/16	3/32 x 3/64
7/16 – 9/16	1/8 x 1/16
9/16 – 7/8	3/16 x 3/32
7/8 – 1-1/4	1/4 x 1/8
1-1/4 – 1-3/8	5/16 x 5/32
1-3/8 – 1-3/4	3/8 x 3/16
1-3/4 – 2-1/4	1/2 x 1/4
2-1/4 – 2-3/4	5/8 x 5/16

### Minimum Acceptable Plate Sprocket Mounts\*

Clutch Size	Minimum Number of Teeth per Pitch Size						
	#25 1/4 Pitch	#35 3/8 Pitch	#40 1/2 Pitch	#50 5/8 Pitch	#60 3/4 Pitch	#80 1 Pitch	#100 1-1/4 Pitch
	060	47	32	25	21	18	—
200	—	48	37	30	26	20	—

\*Please contact Boston Gear for Sprocket Clutch Assemblies.

Clutches are shipped set for the minimum torque value unless specified.

Refer to Page 11 for ordering information.

# Trig-O-Matic Lite Overload Clutches

## Suggested Mounting Arrangements

Boston Gear can provide assistance for virtually any drive layout. Plate sprockets, timing belt pulleys, gears, and couplings can be provided upon request.

**Plate Sprocket Mount with Through Shaft**

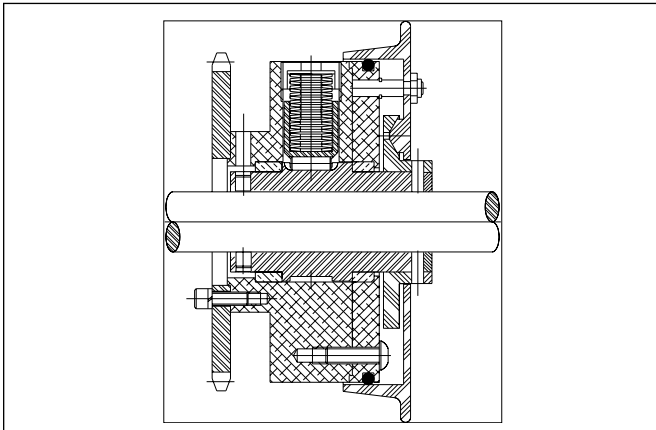

**Plate Sprocket Mount with End Shaft**

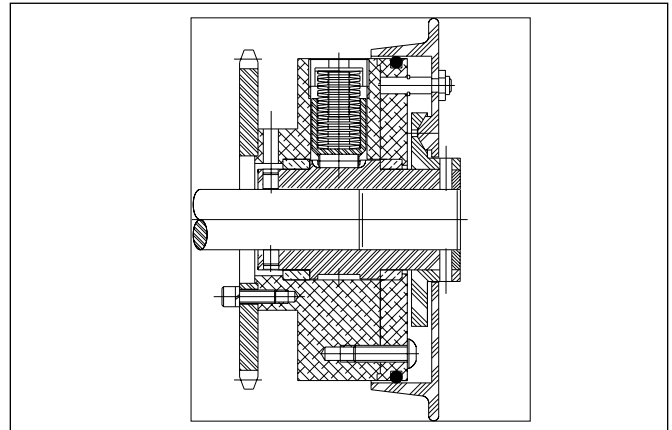

**Timing Belt Pulley Mount with Through Shaft**

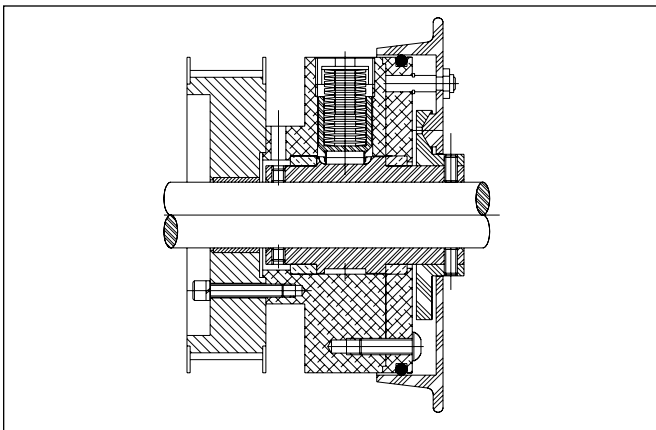

# Trig-O-Matic Lite Overload Clutches

---

## Torque Limiter Application Data

Fax To 800-816-5608

Please select your product intent below and provide as much application information as possible.

### 1. Application:

- New
- Existing  
– Replacement Model # \_\_\_\_\_

### 2. Power transmission requirements at clutch location:

- RPM \_\_\_\_\_
- Limiting Torque Level \_\_\_\_\_

### 3. Type:

- Mechanical (Spring Loaded)
- Pneumatic

### 4. Type:

- Fully Automatic Re-Engagement
- Manual (Free Wheeling)
- Semi Automatic (ORC model only)

### 5. Method of Torque Transmission:

- Flexible Coupling
  - Rigid Coupling
  - Sprocket Mount
- Sprocket Size and Tooth Count \_\_\_\_\_

### 6. Bore Size:

- Sprocket Mount (Clutch Bore) \_\_\_\_\_
- Coupling Mount (Clutch Bore) \_\_\_\_\_  
(Coupling Bore) \_\_\_\_\_

### 7. Shut Down Method:

- Prox Plate
- Pin Style (ORC only)
- None Required

Name: \_\_\_\_\_

Phone # \_\_\_\_\_

Fax # \_\_\_\_\_

Company \_\_\_\_\_

E-Mail \_\_\_\_\_

Use the space below to note any relevant application data or to detail your question.

---

---

---

---

---

---

---

---

---

---

---

---

---

---

---



# Trig-O-Matic Mechanical Overload Clutches ORC Series



## Section Contents

FEATURES .....	16
SELECTION .....	17
STANDARD MODEL S	
Operating Principles .....	18
How to Order .....	19
Ratings and Dimensions .....	20
Mounting and Sprocket Selection .....	21
Options .....	25
MODEL F	
Operating Principles .....	26
How to Order .....	27
Ratings and Dimensions .....	28
Mounting and Sprocket Selection .....	29
Options .....	33

# Trig-O-Matic Overload Clutches ORC Series

## Features

- Bi-directional operation
- Single positioning for re-engagement at the exact cycle point at which it released
- Limit switch actuation for remote detection of overload condition
- Completely enclosed for dirty applications
- Automatic or manual reset
- Various configurations for direct and indirect drives
- Six sizes (Model F - five sizes) to accommodate various bore and torque ranges

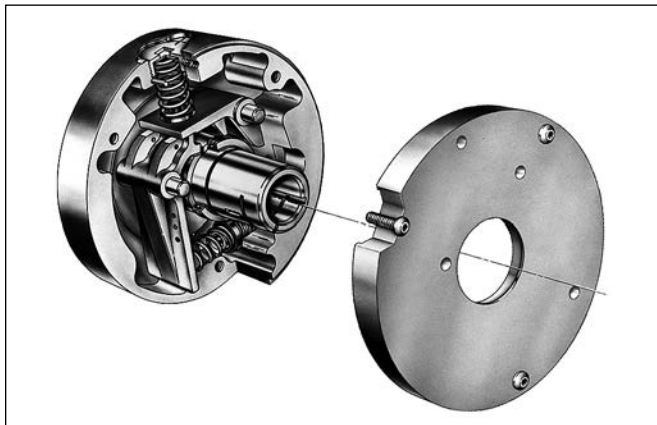

**Standard Model S**

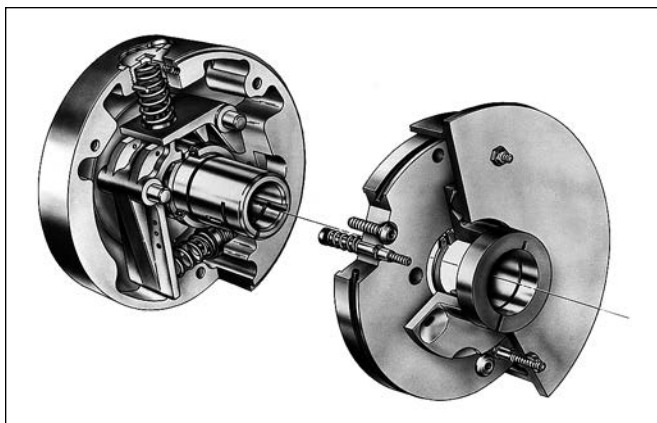

**Fully Automatic Model F**

The Trig-O-Matic's unique "Trigger" action design disconnects the load at the instant an overload occurs and at the exact torque limit you set. When the overload condition is corrected, the clutch resets at the exact cycle point and torque at which it released.

The ORC Series Trig-O-Matic Overload Clutch is available in two models: the Standard Model S and the Fully Automatic Model F. Both provide single position engagement and a means to signal an overload condition. Each model is available in various sizes and types to adapt to your drive train. They incorporate reliability, repeatability and adjustability to protect your machinery from costly damage or downtime.

## Applications

The ORC Series Trig-O-Matic Overload Release Clutch can be applied on any drive train where the protection of reducers, indexers, chain, sprockets or product is required. It can replace less precise and less reliable devices such as shear pins and friction clutches.

Typical applications include: packaging machinery, paper converting machinery, baking equipment, bottling and capping machinery, indexing machinery, labeling machinery, conveyors, presses and water treatment equipment.

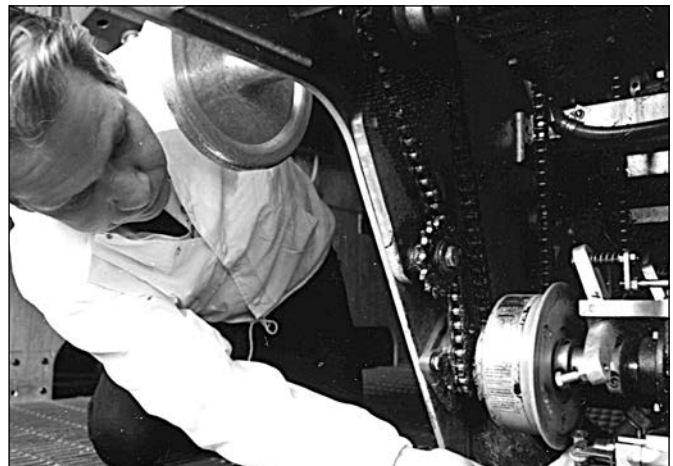

# Trig-O-Matic Overload Clutches

## Selection

- Determine the overload release torque by one of these methods:
  - Use the torque formula with horsepower and RPM specific to the selected clutch location. A service factor may be required for high inertia starts, reversing or peak load conditions, (refer to Page 98 for service factor information. For average applications, a service factor "SF" of 1.25 is recommended):
 
$$\text{Torque (Lb. In.)} = \frac{\text{HP} \times 63025}{\text{RPM}} \times \text{SF}$$
  - Determine the "weak link" in the drive train, (i.e. chain, reducer, belt or shaft). Select an overload release torque that is below the "weak link's" maximum torque rating.
  - Physically measure the drive torque with a torque wrench and size accordingly.
- Determine the bore size(s) and keyway(s):
  - Shaft size at the clutch location determines the clutch bore.
  - Shaft size at the coupling location determines the coupling bore (if applicable).
- Choose the appropriate Model (S or F), based upon the drive layout and the application's requirements.
- Refer to the Basic Selection Chart for the appropriate clutch size.
- Refer to Part Numbering System to complete selection.

The Standard Model S is Boston Gear's basic low-cost unit on which various optional features can be added. The clutch mechanism is available in automatic or manual reset. Typically, a manual reset clutch is used where it will run disengaged for extended periods of time. The automatic reset is generally used in conjunction with a limit switch to shut the drive down. The Standard Model is typically used to replace shear pins and where access to the clutch is available. See page 19.

The Fully Automatic Model F includes all the features available in the Standard Model plus an automatic switch actuating mechanism, an automatic clutch mechanism and three mounting styles. The Model F is generally used where the unit is not easily accessible. This model is a complete overload clutch designed especially for production and packaging machinery. See page 27.

### Trig-O-Matic Model Feature Comparisons

ORC Series Model S	ORC Series Model F
Bi-directional	Bi-directional
Single Position	Single Position
Manual Clutch Reset	Automatic Clutch Reset
Automatic Clutch Reset	Automatic Clutch Reset
Clutch Types C, N, R, T	Clutch Types C, N, R, T
One Mounting Style	Three Mounting Styles
Limit Switch Pin	Fully Automatic
Limit Switch Plate Actuator	Limit Switch Plate Actuator
Additional Features: Torque Selector Dial Max. Torque Limit Stop Grease Pack & Relief Fittings	Additional Features: Torque Selector Dial Max. Torque Limit Stop Grease Pack & Relief Fittings Locking Collar Mounting
Optional: Pressure Lube Bearings Balancing Locking Collar Mounting	Optional: Balancing One-Directional Feature

### Basic Selection Chart

Standard Model S					Fully Automatic Model F				
Clutch Size	Max. Bore (Inch)*	Torque Code	Torque Range (Lb. In.)		Clutch Size	Max. Bore (Inch)*	Torque Code	Torque Range (Lb. In.)	
			Min.	Max.				Min.	Max.
1	0.8750	L	35	100	1	0.7500	L	70	140
		M	75	275			M	110	275
		H	200	400			H	260	400
2	1.1875	L	50	200	2	1.1250	L	100	200
		M	200	600			M	200	600
		H	400	1,000			H	400	1,000
3	1.8120	L	200	850	3	1.7500	L	200	850
		M	800	2,200			M	800	2,200
		H	1,200	3,000			H	1,200	3,000
4	2.3120	L	600	1,400	4	2.1250	L	600	1,400
		M	1,200	3,000			M	1,200	3,000
		H	2,850	5,000			H	2,850	5,000
5	3.0000	L	1,600	3,000	5	2.7500	L	1,600	3,000
		M	2,500	6,000			M	2,500	6,000
		H	4,000	10,000			H	4,000	10,000
6	3.9375	L	4,000	8,000	—	—	—	—	—
		M	7,500	14,000			—	—	—
		H	12,500	25,000			—	—	—

\*Larger bores may require flat keys (supplied with unit).

# Trig-O-Matic Overload Clutches ORC Series

## Standard Model S

### Operating Principles

The Standard Model S ORC Series Trig-O-Matic Overload Release Clutch consists of two basic components: the rotor and the housing assembly. The clutch rotor is keyed and secured to the drive shaft with a setscrew.

The housing assembly includes a drive pawl and a reset pawl which are pivoted within the clutch housing. The drive pawl is held engaged in the rotor notch by the combined pressure of the drive and reset springs as shown in Figure 1. The combined pressure of these two springs determines the maximum torque which is transmitted without overload. With the clutch mechanism in the engaged position shown in Figure 1, the rotor and housing are held together and the entire unit rotates with the drive shaft at the same speed.

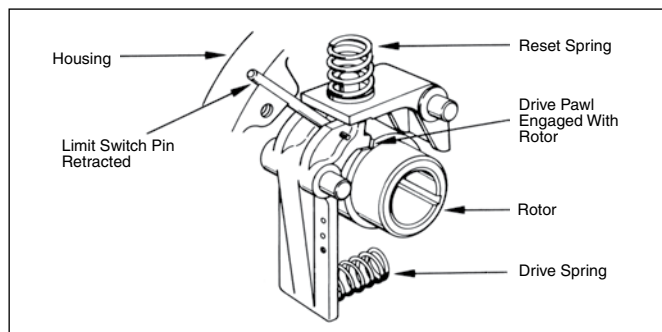

Figure 1 – Engaged

The Standard Model Trig-O-Matic is available in two clutch reset types: Manual and Automatic.

### Manual Reset

The instant an overload occurs, the pressure of the drive and reset springs is overcome by the extra force applied to them. The drive pawl is forced out of its engaged position from the rotor and as it pivots up, the reset pawl lifts and locks it out of contact with the rotor as shown in Figure 2. The clutch then rotates freely.

When the overload condition has been corrected, the clutch is reset by inserting a hexagon wrench in the reset screw and turning the screw clockwise until the reset pawl releases the drive pawl. When the drive pawl re-engages with the rotor, the reset screw must be backed out to its original stop position. This is essential to restore the torque to its original setting.

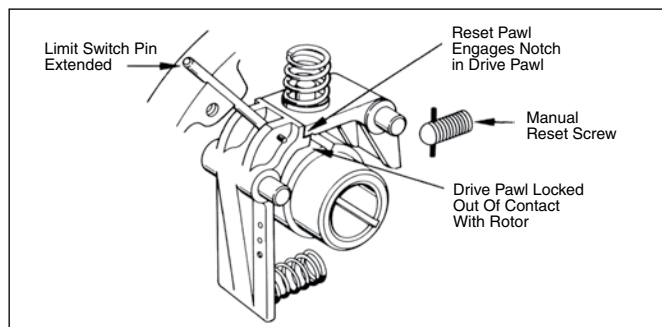

Figure 2  
Disengaged - Manual

### Fully Automatic or Semi-Automatic

The instant an overload occurs, the pressure of the drive and reset springs is overcome by the extra force applied to them. The drive pawl is forced out of its engaged position from the rotor. After one revolution the drive pawl will automatically return to its engaged position. If the overload is still present, it will not seat and will continue to rotate until overload has been removed. The drive should be stopped as soon as possible. After the overload condition has been corrected the drive must be “jogged” until the drive pawl engages with the rotor.

Note: Models “SB” and “SC” are semi-automatic because the actuating plate must be manually reset. See models F (page 27) or SA for fully automatic operation.

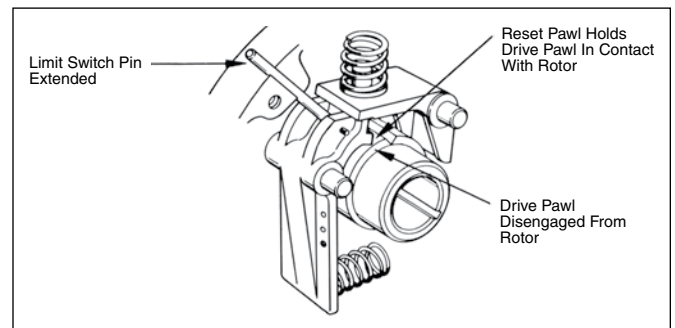

Figure 3  
Disengaged - Automatic

### Limit Switch Pin

A Limit Switch Pin is furnished as a standard item for model SA and SM to activate a limit switch that triggers the electrical controls. The travel of the Limit Switch Pin protruding radially from the clutch housing is controlled by the drive pawl motion upon disengagement. The Limit Switch Pin can only be effective if the housing continues to turn when an overload occurs and the rotor stops, (i.e., the housing is the driver and the rotor is the driven). The housing RPM must be considered to determine the time for the Limit Switch Pin to revolve around before contacting the limit switch.

The standard Limit Switch Pin extension is 1-inch, however, it can be made flush with the housing when engaged. If the Limit Switch Pin is not required, it can be omitted from the assembly with a “Z1” suffix.

If instantaneous operation of a limit switch is required or if the housing stops upon overload, see Page 25 for the Limit Switch Plate Actuator or the Model F on page 27. Units which include this device do not have the Limit Switch Pin.

# Trig-O-Matic Overload Clutches

## Torque Selector Dial

The torque selector dial shown in Figure 4 is a standard feature on all Standard Model S Trig-O Matic clutches. Each clutch is individually calibrated to specific torque values. The housing has two milled marks indicating minimum and maximum torque. In addition, these values are stamped on the housing adjacent to each mill mark. To adjust the torque, loosen the “lock screw”, turn the torque adjusting screw (stamped #9) until it is flush with the milled depth and the red scribed lines match the required output position. Additional marks can be indicated upon request.

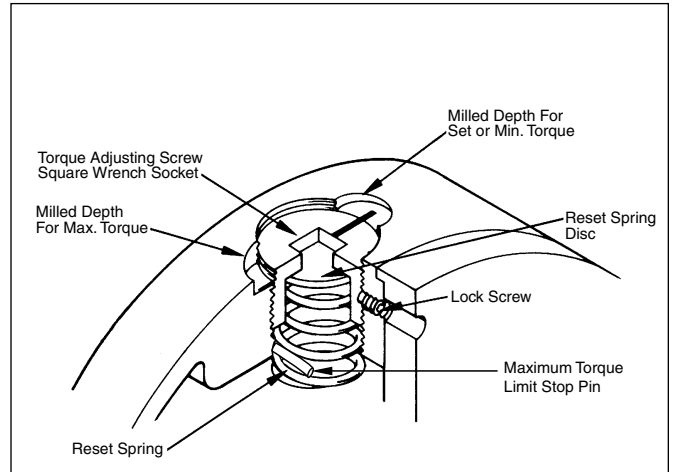

Figure 4

### Maximum Torque Limit Stop

A maximum torque limit stop is supplied to prevent clutch lock-up. In conjunction with a torque selector dial, the maximum value indicated by the deepest milled mark can not be exceeded.

### Grease Pack Fittings

Grease pack fittings are supplied countersunk into the clutch housing to pack the clutch cavity, preventing corrosion. This feature is especially suitable for outdoor or washdown service.

### ORC Model S Series Part Numbering System

<b>ORC</b>	<b>2</b>	<b>SA</b>	<b>C</b>	-	<b>L</b>	<b>P16</b>	-	<b>P20</b>	<b>XX</b>
Series	Size	Model	Type		Torque Range			Coupling Bore (Type C, N or R Only)	
Overload Release Clutch	1 2 3 4 5 6	SA = Standard Model, Fully Automatic Reset with Pin Actuator SB* = Standard Model, Semi-Automatic Reset with Plate Actuator SM = Standard Model, Manual Reset with Pin Actuator SP* = Standard Model, Manual Reset with Plate Actuator	T = Sprocket Mount C = Flexible Coupling N = Indexing Coupling R = Rigid Coupling		L = Light M = Medium H = Heavy 9 = Special Contact Boston Gear Engineering			P = Bored to Size (in 1/16") M = Metric Bored to Size (mm) (Leave Blank for Non-Coupled Units)	Special Options TX = Special Features Contact Boston Gear Engineering B1 = Ball Bearings for High Speed Applications F2 = Steel IT Paint and Food Grade Grease G1 = High Temperature Grease L1 = Pressure Lubed Bearings (Sizes 3-6 Only) S1 = Static Balance Z1 = Pin Removed on "SA" and "SM" Models Only
					Unit Bore				
					P = Bored to Size (in 1/16") M = Metric Bored to Size (mm)				

\*Dimensions shown on page 25

### How to Order — Standard Model S

When ordering an ORC Series Trig-O-Matic Overload Clutch, please include code letters for series, size, model, type, torque range, unit bore and coupling bore (if applicable). Not all combinations are possible.

#### Example:

Required Size 2 Trig-O-Matic Overload Clutch, Standard Model S, automatic reset with pin actuator, flexible coupling, light torque range, with a one inch unit bore and a one inch coupling bore:

ORC 2 SA C — L P16 — P20 (Only include second bore "P20" if clutch is a coupling style)

# Trig-O-Matic Overload Clutches ORC Series

## Model SA and SM

### Type T Sprocket, Sheave, Pulley Mounting

For additional dimensional information on Model SB and SP, see page 25.

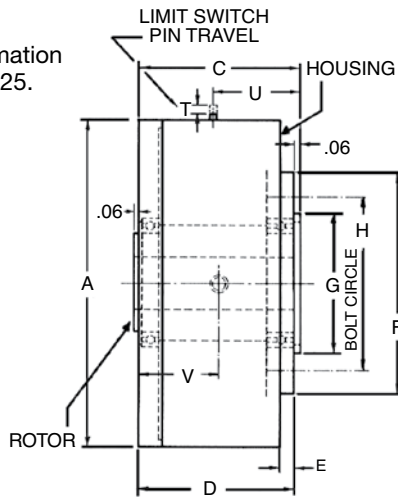

All Dimensions in Inches

Clutch Size	A	C	D	E	F	G +.000/-0.002	H Bolt Circle	T	U	V	Weight (Lbs.)
1	4.50	2.31	2.25	0.37	2.87	1.875	2.375	.13	1.28	1.03	6
2	6.00	2.75	2.69	0.43	3.68	2.250	3.000	.13	1.53	1.22	12
3	8.00	3.50	3.44	0.50	4.87	3.250	4.125	.13	1.94	1.56	26
4	10.00	4.47	4.41	0.68	6.12	3.203	5.000	.13	2.66	1.81	55
5	12.00	5.12	5.06	0.81	7.50	4.125	6.250	.13	3.00	2.12	100
6	16.00	6.25	6.19	1.06	10.00	6.000	8.750	.25	3.68	2.56	215

Refer to Page 21 for mounting hole patterns.

### Ratings

Clutch Size	Torque Range (Lb. In.)			Max. RPM*	WR <sup>2</sup> (Lb.-In. <sup>2</sup> )	
	L	M	H			
1	Min.	35	75	200	1,800	14
	Max.	100	275	400		
2	Min.	50	200	400	1,200	54
	Max.	200	600	1,000		
3	Min.	200	800	1,200	1,200	212
	Max.	850	2,200	3,000		
4	Min.	600	1,200	2,850	900	693
	Max.	1,400	3,000	5,000		
5	Min.	1,600	2,500	4,000	600	1,818
	Max.	3,000	6,000	10,000		
6	Min.	4,000	7,500	12,500	600	6,940
	Max.	8,000	14,000	25,000		

Clutches are shipped set for the minimum torque value of the selected range.

\*For speeds exceeding 75% of the maximum RPM, Ball Bearings and balancing are recommended.

Sprockets, gears, sheaves and pulleys can be mounted upon request.

Refer to Page 21 for sprocket sizes.

Refer to Page 19 for ordering information.

### Clutch Bores

Clutch Size	Bores (inch)		
	Min.	Max. (1)	Max. (2)
1	0.5000	0.7500	0.8750
2	0.6250	1.1250	1.1875
3	0.7500	1.7500	1.8125
4	1.1250	2.2500	2.3125
5	1.5000	2.7500	3.0000
6	2.0000	3.7500	3.9375

Refer to Page 96 for a complete list of bore codes.

- (1) Square Key
- (2) Flat Key

# Trig-O-Matic Overload Clutches ORC Series

## Model S and F Type T Mounting Hole Patterns

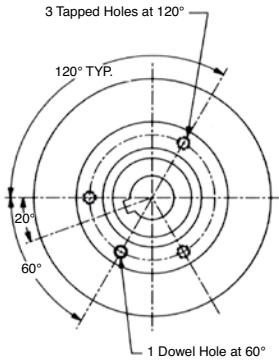

**Clutch Sizes 1 and 2**

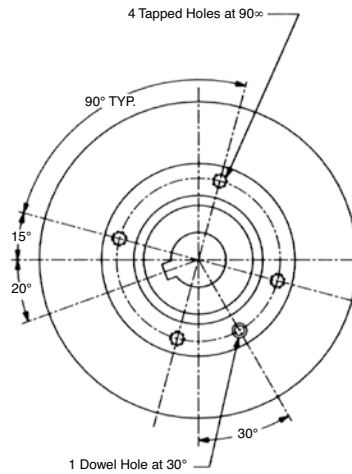

**Clutch Sizes 3 and 4**

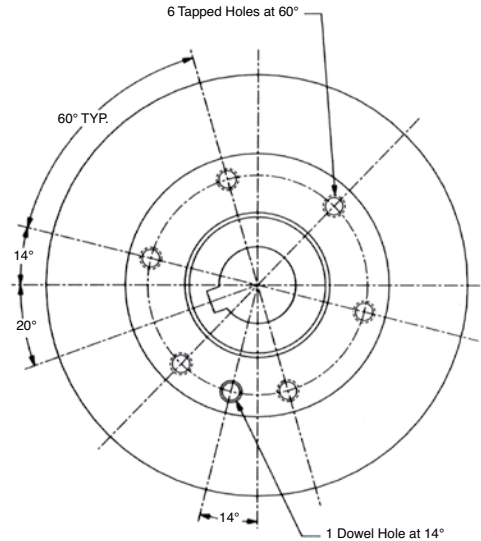

**Clutch sizes 5 and 6**

Clutch Size	Mounting Holes					
	Qty.	Thread Size	Tap Depth	Bolt Circle	Pilot Dia. +.000 -.002	Dowel Size
1	3	1/4-20	.50	2.375	1.875	.25
2	3	5/16-18	.50	3.000	2.250	.31
3	4	3/8-16	.62	4.125	3.250	.37
4	4	1/2-13	.87	5.000	3.203	.50
5	6	5/8-11	1.00	6.250	4.125	.62
6	6	5/8-11	1.00	8.750	6.000	.62

### Minimum Number of Teeth Adaptable to Type T Clutches

Clutch Size	Standard Chain Size and Pitch										
	#25 1/4 Pitch	#35 3/8 Pitch	#40 1/2 Pitch	#41 1/2 Pitch	#50 5/8 Pitch	#60 3/4 Pitch	#80 1 Pitch	#100 1-1/4 Pitch	#120 1-1/2 Pitch	#140 1-3/4 Pitch	#160 2 Pitch
1	40	28	22	22	18	Not Recommended					
2	54	36	28	28	22	19	Not Recommended				
3	45		34	36	28	25	19	Not Recommended			
4	42			45	36	30	23	19	Not Recommended		
5	Consult Factory				42	36	30	22	19	17	Not Recommended
6	Consult Factory					48	36	30	24	21	19

For smaller sprockets, consult Boston Gear Engineering at 800-816-5608.

# Trig-O-Matic Overload Clutches ORC Series

## Model SA and SM

### Type C Flexible Coupling

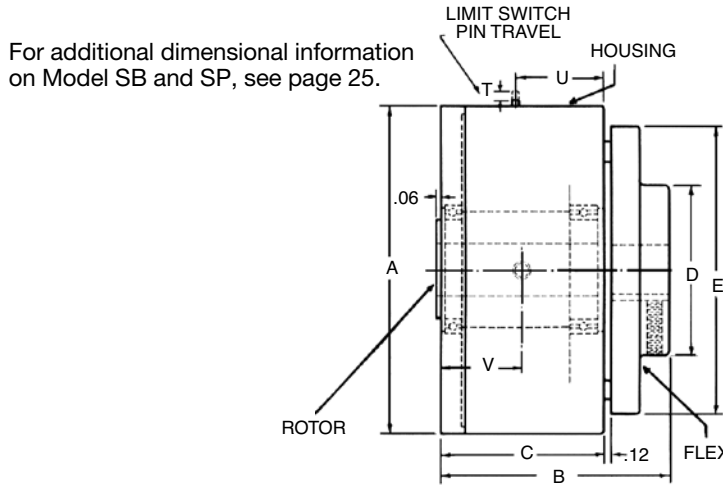

For additional dimensional information on Model SB and SP, see page 25.

All Dimensions in Inches

Clutch Size	A	B	C	D	E	U	T	V	Angular Misalignment*	Max. Parallel Offset*	Weight (Lbs.)
1	4.50	3.94	2.31	2.00	4.25	1.28	.13	1.03	< 1°	.012	10
2	6.00	4.62	2.75	2.56	5.25	1.53	.13	1.22	< 1°	.015	18
3	8.00	5.87	3.50	3.50	5.87	1.94	.13	1.56	< 1°	.016	39
4	10.00	7.71	4.47	4.87	9.12	2.66	.13	1.81	< 1°	.027	94
5	12.00	8.87	5.12	5.68	10.50	3.00	.13	2.12	< 1°	.031	163
6	16.00	11.12	6.25	7.63	13.25	3.68	.25	2.56	< 1°	.045	354

\*Parallel offset and angular misalignment are proportionally reduced if both are present

### Ratings

Clutch Size	Torque Range (Lb. In.)			Max. RPM*	WR <sup>2</sup> (Lb.-In. <sup>2</sup> )	
	L	M	H			
1	Min.	35	75	200	1,800	25
	Max.	100	275	400		
2	Min.	50	200	400	1,200	80
	Max.	200	600	1,000		
3	Min.	200	800	1,200	1,200	300
	Max.	850	2,200	3,000		
4	Min.	600	1,200	2,850	900	1,190
	Max.	1,400	3,000	5,000		
5	Min.	1,600	2,500	4,000	600	2,850
	Max.	3,000	6,000	10,000		
6	Min.	4,000	7,500	12,500	600	10,900
	Max.	8,000	14,000	25,000		

### Clutch and Coupling Bores

Clutch Size	Type	Bores (inch)		
		Min.	Max. (1)	Max. (2)
1	Clutch	0.5000	0.7500	0.8750
	Coupling	0.5000	1.5000	1.5625
2	Clutch	0.6250	1.1250	1.1875
	Coupling	0.6250	1.8125	1.9375
3	Clutch	0.7500	1.7500	1.8125
	Coupling	0.7500	2.5000	2.6250
4	Clutch	1.1250	2.2500	2.3125
	Coupling	1.1250	3.6875	3.8125
5	Clutch	1.5000	2.7500	3.0000
	Coupling	1.5000	4.2500	4.5000
6	Clutch	2.0000	3.7500	3.9375
	Coupling	2.0000	5.5000	5.7500

Refer to Page 96 for a complete list of bore codes.

(1) Square Key

(2) Flat Key

Clutches are shipped set for the minimum torque value of the selected range.

\*For speeds exceeding 75% of the maximum RPM, ball bearings and balancing are recommended.

Refer to Page 19 for ordering information.



# Trig-O-Matic Overload Clutches ORC Series

## Model SA and SM Type N Indexing Coupling

For additional dimensional information on Model SB and SP, see page 25.

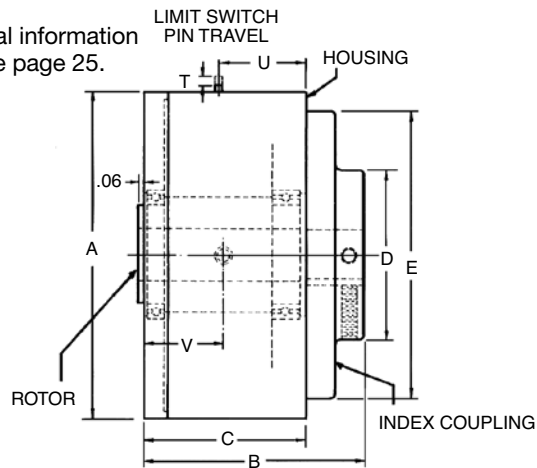

All Dimensions in Inches

Clutch Size	A	B	C	D	E	T	U	V	Weight (Lbs.)
1	4.50	3.81	2.31	2.00	4.25	.13	1.28	1.03	10
2	6.00	4.44	2.75	2.56	5.25	.13	1.53	1.22	18
3	8.00	5.75	3.50	3.00	7.00	.13	1.94	1.56	39
4	10.00	7.59	4.47	4.87	9.12	.13	2.66	1.81	94
5	12.00	8.68	5.12	5.68	10.50	.13	3.00	2.12	163
6	16.00	10.94	6.25	8.18	13.25	.25	3.68	2.56	354

### Ratings

Clutch Size	Torque Range (Lb. In.)			Max. RPM*	WR <sup>2</sup> (Lb.-In. <sup>2</sup> )
	L	M	H		
1	Min.	35	75	1,800	25
	Max.	100	275		
2	Min.	50	200	1,200	80
	Max.	200	600		
3	Min.	200	800	1,200	300
	Max.	850	2,200		
4	Min.	600	1,200	900	1,190
	Max.	1,400	3,000		
5	Min.	1,600	2,500	600	2,850
	Max.	3,000	6,000		
6	Min.	4,000	7,500	600	10,900
	Max.	8,000	14,000		

### Clutch and Coupling Bores

Clutch Size	Type	Bores (inch)		
		Min.	Max. (1)	Max. (2)
1	Clutch	0.5000	0.7500	0.8750
	Coupling	0.5000	1.5000	1.5625
2	Clutch	0.6250	1.1250	1.1875
	Coupling	0.6250	1.8125	1.9375
3	Clutch	0.7500	1.7500	1.8125
	Coupling	0.7500	1.7500	1.8125
4	Clutch	1.1250	2.2500	2.3125
	Coupling	1.1250	3.6875	3.8125
5	Clutch	1.5000	2.7500	3.0000
	Coupling	1.5000	4.2500	4.5000
6	Clutch	2.0000	3.7500	3.9375
	Coupling	2.0000	5.5000	5.7500

Clutches are shipped set for the minimum torque value of the selected range.

\*For speeds exceeding 75% of the maximum RPM, ball bearings and balancing are recommended.

Refer to Page 96 for a complete list of bore codes.

(1) Square Key

(2) Flat Key

Refer to Page 19 for ordering information.

# Trig-O-Matic Overload Clutches ORC Series

## Model SA and SM

### Type R Rigid Coupling

For additional dimensional information on Model SB and SP, see page 25.

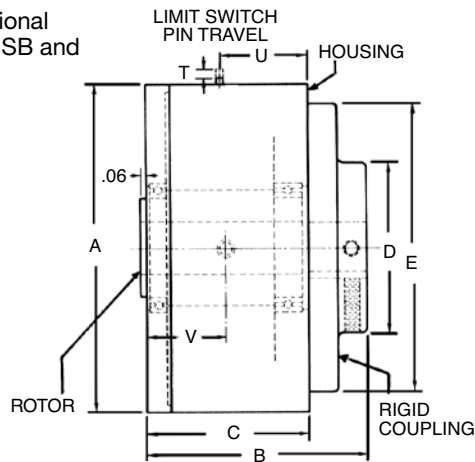

All Dimensions in Inches

Clutch Size	A	B	C	D	E	T	U	V	Weight (Lbs.)
1	4.50	3.81	2.31	2.00	4.25	.13	1.28	1.03	10
2	6.00	4.44	2.75	2.56	5.25	.13	1.53	1.22	18
3	8.00	5.75	3.50	3.00	7.00	.13	1.94	1.56	39
4	10.00	7.59	4.47	4.87	9.12	.13	2.66	1.81	94
5	12.00	8.68	5.12	5.68	10.50	.13	3.00	2.12	163
6	16.00	10.94	6.25	8.18	13.25	.25	3.68	2.56	354

### Ratings

Clutch Size	Torque Range (Lb. In.)			Max. RPM*	WR <sup>2</sup> (Lb.-In. <sup>2</sup> )	
	L	M	H			
1	Min.	35	75	200	1,800	25
	Max.	100	275	400		
2	Min.	50	200	400	1,200	80
	Max.	200	600	1,000		
3	Min.	200	800	1,200	1,200	300
	Max.	850	2,200	3,000		
4	Min.	600	1,200	2,850	900	1,190
	Max.	1,400	3,000	5,000		
5	Min.	1,600	2,500	4,000	600	2,850
	Max.	3,000	6,000	10,000		
6	Min.	4,000	7,500	12,500	600	10,900
	Max.	8,000	14,000	25,000		

Clutches are shipped set for the minimum torque value of the selected range.

\*For speeds exceeding 75% of the maximum RPM, ball bearings and balancing are recommended.

### Clutch and Coupling Bores

Clutch Size	Type	Bores (inch)		
		Min.	Max. (1)	Max. (2)
1	Clutch	0.5000	0.7500	0.8750
	Coupling	0.5000	1.5000	1.5625
2	Clutch	0.6250	1.1250	1.1875
	Coupling	0.6250	1.8125	1.9375
3	Clutch	0.7500	1.7500	1.8125
	Coupling	0.7500	1.7500	1.8125
4	Clutch	1.1250	2.2500	2.3125
	Coupling	1.1250	3.6875	3.8125
5	Clutch	1.5000	2.7500	3.0000
	Coupling	1.5000	4.2500	4.5000
6	Clutch	2.0000	3.7500	3.9375
	Coupling	2.0000	5.5000	5.7500

Refer to Page 96 for a complete list of bore codes.

(1) Square Key

(2) Flat Key

Refer to Page 19 for ordering information.

# Trig-O-Matic Overload Clutches ORC Series

## Model S Options

### Semi-Automatic Model SB and SP Proximity Plates

#### Limit Switch Plate Actuator, Models SB/SC and SP/SS

Available for all types, the Standard Model S Trig-O-Matic Limit Switch Plate Actuator provides instant operation of a limit switch to shut down the drive or to actuate an alarm should an overload occur. When an overload occurs, the drive pawl motion releases the actuating plate and it trips a limit switch. The total motion of the plate is .31 of an inch (See Figure 5).

After the overload has been cleared and the clutch is re-engaged, the actuating plate is manually returned to its normal operating position by applying equally spaced pressure to the surface of the plate.

A limit switch should be able to operate within the plate travel of .31 of an inch. Wire the switch in parallel with a jog circuit so that the drive can then be indexed to the start/run circuit.

#### Balancing

Static balancing is available for applications that exceed 50% of the catalog maximum RPM. Always consult the factory with complete drive details and layout for these high speed applications. Ball bearings are recommended for speeds exceeding 75% of maximum rating and is available with a "B1" suffix.

#### Custom Variations

Sprockets, sheaves, pulleys and gears can be supplied and mounted to the clutch. Contact Boston Gear Engineering at 800-816-5608.

Bores and keyways (i.e. metric, non-standard)

#### Special Finishes

All clutches are supplied with a standard lacquer finish. Special coatings, finishes, or paints are also available upon request. Adding suffix - F2 to the model number will provide Steel-It paint and food grade grease.

#### Pressure Lube Model

Pressure lube bronze bearings are preferred for use in harsh environments such as wastewater treatment plants or installations requiring wash-down service. Grease fittings are furnished to permit periodic lubrication to the inside diameter of the sleeve bearings.

The Pressure Lube Model Trig-O-Matic is available with either the Limit Switch Pin or the Limit Switch Plate Actuator and is available by adding an L1 suffix to the model number. Available on sizes 3, 4, 5, and 6 only.

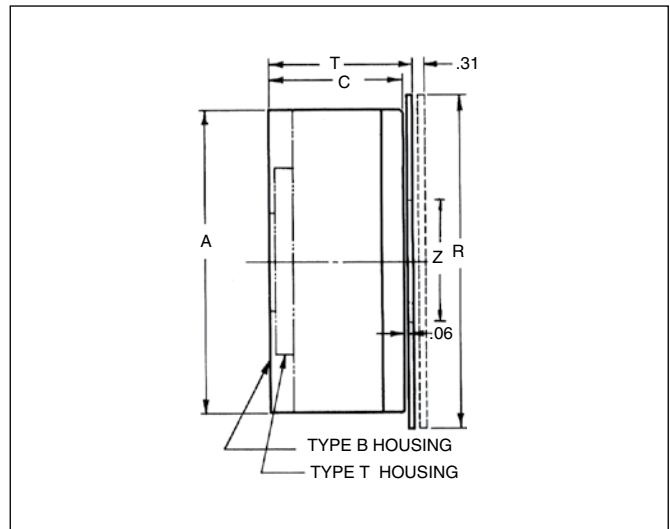

Figure 5

#### All Dimensions in Inches

Clutch Size	A	C	R*	T	Z
1	4.50	2.31	5.50	2.53	2.00
2	6.00	2.75	7.00	2.97	3.25
3	8.00	3.50	9.50	3.72	4.50
4	10.00	4.47	11.50	4.69	5.75
5	12.00	5.12	13.50	5.34	5.50
6	16.00	6.25	17.50	6.50	7.25

\*The R dimension may be reduced to the A dimension if required, specify SC for a semi-automatic clutch with a reduced plate and SS for a manual reset with a reduced diameter plate. Example: ORC2SCTMP16

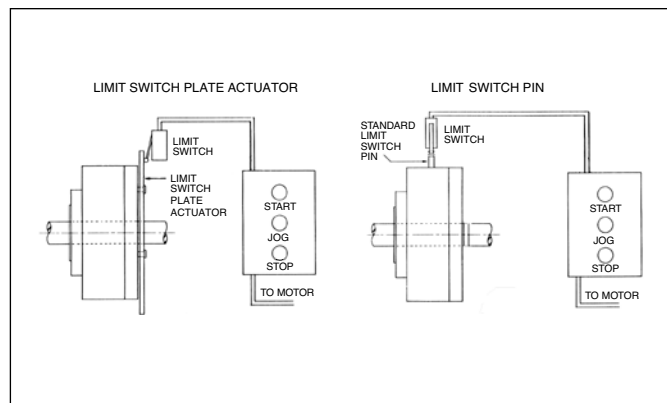

Figure 6

Figure 6 illustrates two methods of utilizing a single limit switch to detect an overload condition.

# Trig-O-Matic Overload Clutches ORC Series

## Fully Automatic Model F

### Operating Principles

The Fully Automatic Model F Trig-O-Matic Overload Release Clutch consists of three basic components: the rotor, the housing assembly and the automatic limit switch actuating plate assembly. The clutch rotor is keyed and secured with a locking collar (Models FJ and FG) or, with a setscrew (Model FR).

The housing assembly includes a drive pawl and a reset pawl which are pivoted within the clutch housing. The drive pawl is held in its engaged position by the combined pressure of the drive and reset springs as shown in Figure 7. The combined pressure of these two springs determines the maximum torque which is transmitted without overload. With the clutch mechanism in the engaged position, the rotor and housing are held together and the entire unit rotates with the drive shaft at the same speed.

When an overload occurs, the rotor rotates from its normal position within the housing. At this instant, the combined pressure of the drive and reset springs is overcome by the extra force applied to them and the drive pawl disengages from the rotor. The pressure applied by both springs holds the drive pawl in contact with the rotor, (See Figure 8). After one revolution, the drive pawl will automatically re-engage.

The automatic limit switch actuating plate assembly is incorporated to provide a means by which an external limit switch can be actuated to stop the drive.

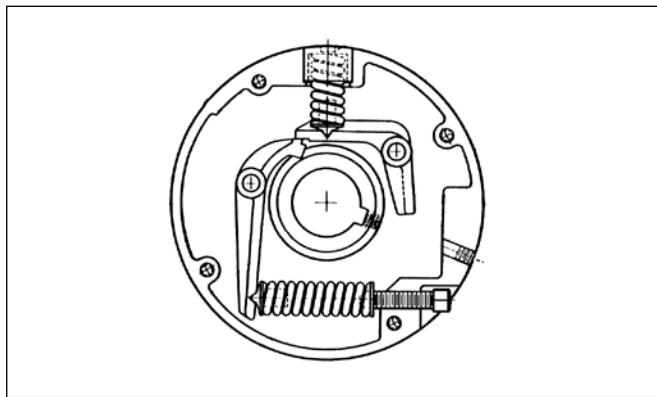

Figure 7 – Engaged

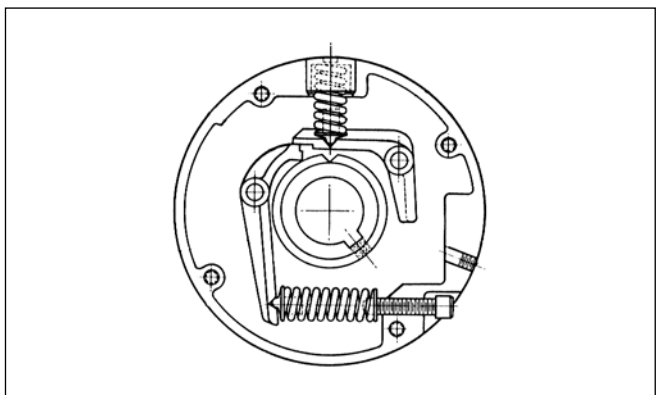

Figure 8 – Disengaged

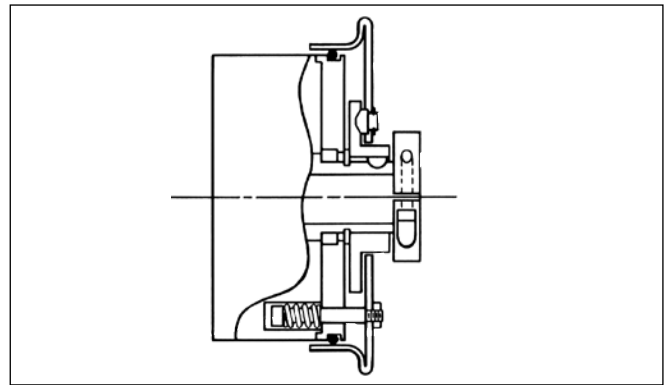

Figure 9 – Switch Actuating Plate Assembly

After the overload condition has been corrected, the drive must be “jogged” until the drive pawl engages with the rotor. The clutch has now reindexed itself to its original position.

The fully automatic Model F includes, as standard, a limit switch actuating plate assembly. Upon overload, the rotor is released from its engaged position within the housing. The resulting rotation causes the cam plate, which is keyed to the rotor, to exert pressure on the lift-out buttons forcing them to move the actuating plate axially away from the clutch housing, (See Figure 9).

When the clutch re-engages, the actuating plate is automatically returned to its original position by the return spring’s pressure on the return pins.

The actuating plate can only retract completely to its original position upon re-engagement of the drive pawl with the rotor.

### Locking Collar Mounting

Three clutch models are available for mounting. Models FJ and FG incorporate a locking collar design which provides a positive clamp on the key and shaft. Model FR uses a standard setscrew mounting arrangement, (See Figure 10).

<p><b>Model FJ</b></p> 	<p>Model FJ is used where full shaft length is available.</p> <p>Collar Mounted</p>
<p><b>Model FG</b></p> 	<p>Model FG is used where shaft length is limited.</p> <p>Collar Mounted</p>
<p><b>Model FR</b></p> 	<p>Model FR is used where overall space is limited.</p> <p>Set Screw Mounted</p>

Figure 10 – Model F Styles

# Trig-O-Matic Overload Clutches ORC Series

## Fully Automatic Model F

### Torque Selector Dial

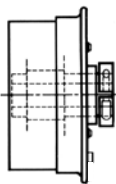
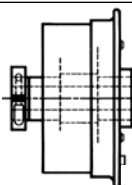
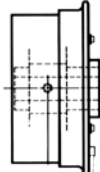
The torque selector dial shown in Figure 11 is a standard feature on all Fully Automatic Model F Trig-O-Matic clutches. Each clutch is individually calibrated to specific torque values. The housing has two milled marks indicating minimum and maximum torque. In addition, these values are stamped on the housing adjacent to each mill mark. To adjust the torque, loosen the “lock screw”, turn the torque adjusting screw (stamped #9) until it is flush with the milled depth and the red scribed lines match the required output position. Additional marks can be indicated upon request.

### Maximum Torque Limit Stop

A maximum torque limit stop is supplied to prevent clutch lock-up. In conjunction with a torque selector dial, the maximum value indicated by the deepest milled mark can not be exceeded.

### Grease Pack Fittings

Grease pack and relief fittings are supplied countersunk into the clutch housing to pack the clutch cavity, preventing corrosion. This feature is especially suitable for outdoor or washdown service.

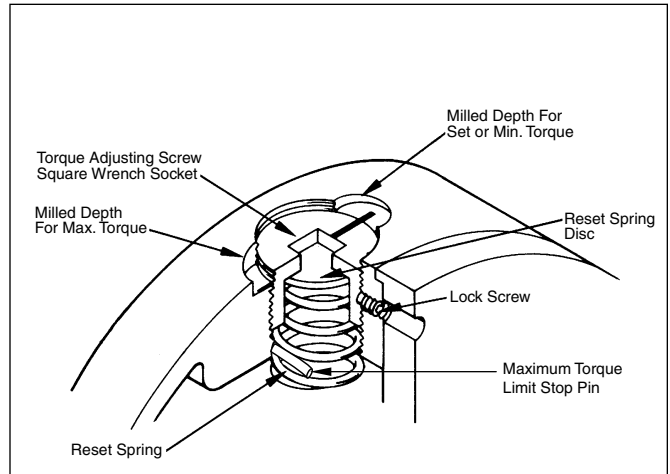

Figure 11

### ORC Model F Series Part Numbering System

<b>ORC</b>	<b>2</b>	<b>FG</b>	<b>C</b>	-	<b>L</b>	<b>P16</b>	-	<b>P20</b>	<b>XX</b>
<b>Series</b> Overload Release Clutch	<b>Size</b> 1 2 3 4 5	<b>Model</b> FJ = Model F, Full Available Shaft Length FG = Model F, Limited Available Shaft Length FR = Model F, Overall Limited Space	<b>Type</b> T = Sprocket Mount C = Flexible Coupling N = Indexing Coupling R = Rigid Coupling		<b>Torque Range</b> L = Light M = Medium H = Heavy 9 = Special Contact Boston Gear Engineering	<b>Unit Bore</b> P = Bored to Size (in 1/16") M = Metric Bored to Size (mm)		<b>Coupling Bore (Type C, N or R Only)</b> P = Bored to Size (in 1/16") M = Metric Bored to Size (mm) (Leave Blank for Non-Coupled Units)	<b>Special Options</b> TX = Special Features Contact Boston Gear Engineering B1 = Ball Bearings for High Speed Applications F2 = Steel IT Paint and Food Grade Grease G1 = High Temperature Grease

### How to Order — Standard Model F

When ordering an ORC Series Trig-O-Matic Overload Clutch, please include code letters for series, size, model, type, torque range, unit bore and coupling bore (if applicable). Not all combinations are possible.

#### Example:

Required Size 2 Trig-O-Matic Overload Clutch, Model F automatic reset, limited available shaft length, flexible coupling, light torque range, with a one inch unit bore and a one inch coupling bore:

ORC 2 FG C — L P16 — P20 (Only include second bore “P20” if clutch is a coupling style)

# Trig-O-Matic Overload Clutches ORC Series

## Model FJ, FG, and FR

### Type T Sprocket, Sheave, Pulley Mounting

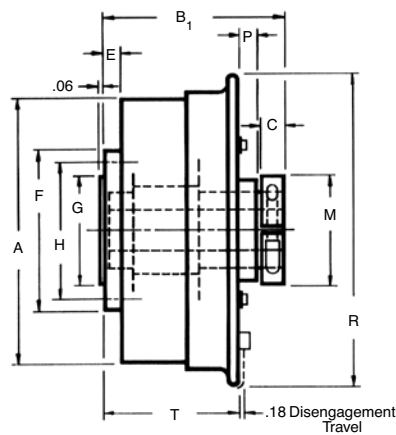

**Model FJ**

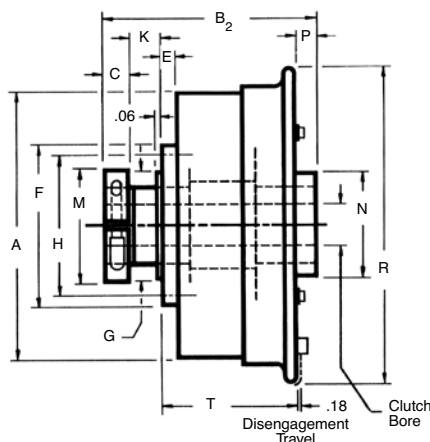

**Model FG**

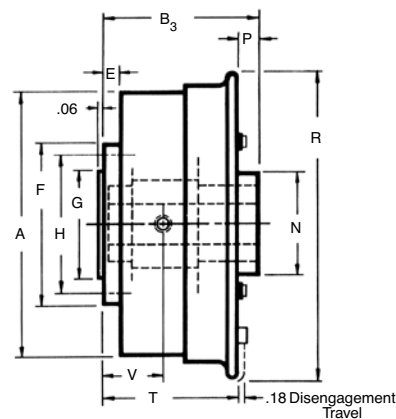

**Model FR**

#### All Dimensions in Inches

Clutch Size	A	B <sub>1</sub>	B <sub>2</sub>	B <sub>3</sub>	C	E	F	G +.000/-002	H Bolt Circle	K	M	N	P	R	T	V	Weight (Lbs.)
1	4.50	3.72	4.49	3.20	.50	.37	2.87	1.875	2.375	0.78	1.87	1.56	.38	5.50	2.83	1.22	7
2	6.00	4.22	4.96	3.66	.56	.43	3.68	2.250	3.000	0.74	2.37	2.25	.38	7.50	3.28	1.47	14
3	8.00	5.46	6.38	4.66	.75	.50	4.87	3.250	4.125	0.97	3.25	3.00	.59	9.50	4.08	1.88	30
4	10.00	6.79	7.50	5.94	.87	.68	6.12	3.203	5.000	0.72	4.25	4.00	.82	11.50	5.12	2.60	66
5	12.00	7.76	9.32	6.70	.87	.81	7.50	4.125	6.250	1.75	5.00	5.25	.86	14.00	5.85	2.93	123

Sprockets, sheaves, pulleys, and gears can be mounted upon request.  
Refer to Page 29 for maximum sprocket sizes and mounting hole patterns.

#### Ratings

Clutch Size	Torque Range (Lb. In.)			Max. RPM	WR <sup>2</sup> (Lb.-In. <sup>2</sup> )
	L	M	H		
1	Min.	70	110	1400	18
	Max.	140	275		
2	Min.	100	200	1000	65
	Max.	200	600		
3	Min.	200	800	1000	238
	Max.	850	2,200		
4	Min.	600	1,200	700	815
	Max.	1,400	3,000		
5	Min.	1,600	2,500	500	2,170
	Max.	3,000	10,000		

#### Clutch Bores

Clutch Size	Bores (inch)		
	Min.	Max. (1)	Max. (2)
1	0.5000	0.7500	—
2	0.6250	1.0000	1.1250
3	0.7500	1.6250	1.7500
4	1.1250	2.0000	2.2500
5	1.5000	2.6250	2.7500

Refer to Page 96 for a complete list of bore codes.

- (1) Square Key
- (2) Flat Key

Clutches are shipped set for the minimum torque value of the selected range.

Refer to Page 27 for ordering information.

# Trig-O-Matic Overload Clutches ORC Series

## Model S and F Type T Mounting Hole Patterns

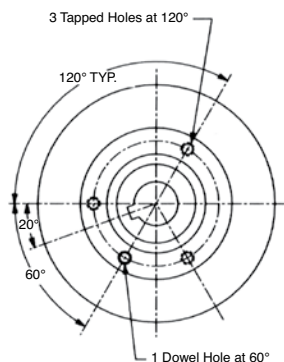

Clutch Sizes 1 and 2

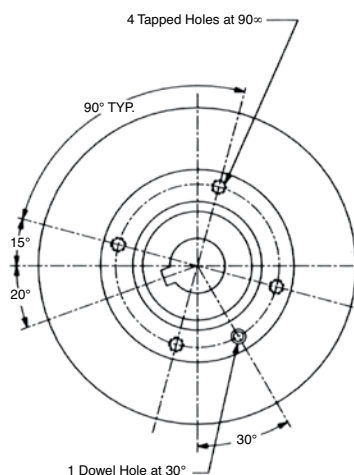

Clutch Sizes 3 and 4

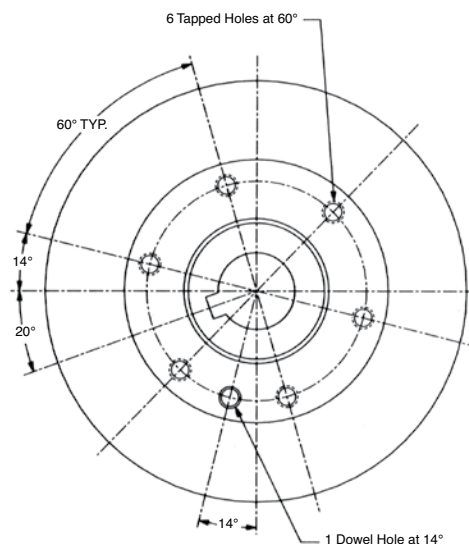

Clutch Sizes 5 and 6

Clutch Size	Mounting Holes					
	Qty.	Thread Size	Tap Depth	Bolt Circle	Pilot Dia. +.000 - .002	Dowel Size
1	3	1/4-20	.50	2.375	1.875	.25
2	3	5/16-18	.50	3.000	2.250	.31
3	4	3/8-16	.62	4.125	3.250	.37
4	4	1/2-13	.87	5.000	3.203	.50
5	6	5/8-11	1.00	6.250	4.125	.62
6	6	5/8-11	1.00	8.750	6.000	.62

### Minimum Number of Teeth Adaptable to Type T Clutches

Clutch Size	Standard Chain Size and Pitch										
	#25 1/4 Pitch	#35 3/8 Pitch	#40 1/2 Pitch	#41 1/2 Pitch	#50 5/8 Pitch	#60 3/4 Pitch	#80 1 Pitch	#100 1-1/4 Pitch	#120 1-1/2 Pitch	#140 1-3/4 Pitch	#160 2 Pitch
1	40	28	22	22	18	Not Recommended					
2	54	36	28	28	22	19	Not Recommended				
3	45		34	36	28	25	19	Not Recommended			
4	42			45	36	30	23	19	Not Recommended		
5	Consult Factory				42	36	30	22	19	17	Not Recommended
6	Consult Factory					48	36	30	24	21	19

For smaller sprockets, consult Boston Gear Engineering at 800-816-5608.

# Trig-O-Matic Overload Clutches ORC Series

## Model FJ and FR

### Type C Flexible Coupling

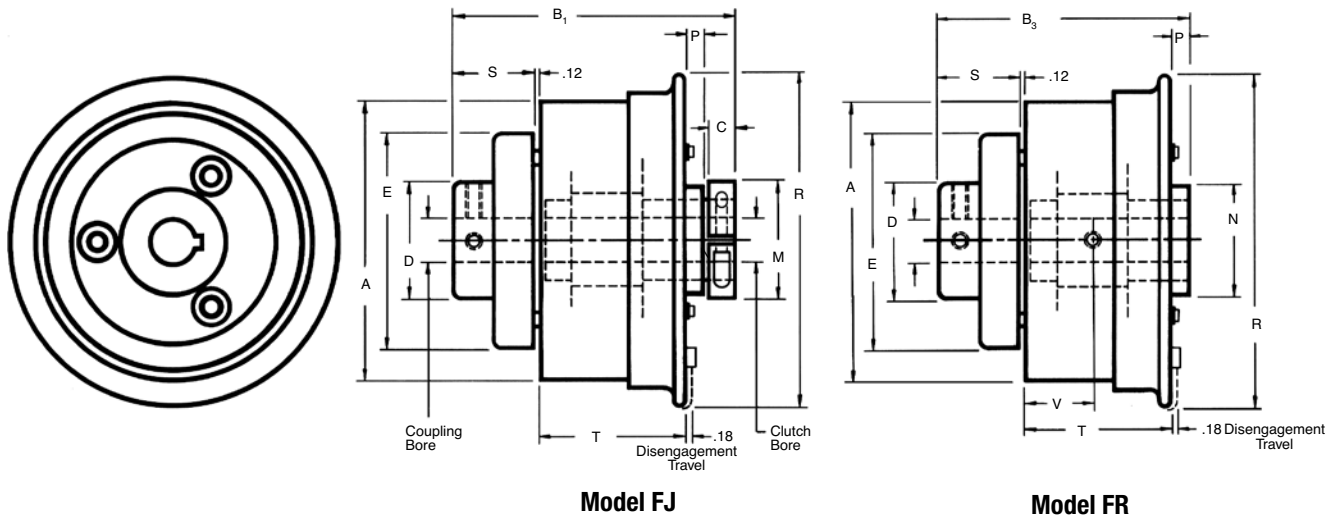

All Dimensions in Inches

Clutch Size	A	B <sub>1</sub>	B <sub>3</sub>	C	D	E	M	N	P	R	S	T	V	Angular Misalignment*	Max. Parallel Offset*	Weight (Lbs.)
1	4.50	5.41	4.89	.50	2.00	4.25	1.87	1.56	.38	5.50	1.50	2.89	1.28	< 1°	.012	10
2	6.00	6.15	5.59	.56	2.56	5.25	2.37	2.25	.38	7.50	1.75	3.34	1.53	< 1°	.015	20
3	8.00	7.89	7.09	.75	3.50	5.87	3.25	3.00	.59	9.50	2.25	4.14	1.93	< 1°	.016	42
4	10.00	10.09	9.23	.87	4.87	9.12	4.25	4.00	.82	11.50	3.12	5.18	2.66	< 1°	.027	103
5	12.00	11.57	10.51	.87	5.68	10.50	5.00	5.25	.86	14.00	3.62	5.91	3.00	< 1°	.031	180

\*Parallel offset and angular misalignment proportionately reduced if both are present.

### Ratings

Clutch Size	Torque Range (Lb. In.)			Max. RPM	WR <sup>2</sup> (Lb.-In. <sup>2</sup> )	
	L	M	H			
1	Min.	70	110	260	1400	26
	Max.	140	275	400		
2	Min.	100	200	400	1000	89
	Max.	200	600	1,000		
3	Min.	200	800	1,200	1000	327
	Max.	850	2,200	3,000		
4	Min.	600	1,200	2,850	700	1,270
	Max.	1,400	3,000	5,000		
5	Min.	1,600	2,500	4,000	500	3,160
	Max.	3,000	6,000	10,000		

Clutches are shipped set for the minimum torque value of the selected range.

### Clutch and Coupling Bores

Clutch Size	Type	Bores (inch)		
		Min.	Max. (1)	Max. (2)
1	Clutch	0.5000	0.7500	—
	Coupling	0.5000	1.5000	1.5625
2	Clutch	0.6250	1.0000	1.1250
	Coupling	0.6250	1.8125	1.9375
3	Clutch	0.7500	1.6250	1.7500
	Coupling	0.7500	2.5000	2.6250
4	Clutch	1.1250	2.0000	2.2500
	Coupling	1.1250	3.6875	3.8125
5	Clutch	1.5000	2.6250	2.7500
	Coupling	1.5000	4.2500	4.5000

Refer to Page 96 for a complete list of bore codes.

- (1) Square Key
- (2) Flat Key

Refer to Page 27 for ordering information.



# Trig-O-Matic Overload Clutches ORC Series

## Model FJ and FR Type N Indexing Coupling

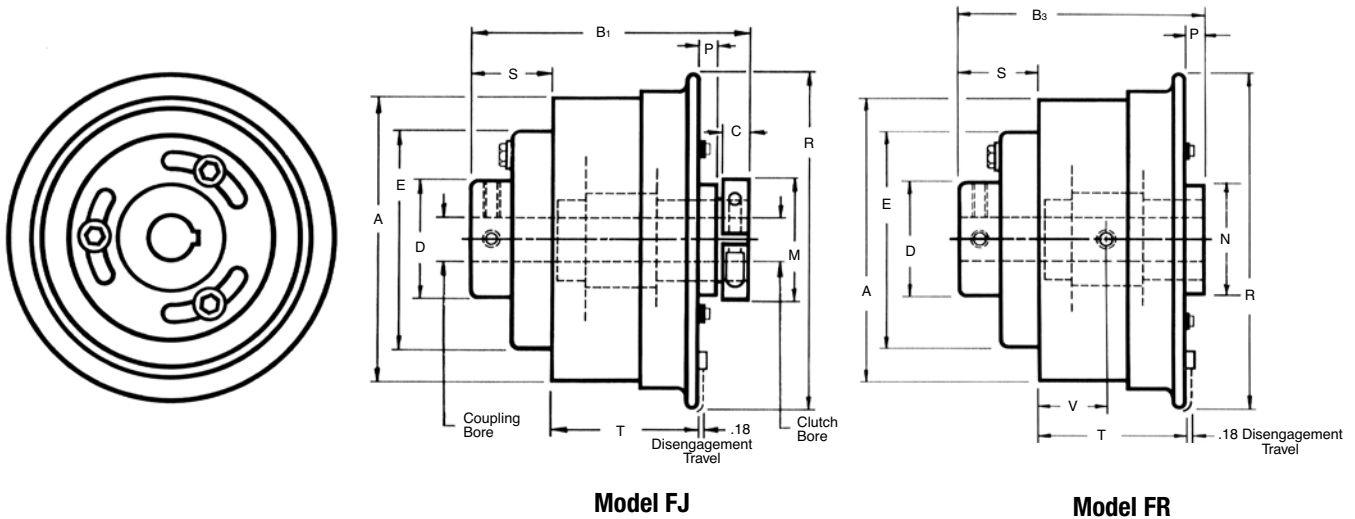

### All Dimensions in Inches

Clutch Size	A	B <sub>1</sub>	B <sub>3</sub>	C	D	E	M	N	P	R	S	T	V	Weight (Lbs.)
1	4.50	5.28	4.76	.50	2.00	4.25	1.87	1.56	.38	5.50	1.50	2.89	1.28	10
2	6.00	5.96	5.41	.56	2.56	5.25	2.37	2.25	.38	7.50	1.69	3.34	1.53	20
3	8.00	7.77	6.97	.75	3.00	7.00	3.25	3.00	.59	9.50	2.25	4.14	1.93	42
4	10.00	9.97	9.12	.87	4.87	9.12	4.25	4.00	.82	11.50	3.12	5.18	2.66	103
5	12.00	11.44	10.38	.87	5.68	10.50	5.00	5.25	.86	14.00	3.62	5.91	3.00	180

### Ratings

Clutch Size	Torque Range (Lb. In.)			Max. RPM	WR <sup>2</sup> (Lb.-In. <sup>2</sup> )
	L	M	H		
1	Min.	70	110	1400	26
	Max.	140	275		
2	Min.	100	200	1000	89
	Max.	200	600		
3	Min.	200	800	1000	327
	Max.	850	2,200		
4	Min.	600	1,200	700	1,270
	Max.	1,400	3,000		
5	Min.	1,600	2,500	500	3,160
	Max.	3,000	6,000		

Clutches are shipped set for the minimum torque value of the selected range.

### Clutch and Coupling Bores

Clutch Size	Type	Bores (inch)		
		Min.	Max. (1)	Max. (2)
1	Clutch	0.5000	0.7500	-
	Coupling	0.5000	1.5000	1.5625
2	Clutch	0.6250	1.0000	1.1250
	Coupling	0.6250	1.8125	1.9375
3	Clutch	0.7500	1.6250	1.7500
	Coupling	0.7500	1.7500	1.8125
4	Clutch	1.1250	2.0000	2.2500
	Coupling	1.1250	3.6875	3.8125
5	Clutch	1.5000	2.6250	2.7500
	Coupling	1.5000	4.2500	4.5000

Refer to Page 96 for a complete list of bore codes.  
(1) Square Key  
(2) Flat Key

Refer to Page 27 for ordering information.

# Trig-O-Matic Overload Clutches ORC Series

## Model FJ and FR

### Type R Rigid Coupling

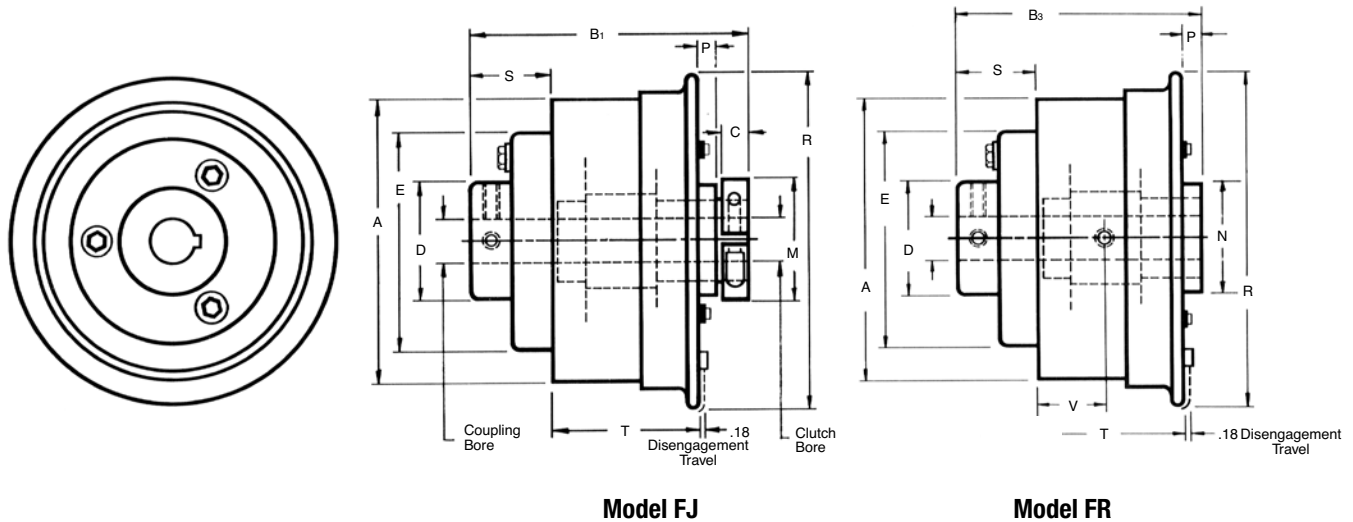

Model FJ

Model FR

#### All Dimensions in Inches

Clutch Size	A	B <sub>1</sub>	B <sub>3</sub>	C	D	E	M	N	P	R	S	T	V	Weight (Lbs.)
1	4.50	5.28	4.76	.50	2.00	4.25	1.87	1.56	.38	5.50	1.50	2.89	1.28	10
2	6.00	5.96	5.41	.56	2.56	5.25	2.37	2.25	.38	7.50	1.69	3.34	1.53	20
3	8.00	7.77	6.97	.75	3.00	7.00	3.25	3.00	.59	9.50	2.25	4.14	1.93	42
4	10.00	9.97	9.12	.87	4.87	9.12	4.25	4.00	.82	11.50	3.12	5.18	2.66	103
5	12.00	11.44	10.38	.87	5.68	10.50	5.00	5.25	.86	14.00	3.62	5.91	3.00	180

#### Ratings

Clutch Size	Torque Range (Lb. In.)			Max. RPM	WR <sup>2</sup> (Lb.-In. <sup>2</sup> )	
	L	M	H			
1	Min.	70	110	260	1400	26
	Max.	140	275	400		
2	Min.	100	200	400	1000	89
	Max.	200	600	1,000		
3	Min.	200	800	1,200	1000	327
	Max.	850	2,200	3,000		
4	Min.	600	1,200	2,850	700	1,270
	Max.	1,400	3,000	5,000		
5	Min.	1,600	2,500	4,000	500	3,160
	Max.	3,000	6,000	10,000		

Clutches are shipped set for the minimum torque value of the selected range.

#### Clutch and Coupling Bores

Clutch Size	Type	Bores (inch)		
		Min.	Max. (1)	Max. (2)
1	Clutch	0.5000	0.7500	-
	Coupling	0.5000	1.5000	1.5625
2	Clutch	0.6250	1.0000	1.1250
	Coupling	0.6250	1.8125	1.9375
3	Clutch	0.7500	1.6250	1.7500
	Coupling	0.7500	1.7500	1.8125
4	Clutch	1.1250	2.0000	2.2500
	Coupling	1.1250	3.6875	3.8125
5	Clutch	1.5000	2.6250	2.7500
	Coupling	1.5000	4.2500	4.5000

Refer to Page 96 for a complete list of bore codes.

- (1) Square Key
- (2) Flat Key

Refer to Page 27 for ordering information.

# Trig-O-Matic Overload Clutches ORC Series

## Fully Automatic Model F Options

### One-Direction Option

For applications with oscillating torque loads, a one-directional clutch is available to prevent needless disengagement of the clutch due to back-loading conditions.

The unique rotor/drive pawl configuration permits the clutch to disengage in the normal running direction in the event of an overload. It back stops any load in the opposite direction and is virtually a solid connection when driven in the opposite direction (see Figure 12).

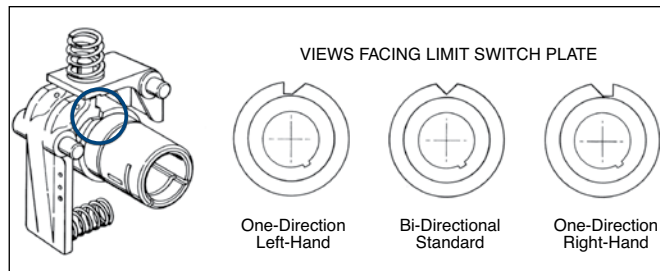

Figure 12

To select either the RIGHT-HAND or LEFT-HAND configuration:

- Determine the normal direction of rotation facing either
  - the limit switch plate, or
  - the housing
- Determine whether the input is driving through either
  - the rotor, or
  - the housing
- With this information, select the correct configuration from the chart below.

Clockwise Running Rotation Facing Limit Switch Plate	
Rotor Driving (input) Right-Hand Clutch	Housing Driving (input) Left-Hand Clutch
Clockwise Running Rotation Facing Housing	
Rotor Driving (input) Left-Hand Clutch	Housing Driving (input) Right-Hand Clutch
Counter Clockwise Running Rotation Facing Limit Switch Plate	
Rotor Driving (input) Left-Hand Clutch	Housing Driving (input) Right-Hand Clutch
Counter Clockwise Running Rotation Facing Housing	
Rotor Driving (input) Right-Hand Clutch	Housing Driving (input) Left-Hand Clutch

### Custom Variations

Sprockets, sheaves, pulleys and gears can be supplied and mounted to the clutch.

See page 21 or contact Boston Gear Engineering at 800-816-5608 for additional information.

Bores and keyways (i.e. metric, non-standard).

### Special Finishes

All clutches are supplied with a standard lacquer finish. Special coatings, finishes, or paints are also available upon request. Adding suffix - F2 to the model number will provide steel IT paint and food grade grease.

### Typical Limit Switch Layout

The layout in Figure 13 uses a single limit switch to detect an overload condition. The switch should be able to operate within the travel of the limit switch plate. Upon overload the limit switch plate will move to actuate the limit switch and shut down the drive.

The switch should be wired in parallel with a jog circuit so that the drive can be indexed for re-engagement. After the clutch has been re-engaged, the limit switch will be reset and the drive can be restarted.

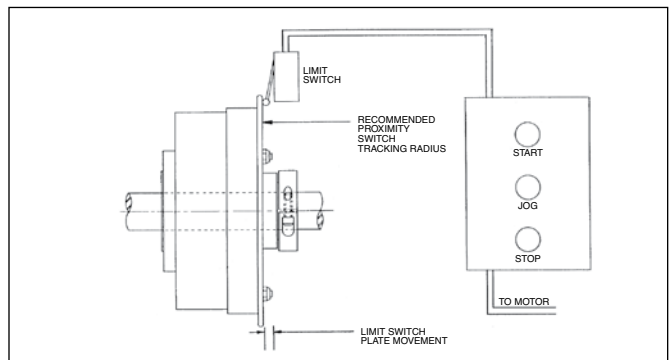

Figure 13

The limit switch actuating plate supplied with the Model F Trig-O-Matic Overload Clutch is furnished with a mild steel plate suitable for use with a proximity sensor.

### Limit Switch

Clutch Size	Movement (Inch)	Tracking Radius (Inch)
1	.18	2.38
2	.18	3.25
3	.18	4.18
4	.18	5.25
5	.18	6.25

# Trig-O-Matic Overload Clutches

## Torque Limiter Application Data

Fax To 800-816-5608

Please select your product intent below and provide as much application information as possible.

### 1. Application:

- New
- Existing
  - Replacement Model # \_\_\_\_\_

### 2. Power transmission requirements at clutch location:

- RPM \_\_\_\_\_
- Limiting Torque Level \_\_\_\_\_

### 3. Type:

- Mechanical (Spring Loaded)
- Pneumatic

### 4. Type:

- Fully Automatic Re-Engagement
- Manual (Free Wheeling)
- Semi Automatic (ORC model only)

### 5. Method of Torque Transmission:

- Flexible Coupling
  - Rigid Coupling
  - Sprocket Mount
- Sprocket Size and Tooth Count \_\_\_\_\_

### 6. Bore Size:

- Sprocket Mount (Clutch Bore) \_\_\_\_\_
- Coupling Mount (Clutch Bore) \_\_\_\_\_  
(Coupling Bore) \_\_\_\_\_

### 7. Shut Down Method:

- Prox Plate
- Pin Style (ORC only)
- None Required

Name: \_\_\_\_\_

Phone # \_\_\_\_\_

Fax # \_\_\_\_\_

Company \_\_\_\_\_

E-Mail \_\_\_\_\_

Use the space below to note any relevant application data or to detail your question.

---

---

---

---

---

---

---

---

---

---

---

---

---

---

---

---

---

---

# H1600 Mechanical Overload Clutches HOR Series

---



## Section Contents

FEATURES .....	36
OPERATING PRINCIPLES .....	36
SELECTION.....	37
HOW TO ORDER.....	37
RATINGS AND DIMENSIONS .....	38
MOUNTING HOLE PATTERNS .....	42
GENERAL INFORMATION .....	43

# H1600 Overload Clutches HOR Series

## Features

- Bi-directional operation
- Single position indexing
- Automatic reset
- Convenient torque adjustment
- Maximum torque limit stop
- Limit switch actuating mechanism
- Clamp collar for secure mounting
- Hardened components for long life
- Electroless nickel finish and stainless steel hardware for superior corrosion resistance
- Sealed from environmental contamination
- Interchanges POR Series
- Available in all Stainless upon request

## Operating Principles

The HOR Series H1600 is an automatic reset ball detent style overload release clutch. It has been designed to provide accurate and dependable torque disconnect protection for mechanical power transmission equipment. Torque is transmitted through the clutch in one of two paths. Refer to Figure 1.

Figure 1

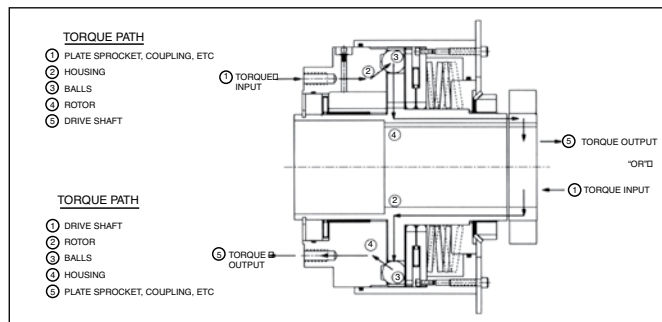

Torque transmission between the balls and housing is the key to the disengagement of the clutch. The balls are forced into the pockets of the housing by an axial load generated by compressing a spring pack. This axial load determines the torque capacity of the clutch. Increasing or decreasing the spring compression or changing spring packs provides a means for multiple torque adjustments. When a torque overload condition occurs, the balls roll out of the pockets and freewheel similar to a ball thrust bearing. This rolling action increases the efficiency in which the clutch operates and reduces any fluctuation of torque setting due to frictional changes. Refer to Figure 2.



The movement of the cover during disengagement can be used to trip a limit switch and signal a torque overload condition. The drive should be shut down immediately and the source of the overload determined and cleared. The drive can then be restarted. The automatic reset feature of the clutch will allow it to reengage without manual assistance and the clutch will once again be ready to provide accurate and dependable torque disconnect protection for your equipment.

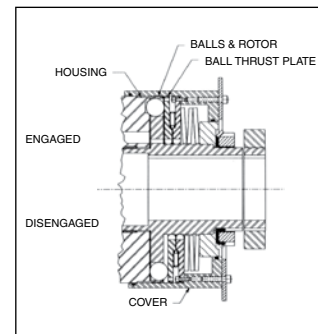

Figure 2

## Torque Adjustment

The HOR Series H1600 Series Clutch can be factory set to your requirements. The torque setting of the clutch can easily be adjusted in the field to suit your needs. Two degrees of adjustment are available and described below.

**Fine Adjustment:** Lift the bearing lock washer tabs which secure the nut in position. Use a spanner wrench to adjust the bearing nut to your desired torque setting. Clockwise rotation will increase the torque and conversely, counterclockwise rotation will decrease the torque. Once the desired torque setting is made, fold the tab of the washer over the slot on the bearing nut to secure it in position at the new torque release level.

**Coarse Adjustment:** Large variations in torque setting can be accomplished by replacing the disc spring pack with that of a higher or lower spring rate. This change will effectively alter the load which can be applied to the balls.

# H1600 Overload Clutches HOR Series

## Selection

- Determine the overload release torque by one of these methods:
  - Use the torque formula with horsepower and RPM specific to the selected clutch location. A service factor may be required for high inertia starts, reversing or peak load conditions, (refer to Page 98 for service factor information. For average applications, a service factor "SF" of 1.25 is recommended):
 
$$\text{Torque (Lb. In.)} = \frac{\text{HP} \times 63025}{\text{RPM}} \times \text{SF}$$
  - Determine the "weak link" in the drive train, (i.e., chain, reducer, belt or shaft). Select an overload release torque below the "weak link's" maximum torque rating.
  - Physically measure the drive torque with a torque wrench and size accordingly.
- Determine the bore size(s) and keyway(s):
  - Shaft size at the clutch location determines clutch bore.
  - Shaft size at the coupling location determines coupling bore (if applicable).
- Choose the appropriate Style based upon the drive layout and available space (See Figure 3).
- Refer to the Basic Selection Chart for the appropriate clutch size.
- Refer to Part Numbering System to complete selection.

Figure 3

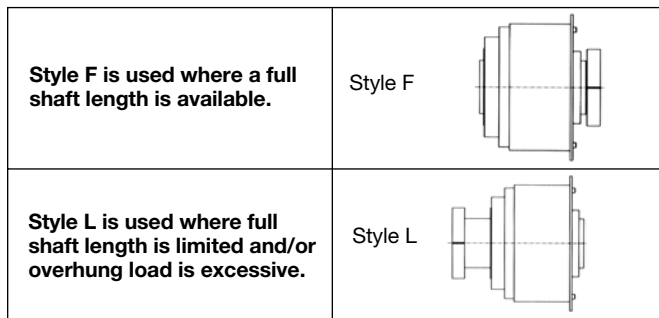

Basic Selection Chart

Clutch Size	Max. Bore* (In.)	Torque Code	Torque Range (Lb. In.)
02	F - 0.5625 L - 0.6875	L	25-60
		M	50-125
		H	75-175
		W	100-250
04	F - 1.1250 L - 1.2500	L	175-550
		M	250-850
		H	350-1,300
		W	600-2,000
05	F - 1.6250 L - 1.8125	L	350-1,200
		M	500-1,800
		H	750-2,600
		W	1,000-4,000
		Y	1,650-6,000
06	2.1250	L	600-1,900
		M	750-2,700
		H	1,000-3,800
		W	1,500-5,600
09	3.1250	L	2,250-7,500
		M	3,000-10,500
		H	4,250-15,000
		W	6,250-22,500
11	3.6250	L	6,000-22,000
		M	9,000-32,000
		H	12,000-50,000

\*Maximum bores may require flat keys (supplied with unit).

## How to Order

When ordering a HOR Series H1600 Overload Clutch, please include code letters/numbers for series, size, style, type, torque range, unit bore and coupling bore (if applicable).

### Example:

Required size, 05 HOR Series H1600 Overload Clutch, standard style, flexible coupling, medium torque range, and a one inch bore on both the unit and coupling:

**HOR** **05** **F** **C** - **M** **P16** - **P16**

## HOR Series Part Numbering System

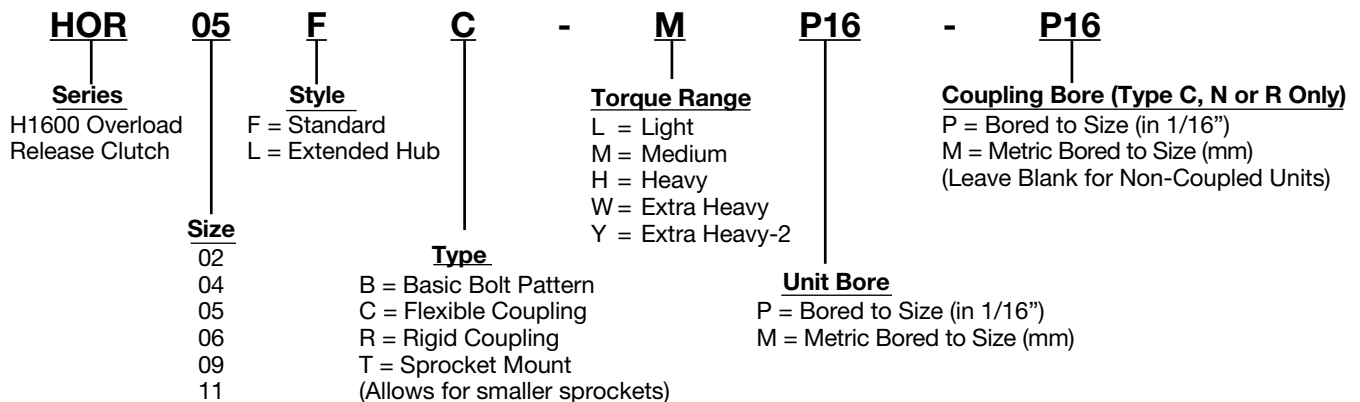

# H1600 Overload Clutches HOR Series

## Style F

### Type B Basic Sprocket Mounting

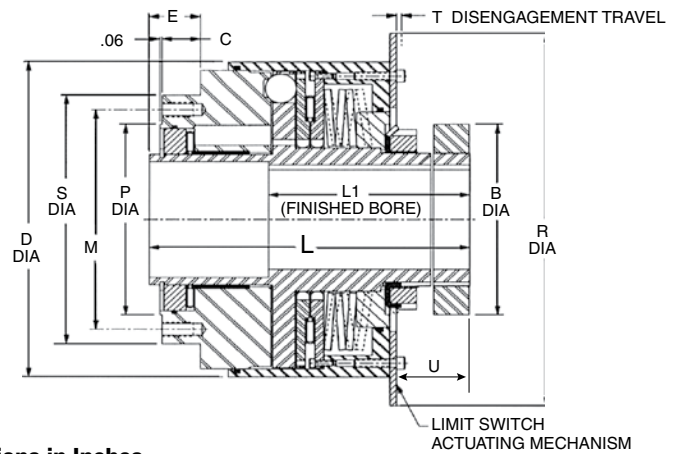
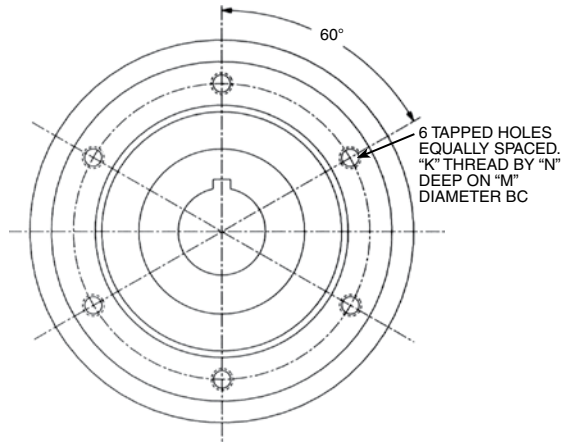

All Dimensions in Inches

Clutch Size	B	C	D	E	L	L1	P +.000/- .002	R	S	T	U	Mounting Holes		
												N	K	M
02	1.75	0.29	2.81	0.45	3.52	2.00	1.781	5.81	2.63	.060	.94	0.38	#8-32	2.125
04	2.38	0.35	4.25	0.56	4.79	3.00	2.688	7.25	3.63	.078	1.23	0.50	#10-24	3.062
05	3.50	0.43	5.88	0.70	6.20	3.88	3.625	8.88	5.00	.110	1.60	0.75	5/16-18	4.250
06	4.25	0.50	7.12	0.80	6.73	4.38	4.000	10.12	5.56	.128	1.71	0.81	3/8-16	4.750
09	5.75	1.03	9.50	1.40	9.00	5.50	5.750	12.50	7.56	.165	2.10	0.88	7/16-14	6.625
11	6.25	1.28	11.62	1.65	10.66	6.88	6.500	14.62	9.00	.183	2.69	1.00	5/8-11	7.750

### Ratings

Clutch Size	Torque Range (Lb. In.)				Max. RPM	WR <sup>2</sup> * (Lb.-In. <sup>2</sup> )	Weight* (Lbs.)
	Code	Min.	MRT	Max.			
02	L	25	45	60	500	3.4	3.9
	M	50	100	125			
	H	75	125	175			
	W	100	200	250			
04	L	175	400	550	500	22.3	11.0
	M	250	600	850			
	H	350	850	1,300			
	W	600	1,400	2,000			
05	L	350	900	1,200	500	129	30.2
	M	500	1,300	1,800			
	H	750	1,800	2,600			
	W	1,000	2,750	4,000			
	Y	1,650	4,000	6,000			
06	L	600	1,400	1,900	500	266	43.3
	M	750	1,900	2,700			
	H	1,000	2,600	3,800			
	W	1,500	3,900	5,600			
	Y	2,800	7,000	10,000			
09	L	2,250	5,500	7,500	500	1,155	104
	M	3,000	7,500	10,500			
	H	4,250	10,000	15,000			
	W	6,250	15,000	22,500			
11	L	6,000	15,000	22,000	500	2,995	171
	M	9,000	20,000	32,000			
	H	12,000	30,000	50,000			

### Clutch Bores

Clutch Size	Bores (inch)	
	Max. (1)	Max. (2)
02	0.5000	0.5625
04	1.0000	1.1250
05	1.5000	1.6250
06	1.9375	2.1250
09	2.8750	3.1250
11	3.1875	3.5000

Refer to Page 96 for a complete list of bore codes.

- (1) Square Key
- (2) Flat Key

### Minimum Number of Teeth Adaptable to Type B Clutches

Clutch Size	Type	Standard Chain Size and Pitch						
		#25 1/4 Pitch	#35 3/8 Pitch	#40 1/2 Pitch	#50 5/8 Pitch	#60 3/4 Pitch	#80 1 Pitch	#100 1-1/4 Pitch
02	B	39	27	22	—	—	—	—
04	B	51	35	28	23	—	—	—
05	B	69	47	36	30	26	—	—
06	B	76	52	40	33	28	—	—
09	B	101	68	52	43	36	28	24
11	B	119	80	61	50	43	33	27

\*Weight and WR<sup>2</sup> estimated with maximum bores.  
MRT is the Minimum Recommended Torque setting for those applications which require a minimal degree of backlash.  
Clutches are shipped set for the minimum torque value of the selected range.  
Refer to Page 37 for ordering information.



# H1600 Overload Clutches HOR Series

## Style L Extended Hub Type B Basic Sprocket Mounting

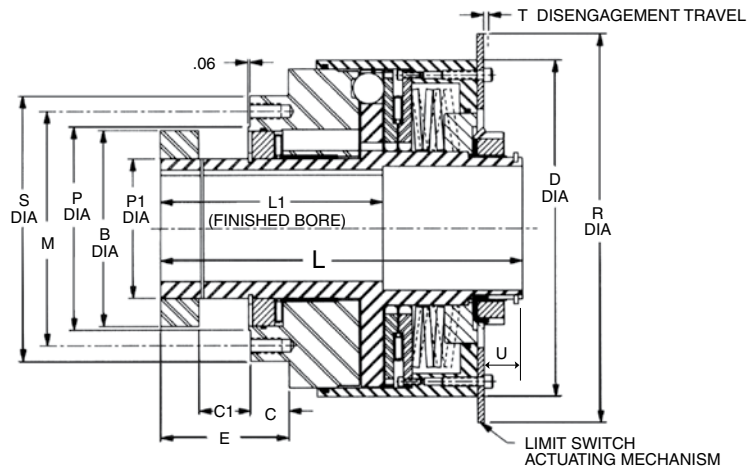
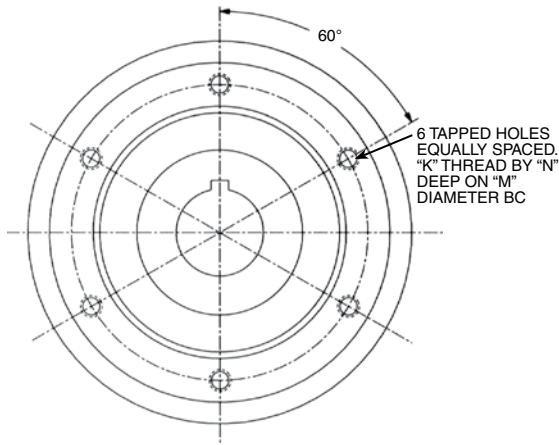

All Dimensions in Inches

Clutch Size	B	C	C1	D	E	L	L1	P +0.000/-0.002	P1		R	S	T	U	Mounting Holes		
									Min.	Max.					N	K	M
02	1.75	0.29	1.25	2.81	2.04	4.63	3.25	1.781	0.9843	0.9847	5.81	2.63	.060	.45	0.38	#8-32	2.125
04	2.38	0.35	1.44	4.25	2.35	6.06	3.88	2.688	1.5728	1.5738	7.25	3.63	.078	.74	0.50	#10-24	3.062
05	3.50	0.43	2.06	5.88	3.24	8.18	5.25	3.625	2.3623	2.3628	8.88	5.00	.110	1.06	0.75	5/16-18	4.250
06	4.25	0.50	3.62	7.12	4.87	10.25	6.88	4.000	2.7560	2.7566	10.12	5.56	.128	1.15	0.81	3/8-16	4.750
09	5.75	1.03	4.25	9.50	6.28	13.23	9.00	5.750	3.9350	3.9370	12.50	7.56	.165	1.50	0.88	7/16-14	6.625
11	6.50	1.28	4.50	11.62	7.16	15.01	10.00	6.500	4.7220	4.7240	14.62	9.00	.183	1.54	1.00	5/8-11	7.750

### Ratings

Clutch Size	Torque Range (Lb. In.)				Max. RPM	WR <sup>2*</sup> (Lb.-In. <sup>2</sup> )	Weight* (Lbs.)
	Code	Min.	MRT	Max.			
02	L	25	45	60	500	3.5	4.0
	M	50	100	125			
	H	75	125	175			
	W	100	200	250			
04	L	175	400	550	500	22.4	11.5
	M	250	600	850			
	H	350	850	1,300			
	W	600	1,400	2,000			
05	L	350	900	1,200	500	130	31.7
	M	500	1,300	1,800			
	H	750	1,800	2,600			
	W	1,000	2,750	4,000			
06	L	600	1,400	1,900	500	270	47.0
	M	750	1,900	2,700			
	H	1,000	2,600	3,800			
	W	1,500	3,900	5,600			
09	L	2,250	5,500	7,500	500	1,180	112
	M	3,000	7,500	10,500			
	H	4,250	10,000	15,000			
	W	6,250	15,000	22,500			
11	L	6,000	15,000	22,000	500	3,040	182
	M	9,000	20,000	32,000			
	H	12,000	30,000	50,000			

### Clutch Bores

Clutch Size	Bores (inch)	
	Max. (1)	Max. (2)
02	0.6250	0.6875
04	1.1250	1.2500
05	1.7500	1.8125
06	1.9375	2.1250
09	2.8750	3.1250
11	3.2500	3.6250

Refer to Page 96 for a complete list of bore codes.

- (1) Square Key
- (2) Flat Key

### Minimum Number of Teeth Adaptable to Type B Clutches

Clutch Size	Type	Standard Chain Size and Pitch						
		#25	#35	#40	#50	#60	#80	#100
		1/4 Pitch	3/8 Pitch	1/2 Pitch	5/8 Pitch	3/4 Pitch	1 Pitch	1-1/4 Pitch
02	B	39	27	22	—	—	—	—
04	B	51	35	28	23	—	—	—
05	B	69	47	36	30	26	—	—
06	B	76	52	40	33	28	—	—
09	B	101	68	52	43	36	28	24
11	B	119	80	61	50	43	33	27

\*Weight and WR<sup>2</sup> estimated with maximum bores.

MRT is the Minimum Recommended Torque setting for those applications which require a minimal degree of backlash.

Clutches are shipped set for the minimum torque value of the selected range.

Refer to Page 37 for ordering information.

# H1600 Overload Clutches HOR Series

## Style F

### Type C Flexible Coupling

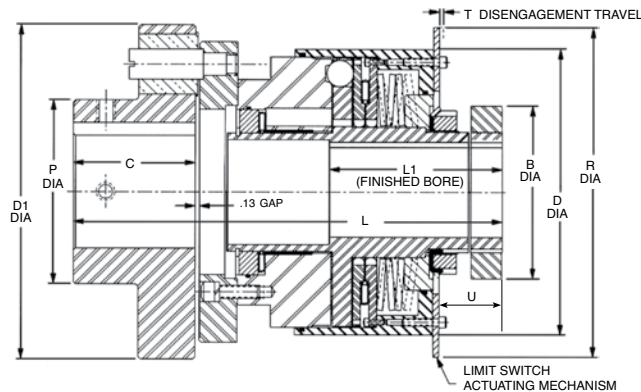

All Dimensions in Inches

Clutch Size	B	C	D	D1	L	L1	P	R	T	U	Max. Allowable Misalignment*	
											Parallel*	Angular*
02	1.75	1.25	2.81	3.94	5.50	2.00	2.50	5.81	.060	.94	.012	1°
04	2.38	1.25	4.25	5.13	6.64	3.00	3.25	7.25	.078	1.23	.016	1°
05	3.50	2.38	5.88	6.88	9.94	3.88	3.88	8.88	.110	1.60	.027	1°
06	4.25	2.88	7.12	8.13	11.25	4.38	4.25	10.12	.128	1.71	.045	1°
09	5.75	4.00	9.50	11.13	14.52	5.50	6.12	12.50	.165	2.10	.045	1°
11	6.25	4.50	11.62	14.00	16.67	6.88	7.50	14.62	.183	2.69	.045	1°

\*Parallel and Angular misalignment are proportionally reduced when both are present.

### Ratings

Clutch Size	Torque Range (Lb. In.)				Max. RPM	WR <sup>2</sup> * (Lb.-In. <sup>2</sup> )	Weight* (Lbs.)
	Code	Min.	MRT	Max.			
02	L	25	45	60	500	10.0	8.0
	M	50	100	125			
	H	75	125	175			
	W	100	200	250			
04	L	175	400	550	500	44.0	18.0
	M	250	600	850			
	H	350	850	1,300			
	W	600	1,400	2,000			
05	L	350	900	1,200	500	241	49.0
	M	500	1,300	1,800			
	H	750	1,800	2,600			
	W	1,000	2,750	4,000			
	Y	1,650	4,000	6,000			
06	L	600	1,400	1,900	500	550	82.0
	M	750	1,900	2,700			
	H	1,000	2,600	3,800			
	W	1,500	3,900	5,600			
	Y	2,800	7,000	10,000			
09	L	2,250	5,500	7,500	500	2,325	180
	M	3,000	7,500	10,500			
	H	4,250	10,000	15,000			
	W	6,250	15,000	22,500			
11	L	6,000	15,000	22,000	500	6,215	305
	M	9,000	20,000	32,000			
	H	12,000	30,000	50,000			

\*Weight and WR<sup>2</sup> estimated with maximum bores.  
MRT is the Minimum Recommended Torque setting for those applications which require a minimal degree of backlash.  
Clutches are shipped set for the minimum torque value of the selected range.  
Refer to Page 37 for ordering information.

### Clutch and Coupling Bores

Clutch Size	Type	Bores	
		Max. (1)	Max. (2)
02	Clutch	0.5000	0.5625
	Coupling	1.1875	-
04	Clutch	1.0000	1.1250
	Coupling	1.8750	-
05	Clutch	1.5000	1.6250
	Coupling	2.3125	2.3750
06	Clutch	1.9375	2.1250
	Coupling	2.6250	2.7500
09	Clutch	2.8750	3.1250
	Coupling	4.0000	4.1250
11	Clutch	3.1875	3.5000
	Coupling	4.6250	5.0000

Refer to Page 96 for a complete list of bore codes.  
(1) Square Key  
(2) Flat Key

# H1600 Overload Clutches HOR Series

## Style F

### Type R Rigid Coupling

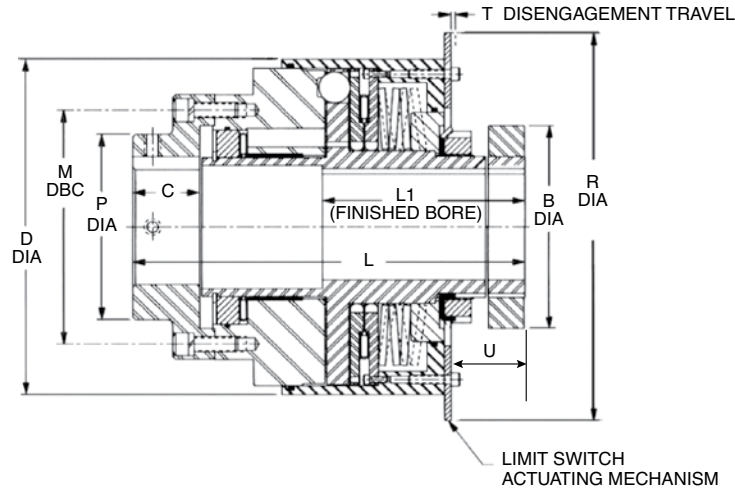

All Dimensions in Inches

Clutch Size	B	C	D	L	L1	M	P	R	T	U
02	1.75	0.75	2.81	4.36	2.00	2.125	1.38	5.81	.060	.94
04	2.38	1.62	4.25	6.51	3.00	3.062	2.50	7.25	.078	1.23
05	3.50	2.13	5.88	8.43	3.88	4.250	3.31	8.88	.110	1.60
06	4.25	2.20	7.12	9.02	4.38	4.750	3.50	10.12	.128	1.71
09	5.75	3.34	9.50	12.43	5.50	6.625	5.25	12.50	.165	2.10
11	6.25	3.96	11.62	14.77	6.88	7.750	6.00	14.62	.183	2.69

### Ratings

Clutch Size	Torque Range (Lb. In.)			Max. RPM	WR <sup>2*</sup> (Lb.-In. <sup>2</sup> )	Weight* (Lbs.)	
	Code	Min.	MRT				Max.
02	L	25	45	60	500	4.1	4.7
	M	50	100	125			
	H	75	125	175			
	W	100	200	250			
04	L	175	400	550	500	26.3	13.3
	M	250	600	850			
	H	350	850	1,300			
	W	600	1,400	2,000			
05	L	350	900	1,200	500	146	35.5
	M	500	1,300	1,800			
	H	750	1,800	2,600			
	W	1,000	2,750	4,000			
	Y	1,650	4,000	6,000			
06	L	600	1,400	1,900	500	296	50.9
	M	750	1,900	2,700			
	H	1,000	2,600	3,800			
	W	1,500	3,900	5,600			
	Y	2,800	7,000	10,000			
09	L	2,250	5,500	7,500	500	1,295	124
	M	3,000	7,500	10,500			
	H	4,250	10,000	15,000			
	W	6,250	15,000	22,500			
11	L	6,000	15,000	22,000	500	3,290	200
	M	9,000	20,000	32,000			
	H	12,000	30,000	50,000			

### Clutch and Coupling Bores

Clutch Size	Type	Bores	
		Max. (1)	Max. (2)
02	Clutch	0.5000	0.5625
	Coupling	0.7500	-
04	Clutch	1.0000	1.1250
	Coupling	1.6250	1.6875
05	Clutch	1.5000	1.6250
	Coupling	2.1250	2.2500
06	Clutch	1.9375	2.1250
	Coupling	2.2500	2.3125
09	Clutch	2.8750	3.1250
	Coupling	3.3750	3.5000
11	Clutch	3.1875	3.5000
	Coupling	4.0000	4.1250

Refer to Page 96 for a complete list of bore codes.

- (1) Square Key
- (2) Flat Key

\*Weight and WR<sup>2</sup> estimated with maximum bores.  
MRT is the Minimum Recommended Torque setting for those applications which require a minimal degree of backlash.  
Clutches are shipped set for the minimum torque value of the selected range.  
Refer to Page 37 for ordering information.

# H1600 Overload Clutches HOR Series

## Type T Adapter Mounts to Existing Housing Bolt Pattern

### Type T Sprocket, Pulley, Sheave or Gear Mount

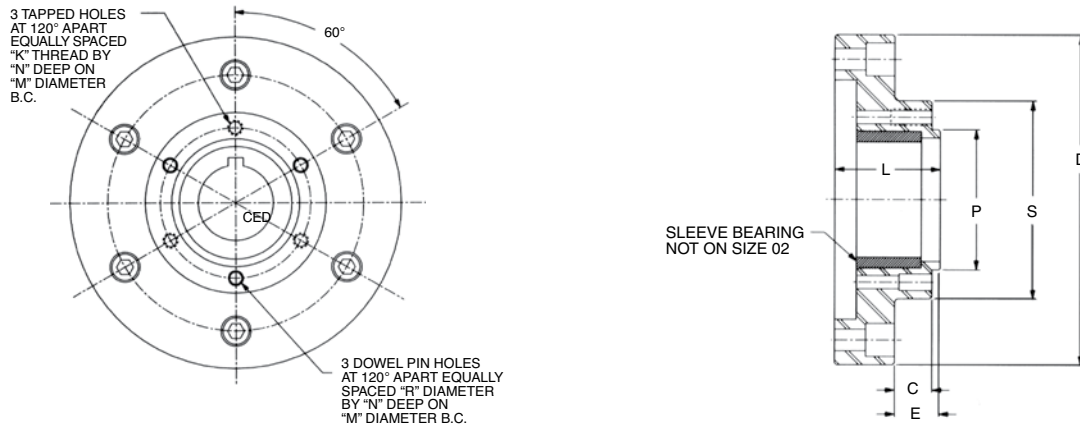

All Dimensions in Inches

Clutch Size	C	D	E	K	L	M	N	P +0.000/-0.002	R	S	WR <sup>2</sup> (Lb.-In. <sup>2</sup> )	Weight (Lbs.)
02	0.28	2.63	0.40	#8-32	0.71	1.422	.38	1.094	—	1.75	0.5	0.5
04	0.34	3.63	0.63	#8-32	1.02	2.250	.38	1.922	3/16	2.58	2.0	1.0
05	0.47	5.00	0.59	1/4-20	1.26	3.219	.50	2.750	1/4	3.66	12	3.0
06	0.69	5.56	0.81	1/4-20	1.55	3.406	.50	2.938	1/4	3.90	25	5.4
09	0.88	7.56	1.00	3/8-16	2.00	5.094	.75	4.344	3/8	5.84	93	11
11	1.02	9.00	1.14	3/8-16	2.32	5.938	.75	5.188	1/2	6.69	241	19

Mounting bolts must be minimum 160,000 PSI tensile, Rc 36-43

Dowel pins must be minimum 150,000 PSI shear, Rc 50-58 core hardness

### Minimum Number of Teeth Adaptable to Type T Clutches Type T Clutches Allow for the Use of Smaller Sprockets

Clutch Size	Type	Standard Chain Size and Pitch						
		#25 1/4 Pitch	#35 3/8 Pitch	#40 1/2 Pitch	#50 5/8 Pitch	#60 3/4 Pitch	#80 1 Pitch	#100 1-1/4 Pitch
02	T	27	19	15	—	—	—	—
04	T	37	26	20	17	—	—	—
05	T	50	35	27	23	19	—	—
06	T	54	37	29	24	20	16	14
09	T	79	54	41	34	29	23	19
11	T	90	61	47	38	32	25	21

The Type T adapter may be ordered separately or factory mounted to the HOR Series Clutches shown on Pages 38 and 39, by specifying Type T.

### Torque Adjustment Wrench

Standard bearing nuts are used to adjust the spring load which controls the release torque of the clutch. These nuts are slotted and can easily be turned using a common, commercially available hook style spanner wrench. Refer to the table below for wrenches which are compatible with Boston Gear's torque overload release clutches.

#### Torque Adjustment Wrench

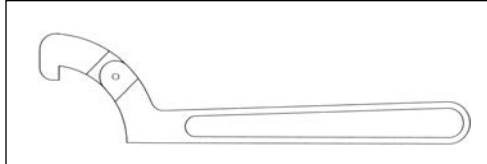

Clutch Size	Wrench Part Number				Specifications (Inches)			
	Armstrong Tool Co.	McMaster-Carr Supply Co.	Williams Tool Co.	Snap-On Tool Co.	Diameter Range	Hook Thick.	Hook Depth	Length
02	34-301	5471A11	471	AHS300	.75 to 2.00	.34	.13	6.38
02, 04	34-304	5471A12	472	AHS301	1.25 to 3.00	.41	.16	8.13
04, 05, 06	34-307	5471A13	474	AHS304	2.00 to 4.75	.47	.19	11.38
09, 11	34-310	5471A14	474A	AHS307	4.50 to 6.25	.47	.25	12.13
11	34-313	5471A23	474B	—	6.12 to 8.75	.47	.31	13.75

### Torque Overload Detection

The HOR Series H1600 Clutch is an automatic reset device designed for use when a fully disconnecting type is not desirable either because it is inaccessible and cannot be manually reset or because frequent resetting is not feasible. Because of this feature, it is important that the drive be shut down immediately upon a torque overload condition to prevent possible damage to the clutch caused by long-term reengaging and disengaging. Figure 4 utilizes a single limit switch to detect an overload condition. The switch should be able to operate within the disengagement travel of the clutch. Upon an overload, the cover of the clutch will move to actuate the limit switch and shut down the drive. The switch should be wired in parallel with a jog button so the drive can be indexed and permit the clutch to reengage at a safe speed. Once the clutch has been reengaged the limit switch will be reset and the drive can be restarted.

**Figure 4**  
Limit Switch Layout

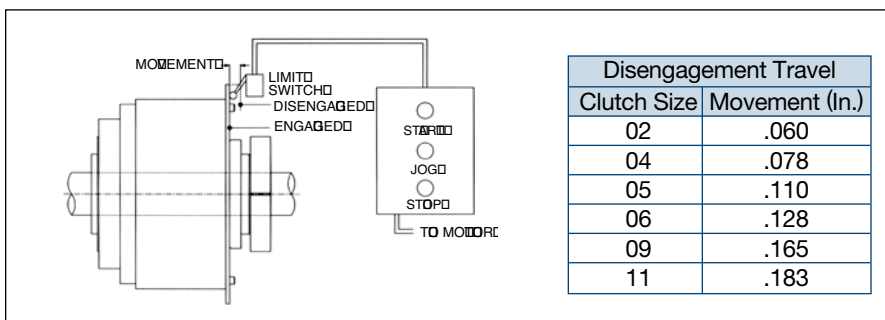

**Figure 5**  
Suggested Mounting Arrangements

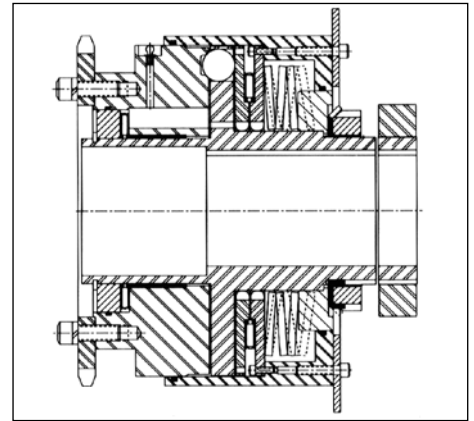

**Type B, Style F**  
with Sprocket Mounted

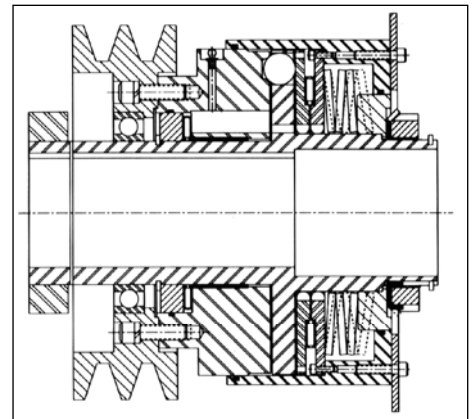

**Type B, Style L**  
with Sheave Mounted

# H1600 Overload Clutches

## Torque Limiter Application Data

Fax To 800-816-5608

Please select your product intent below and provide as much application information as possible.

### 1. Application:

- New
- Existing
  - Replacement Model # \_\_\_\_\_

### 2. Power transmission requirements at clutch location:

- RPM \_\_\_\_\_
- Limiting Torque Level \_\_\_\_\_

### 3. Type:

- Mechanical (Spring Loaded)
- Pneumatic

### 4. Type:

- Fully Automatic Re-Engagement
- Manual (Free Wheeling)
- Semi Automatic (ORC model only)

### 5. Method of Torque Transmission:

- Flexible Coupling
- Rigid Coupling
- Sprocket Mount

Sprocket Size and Tooth Count \_\_\_\_\_

### 6. Bore Size:

- Sprocket Mount (Clutch Bore) \_\_\_\_\_
- Coupling Mount (Clutch Bore) \_\_\_\_\_  
 (Coupling Bore) \_\_\_\_\_

### 7. Shut Down Method:

- Prox Plate
- Pin Style (ORC only)
- None Required

Name: \_\_\_\_\_

Phone # \_\_\_\_\_

Fax # \_\_\_\_\_

Company \_\_\_\_\_

E-Mail \_\_\_\_\_

Use the space below to note any relevant application data or to detail your question.

---

---

---

---

---

---

---

---

---

---

---

---

---

---

---

---

---

---

---

---

---

# H1900 Mechanical Overload Clutches WOR Series

---

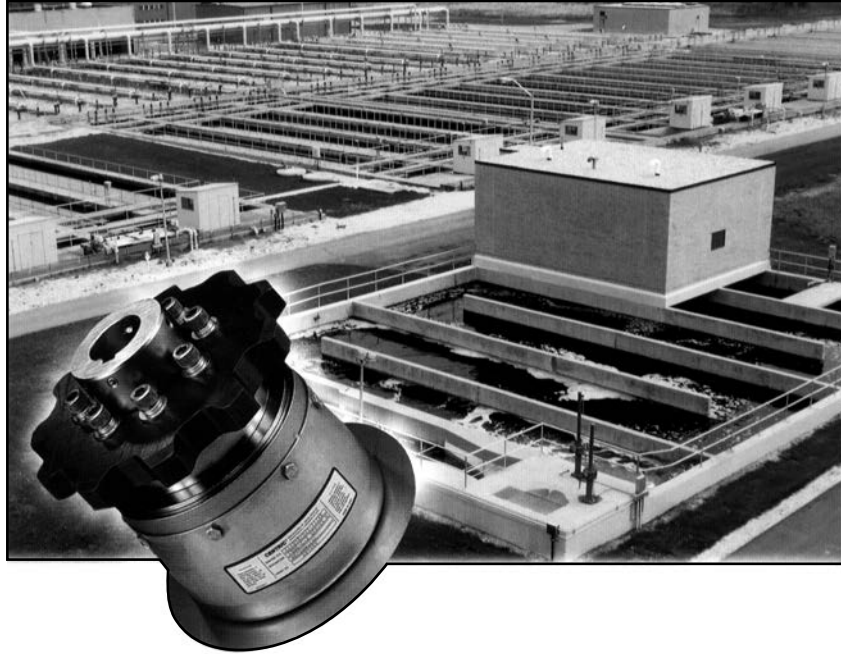

Designed for the water and wastewater industry

## Section Contents

FEATURES .....	46
OPERATING PRINCIPLES .....	46
SELECTION .....	47
HOW TO ORDER.....	47
RATINGS AND DIMENSIONS .....	48
GENERAL INFORMATION .....	51
SUGGESTED SPECIFICATIONS.....	51

# H1900 Overload Clutches Waste Water Industry WOR Series

## Features

- Automatic or manual reset
- Large bore capacity
- Through shaft or end shaft mounting
- Accurate torque release
- Stainless steel enclosure
- Electroless nickel plated
- Adaptable for all drives
- Operating parts are hardened for long life



## Operating Principles

The WOR Series H1900 is a mechanical ball detent overload release clutch. It has been designed to provide accurate and dependable torque overload protection for mechanical water and wastewater treatment equipment.

Torque is transmitted between the balls and the detents of the rotor in the following manner:

The chrome alloy balls are forced into the detents of the 50 Rc hardened rotor by an axial load generated by compressing a spring pack. This axial load is what determines the torque capacity of the clutch. Increasing or decreasing the spring compression or changing spring packs provides a means for multiple torque adjustments. When a torque overload condition occurs, the balls roll out of the rotor detents. This rolling action reduces any fluctuation in torque due to frictional changes (See Figure 1).

The movement of the cover during disengagement of the balls can be used to trip a limit switch and signal an overload condition. The drive should be shut down immediately and the source of the overload determined and cleared. After the clutch has been reset the drive can then be restarted.

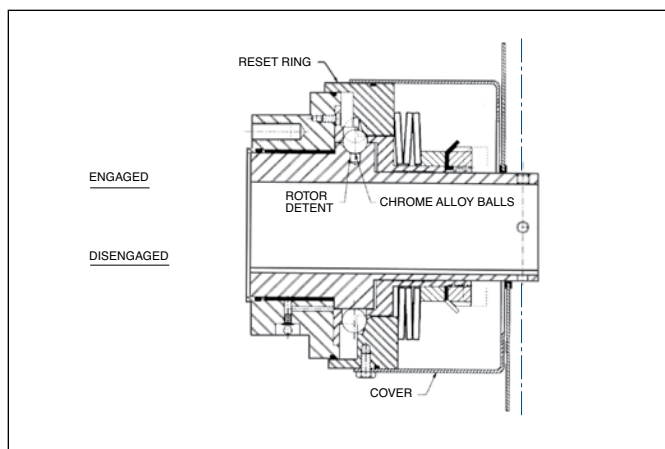

Figure 1

The **Manual Reset** (Style M or N) clutch can be reset in multiple positions. Rotate the drive until a lube fitting or a barring hole on the housing lines up with a tapped hole on the rotor. The rotor keyway should also be lined up with a lube fitting on the housing. After the proper position has been established, push evenly on both sides of the limit switch actuating plate. When the clutch is properly reset, the steel balls will move back into their detents and the actuating plate will return to its original position. An audible sound will be detected when the clutch re-engages, (See Figure 2).

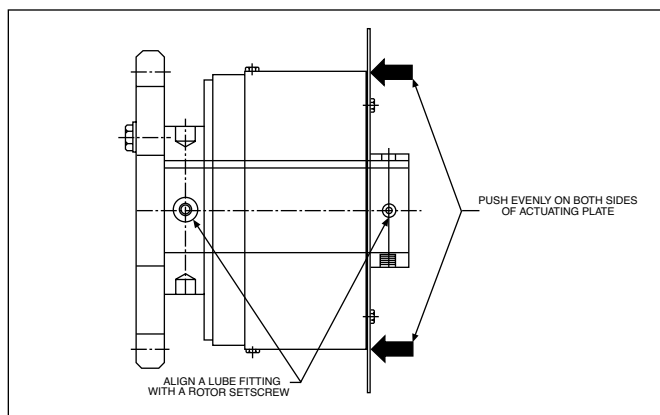

Figure 2

The **Automatic Reset** (Style A or B) version will re-engage without manual assistance. The steel balls will move back into their pockets every 1/4 of a revolution (1/8 of a revolution on the Size 11). After the overload condition has been cleared, jog the drive until the balls return to their detents and the actuating plate returns to its original position. An audible sound will be detected when the clutch re-engages.



# H1900 Overload Clutches

## Selection

1. Determine the overload release torque by one of these methods:

- Use the torque formula with horsepower and RPM specific to selected clutch location. A service factor may be required for high inertia starts, reversing or peak load conditions, (refer to Page 98 for service factor information. For average applications, a service factor "SF" of 1.25 is recommended):

$$\text{Torque (Lb. In.)} = \frac{\text{HP} \times 63025}{\text{RPM}} \times \text{SF}$$

- Maximum drive torque of chain: If using non-metallic chain, contact the manufacturer of the chain and ask for its maximum drive torque.
  - For shear pin replacement: Contact your local Boston Gear Area Sales Manager or the factory. They will gladly calculate the shear torque of your existing shear pins for you.
2. Determine the bore size and keyway.
3. Choose the proper style from Figures 3, 4, or 5 based upon the drive layout.
4. Refer to the Basic Selection Chart for the appropriate clutch size.

**Basic Selection Chart**

Size	Torque Code	Torque Range (Lb.-In.)		Maximum Bore (In.)*	
		Minimum	Maximum	Style A/M	Style B/N
05	L	850	1,700	1.7500	2.0000
	M	1,100	2,200		
	H	1,400	2,800		
	W	2,500	5,000		
06	L	1,250	2,500	2.2500	2.7500
	M	1,800	3,750		
	H	2,500	5,500		
	W	4,000	8,000		
09	L	2,250	5,750	3.0000	4.2500
	M	3,750	8,500		
	H	5,500	12,000		
	W	8,500	20,000		
11	L	5,000	12,000	4.0000	4.2500
	M	9,000	16,500		
	H	12,000	25,000		
	W	16,000	30,000		

\*Larger bores may require flat keys (supplied with unit).

**Figure 3**

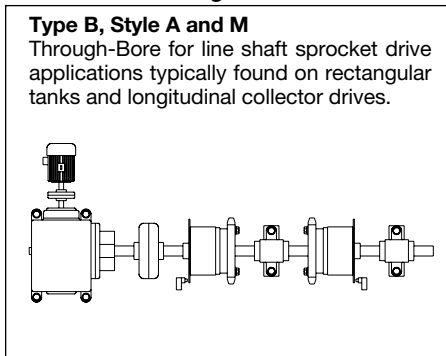

**Figure 4**

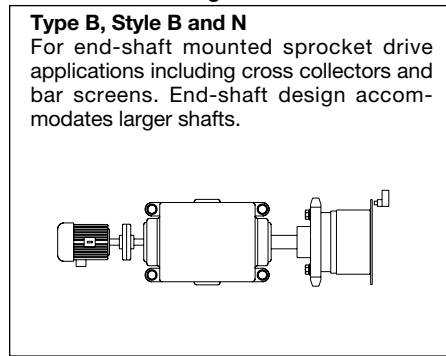

**Figure 5**

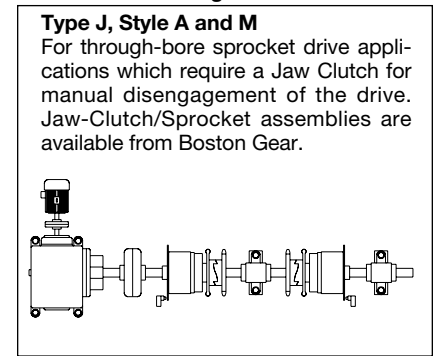

### WOR Series Part Numbering System

<p><b>WOR</b></p> <p>Series</p> <p>Wastewater Overload Release Clutch</p>	<p><b>05</b></p> <p>Size</p> <p>05 06 09 11</p>	<p><b>A</b></p> <p>Style</p> <p>A = Automatic Reset Through Bore B = Automatic Reset End Shaft M = Manual Reset Through Bore N = Manual Reset End Shaft</p>	<p><b>B</b></p> <p>Type</p> <p>B = Basic Bolt Pattern J = Jaw</p>	<p><b>-</b></p>	<p><b>L</b></p> <p>Torque Range</p> <p>L = Light M = Medium H = Heavy W = Extra Heavy</p>	<p><b>P16</b></p> <p>Unit Bore</p> <p>P = Bored to Size (in 1/16") M = Metric Bored to Size (mm)</p>
---	---	---	---	-----------------	---	--

## How to Order

When ordering a WOR Series H1900 Overload Clutch for Wastewater Treatment applications, please include code letters/numbers for series, size, style, type, torque range, and bore size.

### Example:

Required size, 05 WOR Series H1900 Overload Clutch, automatic reset, through-bore mounting, basic type, medium torque range, with a one inch bore:



# H1900 Overload Clutches WOR Series

## Style A and M Through-Bore

### Type B Basic Sprocket Mounting

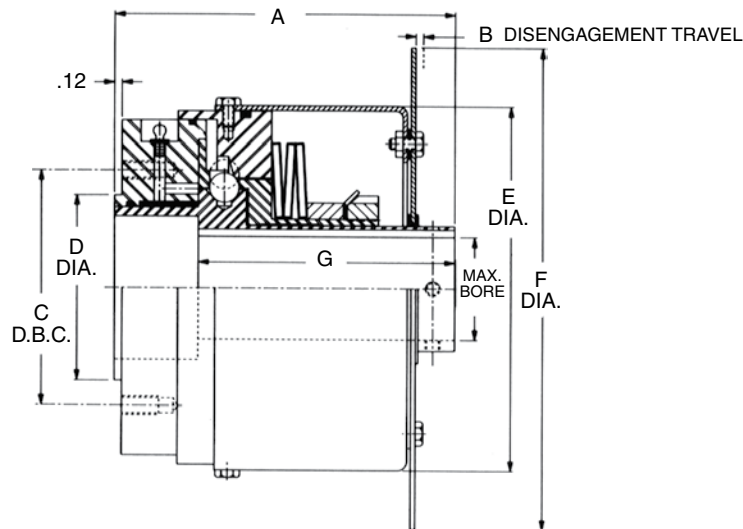

All Dimensions in Inches

Clutch Size	A	B	C	D +0.000/-0.002	E	F	G	Mounting Holes			Min. H78 Sprocket
								No.	Thread	Depth	
05	5.76	.13	4.000	3.123	6.19	8.19	4.50	6	5/16-18	0.75	9 Tooth
06	7.45	.17	4.875	4.000	7.62	9.62	5.25	8	1/2-13	1.12	9 Tooth
09	9.14	.19	4.875	4.000	9.65	11.62	6.12	8	1/2-13	1.25	9 Tooth
11	10.00	.19	6.500	5.500	9.65	11.62	7.00	8	1/2-13	1.25	11 Tooth

### Ratings

Clutch Size	Torque Code	Torque Range (Lb. In.)		Max. RPM	Weight (Lbs.)
		Min.	Max.		
05	L	850	1,700	50	24
	M	1,100	2,200		
	H	1,400	2,800		
	W	2,500	5,000		
06	L	1,250	2,500	50	40
	M	1,800	3,750		
	H	2,500	5,500		
	W	4,000	8,000		
09	L	2,250	5,750	50	80
	M	3,750	8,500		
	H	5,500	12,000		
	W	8,500	20,000		
11	L	5,000	12,000	50	87
	M	9,000	16,500		
	H	12,000	25,000		
	W	16,000	30,000		

### Clutch Bores

Clutch Size	Bores (inch)		
	Min.	Max. (1)	Max. (2)
05	0.6250	1.6250	1.7500
06	0.6250	2.1250	2.2500
09	1.0000	2.7500	3.0000
11	1.0000	3.7500	4.0000

Refer to Page 96 for a complete list of bore codes.

- (1) Square Key
- (2) Flat Key

Clutches are shipped set for the minimum torque value of the specified range.

Refer to Page 47 for ordering information.

# H1900 Overload Clutches WOR Series

## Style B and N End-Shaft Type B Basic Sprocket Mounting

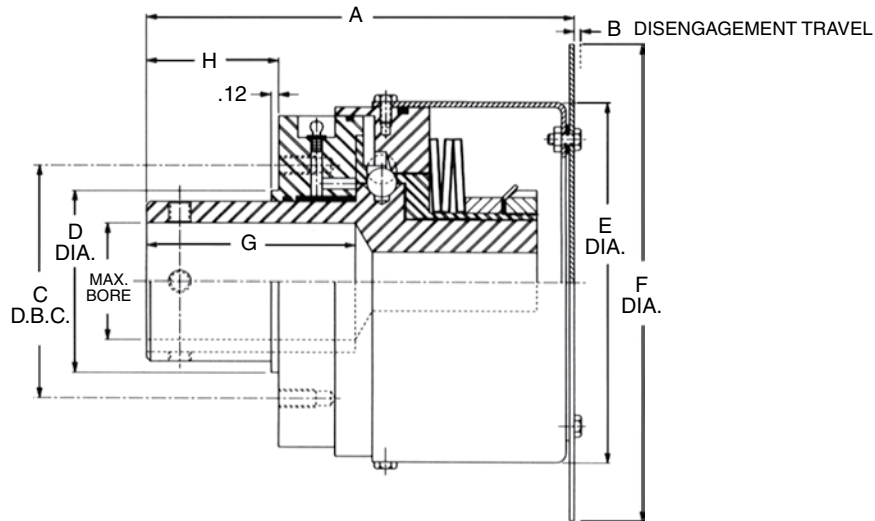

All Dimensions in Inches

Clutch Size	A	B	C	D +0.000/-0.002	E	F	G	H	Mounting Holes			Min. H78 Sprocket
									No.	Thread	Depth	
05	7.00	0.13	4.000	3.123	6.19	8.19	3.30	2.09	6	5/16-18	0.75	9 Tooth
06	9.04	0.17	4.875	4.000	7.62	9.62	4.69	2.56	8	1/2-13	1.12	9 Tooth
09	10.75	0.19	6.500	5.500	9.65	11.62	5.88	3.00	8	1/2-13	1.25	11 Tooth
11	11.44	0.19	6.500	5.500	9.65	11.62	5.88	3.00	8	1/2-13	1.25	11 Tooth

### Ratings

Clutch Size	Torque Code	Torque Range (Lb. In.)		Max. RPM	Weight (Lbs.)
		Min.	Max.		
05	L	850	1,700	50	25
	M	1,100	2,200		
	H	1,400	2,800		
	W	2,500	5,000		
06	L	1,250	2,500	50	42
	M	1,800	3,750		
	H	2,500	5,500		
	W	4,000	8,000		
09	L	2,250	5,750	50	83
	M	3,750	8,500		
	H	5,500	12,000		
	W	8,500	20,000		
11	L	5,000	12,000	50	87
	M	9,000	16,500		
	H	12,000	25,000		
	W	16,000	30,000		

### Clutch Bores

Clutch Size	Bores (inch)	
	Min.	Max. (1)
05	0.6250	2.0000
06	0.6250	2.7500
09	1.0000	4.2500
11	1.0000	4.2500

Refer to Page 96 for a complete list of bore codes.  
(1) Square Key

Clutches are shipped set for the minimum torque value of the specified range.

Refer to Page 47 for ordering information.

# H1900 Overload Clutches WOR Series

## Style A and M Through-Bore Type J Jaw Clutch Adapter

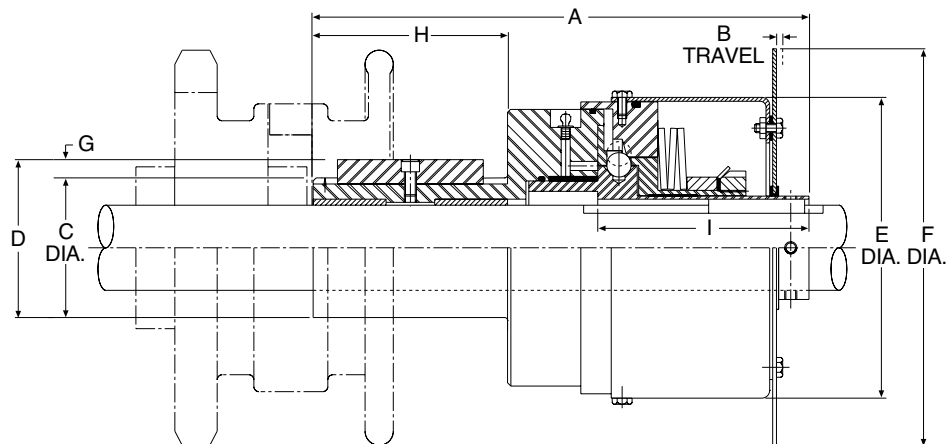

All Dimensions in Inches

Clutch Size	A	B	C	D +0.000/-0.002	E	F	G	H	I
05	10.20	.13	2.875	3.250	6.19	8.19	.38	4.00	4.50
06	12.25	.17	3.500	3.875	7.62	9.62	.38	4.50	5.25
09	14.62	.19	4.000	4.500	9.65	11.62	.50	5.00	6.12
11	15.87	.19	5.000	5.500	9.65	11.62	.50	5.50	7.00

### Ratings

Clutch Size	Torque Code	Torque Range (Lb. In.)		Max. RPM	Weight (Lbs.)
		Min.	Max.		
05	L	850	1,700	50	31
	M	1,100	2,200		
	H	1,400	2,800		
	W	2,500	5,000		
06	L	1,250	2,500	50	50
	M	1,800	3,750		
	H	2,500	5,500		
	W	4,000	8,000		
09	L	2,250	5,750	50	96
	M	3,750	8,500		
	H	5,500	12,000		
	W	8,500	20,000		
11	L	5,000	12,000	50	119
	M	9,000	16,500		
	H	12,000	25,000		
	W	16,000	30,000		

### Clutch Bores

Clutch Size	Bores (inch)		
	Min.	Max. (1)	Max. (2)
05	0.6250	1.6250	1.7500
06	0.6250	2.1250	2.2500
09	1.0000	2.7500	3.0000
11	1.0000	3.7500	4.0000

Refer to Page 96 for a complete list of bore codes.

- (1) Square Key
- (2) Flat Key

Clutches are shipped set for the minimum torque value of the specified range.

Refer to Page 47 for ordering information.

### Limit Switch Layout

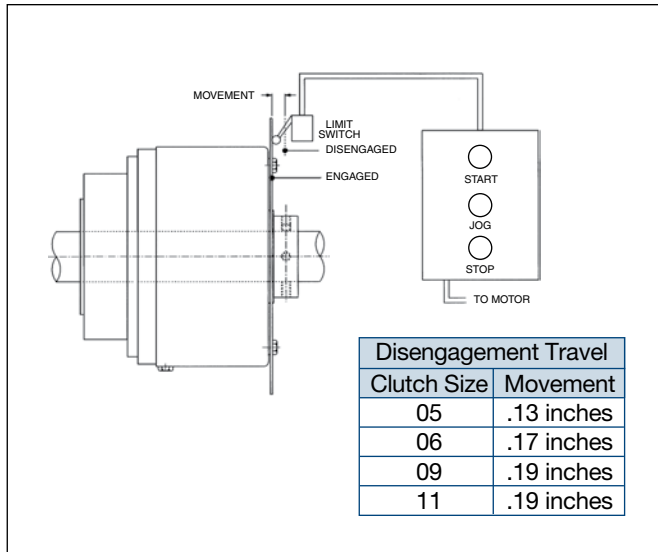

Figure 6

### Torque Overload Detection

The WOR Series H1900 is offered with an automatic reset (Style A/B). Because of this feature, it is important that the drive be shut down immediately upon a torque overload condition. Figure 6 utilizes a single limit switch to detect an overload. The switch should be able to operate within the disengagement travel of the clutch. Upon an overload, an oversized stainless steel plate attached to the cover will move to actuate the limit switch and shut down the drive.

### Torque Adjustment Wrench

Standard bearing nuts are used to adjust the spring load which controls the release torque of the clutch. These nuts are slotted and can easily be turned using a common, commercially available hook style spanner wrench. Refer to the table at bottom of this page for wrenches which are compatible with Boston Gear's torque overload release clutches.

### Suggested Specifications for Water and Wastewater Treatment Applications

Overload release clutches shall be installed to provide positive protection against damaging jams to the drives. They are to be located on the output sides of speed reducers, or as near as possible to the potential source of the overload so that the drive components are adequately protected.

The clutches shall be a ball detent type which when an overload occurs, the detent balls will roll free from their seat against pre-set spring pressure, completely disengaging the drive. Springs are to be a precision Belleville design conforming to spec. DIN-2092 and DIN-2093.

Resetting shall be a simple manual push back re-engagement (or automatic reset) and torque values will remain constant within plus or minus 10% after each disengagement or re-engagement.

All clutches shall be fully adjustable through a wide torque range to meet varying conditions and include a maximum torque limit stop to prevent adjustment beyond designed torque values. A circular plate is to be incorporated in the cover as a means to operate a limit switch to announce and/or stop the drive.

The clutches shall be completely sealed suitable for outdoor installations, including a stainless steel cover, electroless nickel plated external parts, and an external grease fitting for packing the units.

Chrome alloy steel detent balls shall be hardened to 60 Rc and all major internal components hardened to 50 Rc minimum for long life.

The WOR Series H1900 Overload Release Clutches shall be manufactured by Boston Gear, Charlotte, North Carolina 28216.

### Torque Adjustment Wrench

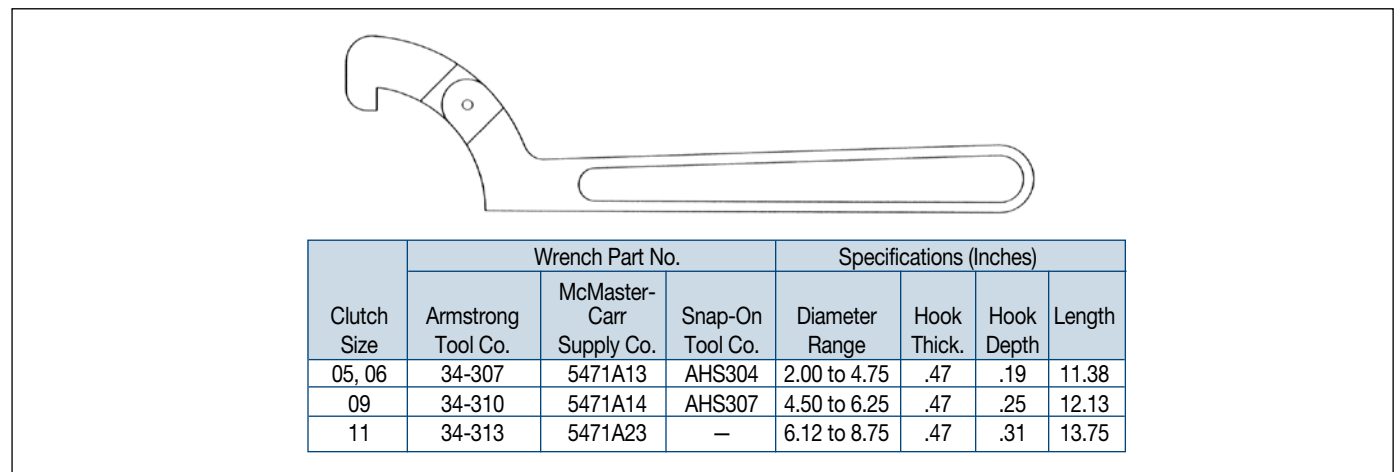

# H1900 Overload Clutches

## Torque Limiter Application Data

Fax To 800-816-5608

Please select your product intent below and provide as much application information as possible.

### 1. Application:

- New
- Existing  
- Replacement Model # \_\_\_\_\_

### 2. Power transmission requirements at clutch location:

- RPM \_\_\_\_\_
- Limiting Torque Level \_\_\_\_\_

### 3. Type:

- Mechanical (Spring Loaded)
- Pneumatic

### 4. Type:

- Fully Automatic Re-Engagement
- Manual (Free Wheeling)
- Semi Automatic (ORC model only)

### 5. Method of Torque Transmission:

- Flexible Coupling
  - Rigid Coupling
  - Sprocket Mount
- Sprocket Size and Tooth Count \_\_\_\_\_

### 6. Bore Size:

- Sprocket Mount (Clutch Bore) \_\_\_\_\_
- Coupling Mount (Clutch Bore) \_\_\_\_\_  
(Coupling Bore) \_\_\_\_\_

### 7. Shut Down Method:

- Prox Plate
- Pin Style (ORC only)
- None Required

Name: \_\_\_\_\_

Phone # \_\_\_\_\_

Fax # \_\_\_\_\_

Company \_\_\_\_\_

E-Mail \_\_\_\_\_

Use the space below to note any relevant application data or to detail your question.

---

---

---

---

---

---

---

---

---

---

---

---

# H2000 Pneumatic Overload Clutches

---



## Section Contents

FEATURES .....	54
OPERATING PRINCIPLES .....	54
SELECTION .....	55
HOW TO ORDER.....	55
RATINGS AND DIMENSIONS .....	56
GENERAL INFORMATION .....	61
TORQUE CURVES .....	62

# H2000 Pneumatic Overload Clutches    POR Series

## Features

- “In-Flight” torque control offers precise pneumatic torque control
- Remotely adjustable for starting and overrunning loads
- Bi-directional operation
- Single position indexing
- Automatic reset
- Through-shaft design
- Limit switch actuating mechanism
- Clamp collar for secure mounting
- Hardened parts for long clutch life
- Internal needle roller thrust bearings
- Lubrication fittings
- Sealed from environmental contamination
- Electroless nickel finish and stainless steel hardware for superior corrosion resistance
- Interchanges HOR Series

## Operating Principles

The POR Series H2000 is a pneumatic, ball detent style overload release clutch. It has been designed to provide accurate and dependable torque disconnect protection for mechanical power transmission equipment. Torque is transmitted through the clutch in one of two paths, (Refer to Figure 1).

Torque transmission between the balls and housing is the key to the disengagement of the clutch. The balls are forced into the pockets of the housing by an axial load generated by an

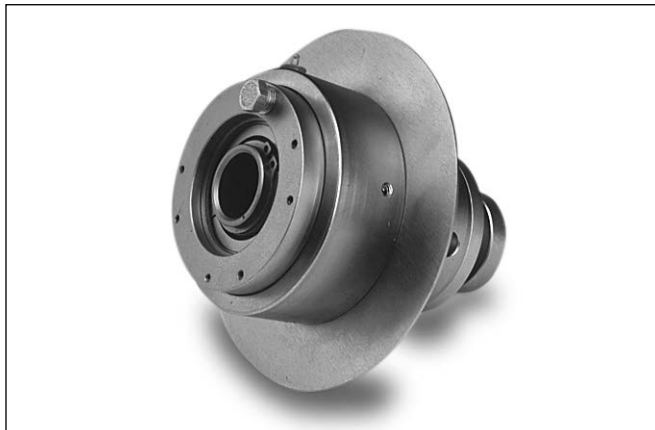

air cylinder. This axial load determines the torque capacity of the clutch. Increasing or decreasing the air pressure provides a means for remotely controlled precise “in-flight” torque adjustment. When a torque overload condition occurs, the balls roll out of the pockets and free wheel much as a ball thrust bearing. This rolling action increases the efficiency in which the clutch operates and reduces any fluctuation of torque setting due to frictional changes, (Refer to Figure 2).

The clutch has been designed with an internal valving mechanism. During an overload condition, the air is purged instantaneously from the cylinder.

The movement of the air cylinder during disengagement can be used to trip a limit switch and signal a torque overload condition. The drive should be shut down immediately and the source of the overload determined and cleared. The drive can then be restarted.

To engage the clutch, reapply air pressure and jog the drive until the clutch engages. Adjust the release torque by increasing the air pressure supplied to the clutch to reach the desired torque value. The clutch is now ready for normal operation.

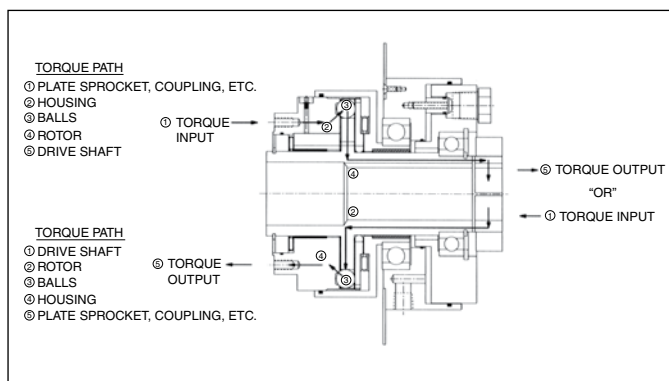

Figure 1

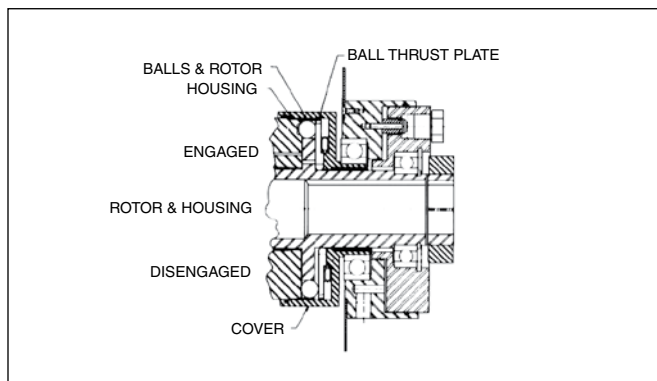

Figure 2



# H2000 Pneumatic Overload Clutches POR Series

## Selection

- Determine the overload release torque by one of these methods:
  - Use the torque formula with horsepower and RPM specific to the selected clutch location. A service factor may be required for high inertia starts, reversing or peak load conditions, (refer to Page 98 for service factor information. For average applications, a service factor "SF" of 1.25 is recommended):
 
$$\text{Torque (Lb. In.)} = \frac{\text{HP} \times 63025}{\text{RPM}} \times \text{SF}$$
  - Determine the "weak link" in the drive train, (i.e., chain, reducer, belt or shaft). Select an overload release torque below the "weak link's" maximum torque rating.
  - Physically measure the drive torque with a torque wrench and size accordingly.
- Determine the bore size(s) and keyway(s):
  - Shaft size at the clutch location determines the clutch bore.
  - Shaft size at the coupling location determines the coupling bore, (if applicable).
- Choose the appropriate Style (See Figure 3) based upon the drive layout and available space.
- Refer to the Basic Selection Chart for the appropriate clutch size. Determine the approximate start-up and running air pressures for the application.
- Refer to Part Numbering System to complete selection.

**Basic Selection Chart**

Clutch Size	Max.* Bore (In.)	Torque Code	Torque Range (Lb.-In.)	Max. RPM
02	0.750	H	120-470	3,600
04	1.187	H	400-1,400	1,800
05	1.750	L	850-2900	1,800
		H	1,350-4,700	
06	2.125	L	1,000-4,050	1,200
		H	2,800-7,800	
09	3.125	H	5,800-17,800	1,200
11	3.250	H	8,200-33,000	1,200

\*Larger bores may require flat keys (supplied with unit).

**Figure 3**

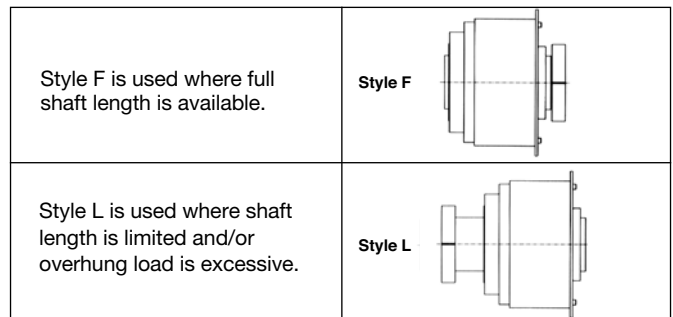

## POR Series Part Numbering System

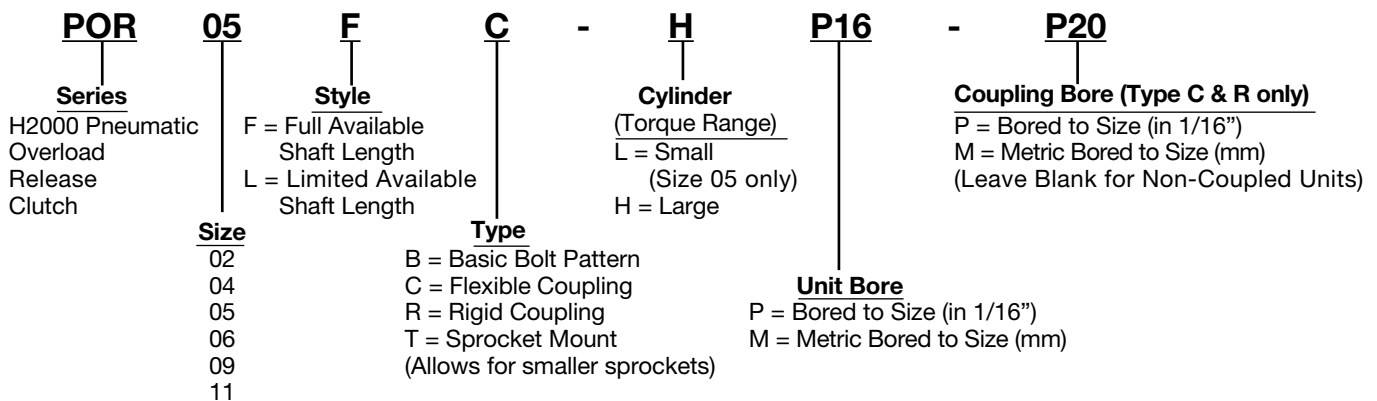

## How to Order

When ordering a POR Series H2000 Overload Clutch, please include code letters for series, size, style, type, torque range, unit bore and coupling bore (if applicable). Not all combinations are possible. Please refer to Pages 54-57 for details.

### Example:

Required size, 05 POR Series H2000 Overload Clutch, full available shaft length, flexible coupling, large torque range, with a one inch unit bore and a one inch coupling bore:

**POR** **05** **F** **C** - **H** **P16** - **P20** (Only include second bore "P20" if clutch is a coupling style)

# H2000 Pneumatic Overload Clutches POR Series

## Style F

### Type B Basic Sprocket Mounting

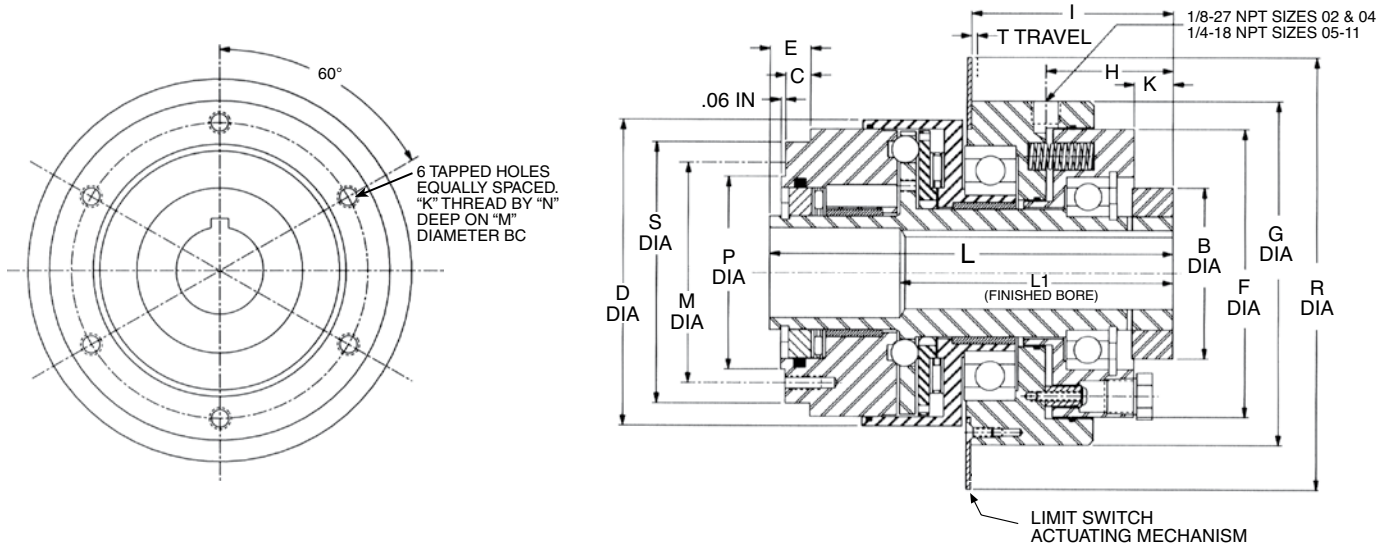

All Dimensions in Inches

Clutch Size	B	C	D	E	F	G	H	I	K	L	L1	P +.000/- .002	R	S	T	Weight (Lbs.)
02	1.75	0.29	2.81	0.45	3.50	3.88	1.84	2.19	0.56	4.47	2.95	1.781	5.81	2.63	.060	5.0
04	2.38	0.35	4.25	0.56	4.00	4.75	1.76	2.79	0.54	5.57	3.77	2.688	7.25	3.63	.078	11.6
05	3.50	0.43	5.87	0.70	6.25	6.63	2.87	3.33	0.77	6.88	4.57	3.625	8.88	5.00	.110	28.3
06	4.25	0.50	7.13	0.80	7.25	7.75	3.00	3.54	0.72	7.42	5.00	4.000	10.12	5.56	.128	41.0
09	5.75	1.03	9.50	1.40	9.25	10.00	3.87	4.63	1.03	9.75	6.30	5.750	12.50	7.56	.165	98.5
11	6.00	1.28	11.62	1.65	11.50	12.25	4.50	5.20	1.25	11.25	7.44	6.500	14.62	9.00	.183	155

### Mounting Detail

Clutch Size	Thread Depth N	Thread Size K	Bolt Centers M
02	0.38	8-32	2.125
04	0.50	10-24	3.062
05	0.75	5/16-18	4.250
06	0.81	3/8-16	4.750
09	0.88	7/16-14	6.625
11	1.00	5/8-11	7.750

### Clutch Bores

Clutch Size	Bores (inch)	
	Max. (1)	Max. (2)
02	0.6250	0.7500
04	1.1250	1.1875
05	1.5625	1.6250
06	2.0000	2.1250
09	2.8750	3.1250
11	3.1250	3.2500

Refer to Page 96 for a complete list of bore codes.

- (1) Square Key
- (2) Flat Key

### Ratings

Clutch Size	Torque Code	Torque Range (Lb. In.)	Max. RPM	WR2* (Lb-In <sup>2</sup> )
02	H	120 - 470	3,600	3.3
04	H	400-1,400	1,800	18.6
05	L	850-2,900	1,800	80.0
	H	1,350-4,700		
06	L	1,000-4,050	1,200	175
	H	2,800-7,800		
09	H	5,800-17,800	1,200	805
11	H	8,200-33,000	1,200	1,863

\*Estimated with maximum bores.

Clutches are shipped set for the minimum torque value for the selected range.

Refer to Page 55 for ordering information.

### Minimum Number of Teeth Adaptable to Type B Clutches

Clutch Size	Type	Standard Chain Size and Pitch						
		#25 1/4 Pitch	#35 3/8 Pitch	#40 1/2 Pitch	#50 5/8 Pitch	#60 3/4 Pitch	#80 1 Pitch	#100 1-1/4 Pitch
02	B	39	27	22	—	—	—	—
04	B	51	35	28	23	—	—	—
05	B	69	47	36	30	26	—	—
06	B	76	52	40	33	28	—	—
09	B	101	68	52	43	36	28	24
11	B	119	80	61	50	43	33	27

# H2000 Overload Clutches POR Series

## Style L

### Type B Basic Sprocket Mounting

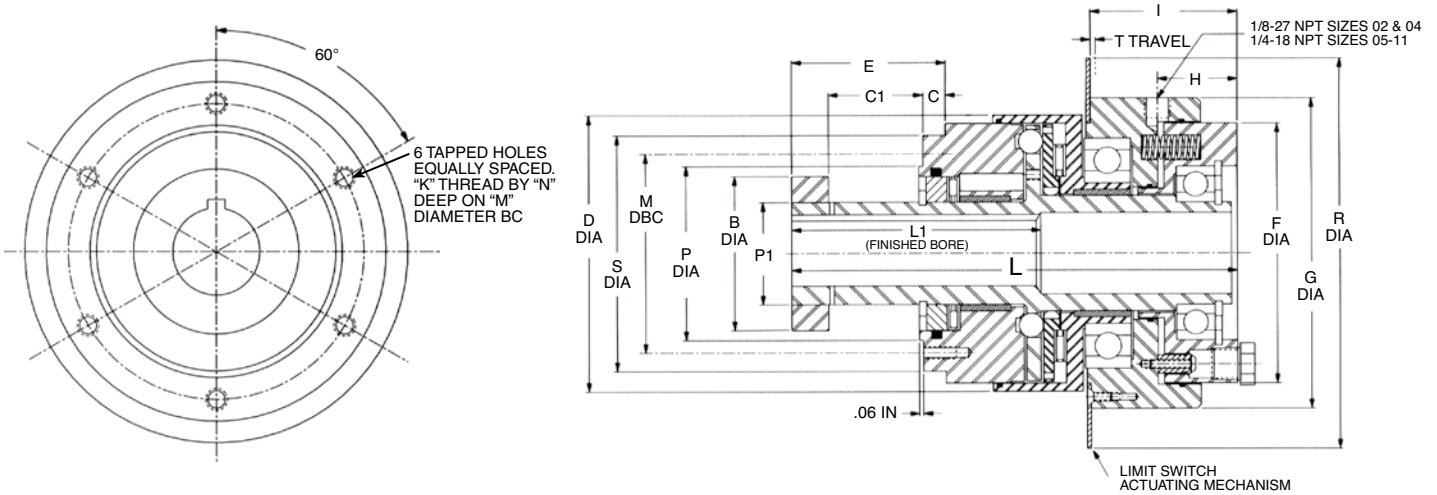

All Dimensions in Inches

Clutch Size	B	C	C1	D	E	F	G	H	I	L	L1	P +.000/-0.002	P1		R	S	T	Weight (Lbs.)
													Min.	Max.				
02	1.75	0.29	1.00	2.81	1.79	3.50	3.88	1.28	1.63	5.24	3.00	1.781	0.9843	0.9847	5.81	2.63	.060	5.2
04	2.38	0.35	1.44	4.25	2.35	4.00	4.75	1.22	2.25	6.83	3.81	2.688	1.5728	1.5738	7.25	3.63	.078	11.9
05	3.50	0.43	1.54	5.87	2.72	6.25	6.63	2.10	2.60	8.12	4.66	3.625	2.3623	2.3628	8.88	5.00	.110	28.9
06	4.25	0.50	2.25	7.13	3.50	7.25	7.75	2.28	2.82	9.40	5.46	4.000	2.7560	2.7566	10.12	5.56	.128	42.3
09	5.75	1.03	2.50	9.50	4.53	9.25	10.00	2.84	3.60	11.85	7.22	5.750	3.9350	3.9370	12.50	7.56	.165	103
11	6.50	1.28	2.63	11.62	5.28	11.50	12.25	3.25	3.95	13.63	8.16	6.500	4.7220	4.7240	14.62	9.00	.183	160

#### Mounting Detail

Clutch Size	Thread Depth N	Thread Size K	Bolt Centers M
02	0.38	8-32	2.125
04	0.50	10-24	3.062
05	0.75	5/16-18	4.250
06	0.81	3/8-16	4.750
09	0.88	7/16-14	6.625
11	1.00	5/8-11	7.750

#### Clutch Bores

Clutch Size	Bores (inch)	
	Max. (1)	Max. (2)
02	0.6250	0.7500
04	1.1250	1.1875
05	1.7500	—
06	2.0000	2.1250
09	2.8750	3.1250
11	3.1250	3.2500

Refer to Page 96 for a complete list of bore codes.

- (1) Square Key
- (2) Flat Key

#### Ratings

Clutch Size	Torque Code	Torque Range (Lb. In.)	Max. RPM	WR <sup>2*</sup> (Lb-In <sup>2</sup> )
02	H	120 - 470	3,600	3.4
04	H	400-1,400	1,800	18.9
05	L	850-2,900	1,800	81.7
	H	1,350-4,700		
06	L	1,000-4,050	1,200	178
	H	2,800-7,800		
09	H	5,800-17,800	1,200	820
11	H	8,200-33,000	1,200	1,889

\*Estimated with maximum bores.

Clutches are shipped set for the minimum torque value for the selected range.

Refer to Page 55 for ordering information.

#### Minimum Number of Teeth Adaptable to Type B Clutches

Clutch Size	Type	Standard Chain Size and Pitch						
		#25 1/4 Pitch	#35 3/8 Pitch	#40 1/2 Pitch	#50 5/8 Pitch	#60 3/4 Pitch	#80 1 Pitch	#100 1-1/4 Pitch
02	B	39	27	22	—	—	—	—
04	B	51	35	28	23	—	—	—
05	B	69	47	36	30	26	—	—
06	B	76	52	40	33	28	—	—
09	B	101	68	52	43	36	28	24
11	B	119	80	61	50	43	33	27

# H2000 Pneumatic Overload Clutches    POR Series

## Style F

### Type C Flexible Coupling

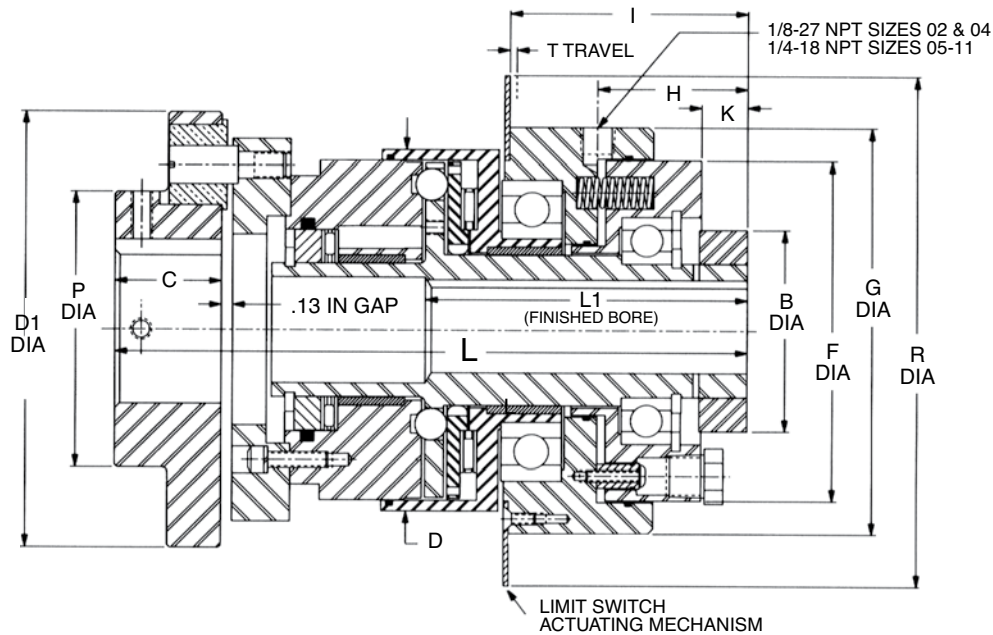

All Dimensions in Inches

Clutch Size	B	C	D	D1	F	G	H	I	K	L	L1	P	R	T	Parallel Offset	Angular Misalignment	Weight (Lbs.)
02	1.75	1.25	2.81	3.94	3.50	3.88	1.84	2.19	0.56	6.44	2.95	2.50	5.81	.060	.012	1°	8.6
04	2.38	1.25	4.25	5.13	4.00	4.75	1.76	2.79	0.54	7.42	3.77	3.25	7.25	.078	.016	1°	18.5
05	3.50	2.38	5.87	6.88	6.25	6.63	2.87	3.33	0.77	10.62	4.57	3.88	8.88	.110	.027	1°	47.2
06	4.25	2.88	7.13	8.13	7.25	7.75	3.00	3.54	0.72	11.94	5.00	4.25	10.12	.128	.045	1°	79.7
09	5.75	4.00	9.50	11.13	9.25	10.00	3.87	4.63	1.03	15.25	6.30	6.13	12.50	.165	.045	1°	174
11	6.00	4.50	11.62	14.00	11.50	12.25	4.50	5.20	1.25	17.26	7.44	7.50	14.62	.183	.045	1°	289

Parallel and angular misalignment are proportionally reduced when both are present.

### Torque Range Ratings

Clutch Size	Torque Code	Torque Range (Lb. In.)	Max. RPM	WR <sup>2*</sup> (Lb-In <sup>2</sup> )
02	H	120 - 470	3,600	9.6
04	H	400-1,400	1,800	39.5
05	L	850-2,900	1,800	192
	H	1,350-4,700		
06	L	1,000-4,050	1,200	458
	H	2,800-7,800		
09	H	5,800-17,800	1,200	1,975
11	H	8,200-33,000	1,200	5,083

\*Estimated with maximum bores.

Clutches are shipped set for the minimum torque value for the selected range.

### Clutch and Coupling Bores

Clutch Size	Type	Bores (inch)	
		Max. (1)	Max. (2)
02	Clutch	0.6250	0.7500
	Coupling	1.1875	-
04	Clutch	1.1250	1.1875
	Coupling	1.8750	-
05	Clutch	1.5625	1.6250
	Coupling	2.3125	2.3750
06	Clutch	2.0000	2.1250
	Coupling	2.6250	2.7500
09	Clutch	2.8750	3.1250
	Coupling	4.0000	4.1250
11	Clutch	3.1250	3.2500
	Coupling	4.6250	5.0000

Refer to Page 96 for a complete list of bore codes.

- (1) Square Key
- (2) Flat Key

Refer to Page 55 for ordering information.

# H2000 Overload Clutches POR Series

## Style F

### Type R Rigid Coupling

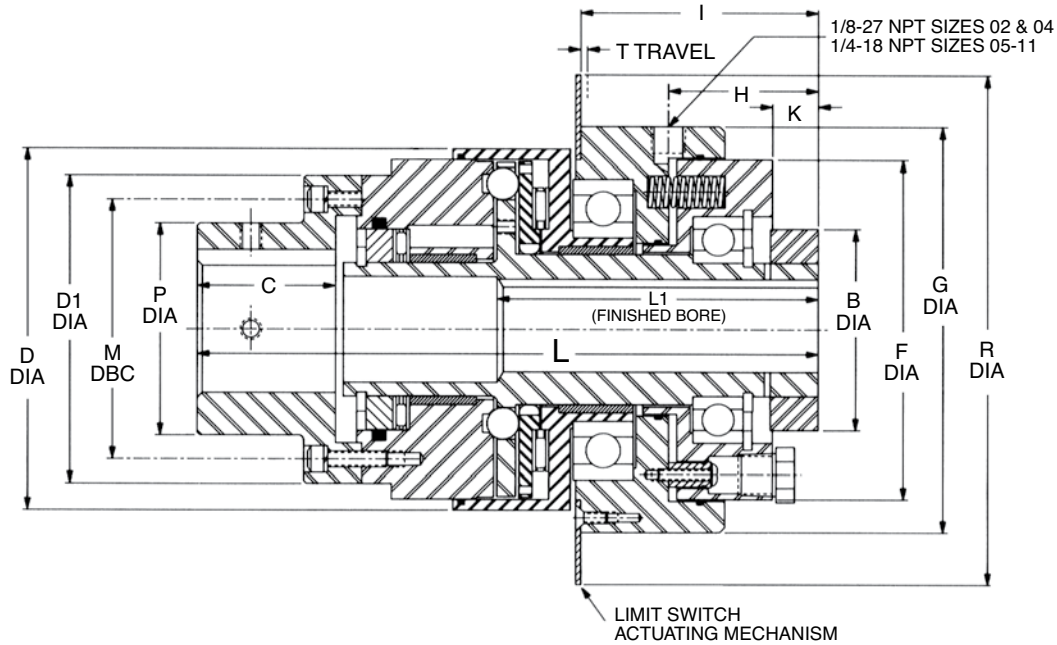

All Dimensions in Inches

Clutch Size	B	C	D	D1	F	G	H	I	K	L	L1	M	P	R	T	Weight (Lbs.)
02	1.75	0.75	2.81	2.63	3.50	3.88	1.84	2.19	0.56	5.31	2.95	2.125	1.38	5.81	.060	5.8
04	2.38	1.62	4.25	3.63	4.00	4.75	1.76	2.79	0.54	7.29	3.77	3.062	2.50	7.25	.078	13.9
05	3.50	2.13	5.87	5.00	6.25	6.63	2.87	3.33	0.77	9.11	4.57	4.250	3.31	8.88	.110	33.6
06	4.25	2.20	7.13	5.56	7.25	7.75	3.00	3.54	0.72	9.71	5.00	4.750	3.50	10.12	.128	48.6
09	5.75	3.34	9.50	7.56	9.25	10.00	3.87	4.63	1.03	13.18	6.30	6.625	5.25	12.50	.165	118
11	6.00	3.96	11.62	9.00	11.50	12.25	4.50	5.20	1.25	15.30	7.44	7.750	7.50	14.62	.183	184

### Ratings

Clutch Size	Torque Code	Torque Range (Lb. In.)	Max. RPM	WR <sup>2*</sup> (Lb-In <sup>2</sup> )
02	H	120 - 470	3,600	4.0
04	H	400-1,400	1,800	22.6
05	L	850-2,900	1,800	97.0
	H	1,350-4,700		
06	L	1,000-4,050	1,200	205
	H	2,800-7,800		
09	H	5,800-17,800	1,200	945
11	H	8,200-33,000	1,200	2,158

\*Estimated with maximum bores.  
Clutches are shipped set for the minimum torque value for the selected range.

### Clutch and Coupling Bores

Clutch Size	Type	Bores	
		Max. (1)	Max. (2)
02	Clutch	0.6250	0.7500
	Coupling	0.7500	-
04	Clutch	1.1250	1.1875
	Coupling	1.6250	1.6875
05	Clutch	1.5625	1.6250
	Coupling	2.1250	2.2500
06	Clutch	2.0000	2.1250
	Coupling	2.2500	2.3125
09	Clutch	2.8750	3.1250
	Coupling	3.3750	3.5000
11	Clutch	3.1250	3.2500
	Coupling	4.0000	4.1250

Refer to Page 96 for a complete list of bore codes.

- (1) Square Key
- (2) Flat Key

Refer to Page 55 for ordering information.

# H2000 Pneumatic Overload Clutches POR Series

## Style T Adapter Mounts to Existing Housing Bolt Pattern

### Type T Sprocket, Pulley, Sheave, or Gear Mount

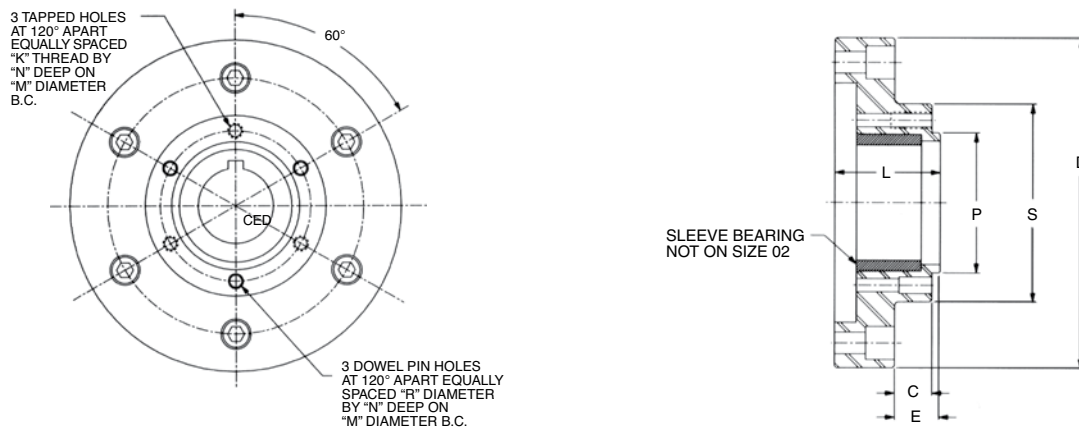

All Dimensions in Inches

Clutch Size	C	D	E	K	L	M	N	P +.000/-0.002	R	S	WR <sup>2</sup> (Lb.-In. <sup>2</sup> )	Weight (Lbs.)
02	0.28	2.63	0.40	#8-32	0.71	1.422	.38	1.094	—	1.75	0.5	0.5
04	0.34	3.63	0.63	#8-32	1.02	2.250	.38	1.922	3/16	2.58	2.0	1.0
05	0.47	5.00	0.59	1/4-20	1.26	3.219	.50	2.750	1/4	3.66	12	3.0
06	0.69	5.56	0.81	1/4-20	1.55	3.406	.50	2.938	1/4	3.90	25	5.4
09	0.88	7.56	1.00	3/8-16	2.00	5.094	.75	4.344	3/8	5.84	93	11
11	1.02	9.00	1.14	3/8-16	2.32	5.938	.75	5.188	1/2	6.69	241	19

Mounting bolts must be minimum 160,000 PSI tensile, Rc 36-43.

Dowel pins must be minimum 150,000 PSI shear, Rc 50-58 core hardness.

### Minimum Number of Teeth Adaptable to Type T Clutches Type T Clutches Allow for the Use of Smaller Sprockets

Clutch Size	Type	Standard Chain Size and Pitch						
		#25 1/4 Pitch	#35 3/8 Pitch	#40 1/2 Pitch	#50 5/8 Pitch	#60 3/4 Pitch	#80 1 Pitch	#100 1-1/4 Pitch
02	T	27	19	15	—	—	—	—
04	T	37	26	20	17	—	—	—
05	T	50	35	27	23	19	—	—
06	T	54	37	29	24	20	16	14
09	T	79	54	41	34	29	23	19
11	T	90	61	47	38	32	25	21

The Type T adapter may be ordered separately or factory mounted to the POR Series Clutches shown on Pages 56 and 57, by specifying Type T.

# H2000 Overload Clutches

## General Information

### Limit Switches

The POR Series H2000 clutch is an automatic reset device. It is important that the drive be shut down immediately upon a torque overload condition. The switch should be able to operate within the disengagement travel of the clutch. Upon an overload, the cylinder of the clutch will move to actuate the limit switch and shut down the drive. An oversized metallic plate provides a means for sensing movement from both ends and for utilizing a precision proximity switch.

As an option, Boston Gear offers a limit switch kit which mounts directly to the clutch. There are two sets of tapped holes on the face of the piston for mounting two limit switches. One switch may be used for your pneumatic control unit and the other switch may be used for the motor control. The motor control switch is used to open the circuit to the motor during a torque overload condition. The switch should be wired in its normally closed condition and in parallel with the JOG button of the motor control. This will permit the drive to be started in the event the clutch has stopped with the limit switch circuit in an open state.

The kit comes complete with a mechanical limit switch, mounting bracket and mounting hardware. Figure 4 shows the limit switch kits available for the POR Series H2000. Before using this switch in your circuit, verify that the electrical ratings meet your requirements.

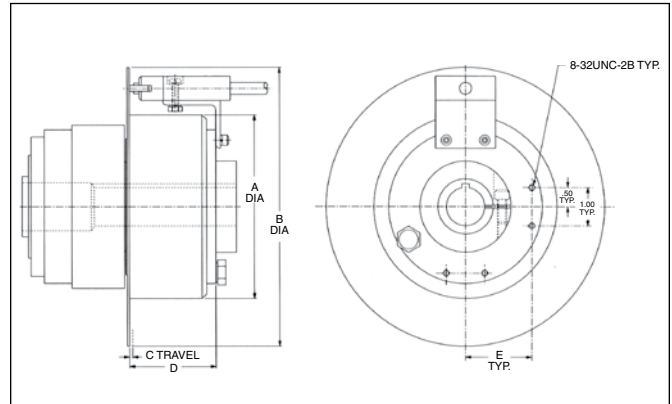

Clutch Size	A	B	C	D	E
02	3.88	5.81	.060	1.63	1.50
04	4.75	7.25	.078	2.25	1.73
05	6.63	8.88	.110	2.60	2.63
06	7.75	10.12	.128	2.82	3.06
09	10.00	12.50	.165	3.60	4.00
11	12.25	14.62	.183	3.95	5.00

Consult factory for ordering information.

**Figure 4**  
**Limit Switch Kit**

Clutch Size	Item Code
02 & 04	76493
05 & 06	76494
09 & 11	17571

**Figure 5**  
**Suggested Mounting Arrangements**

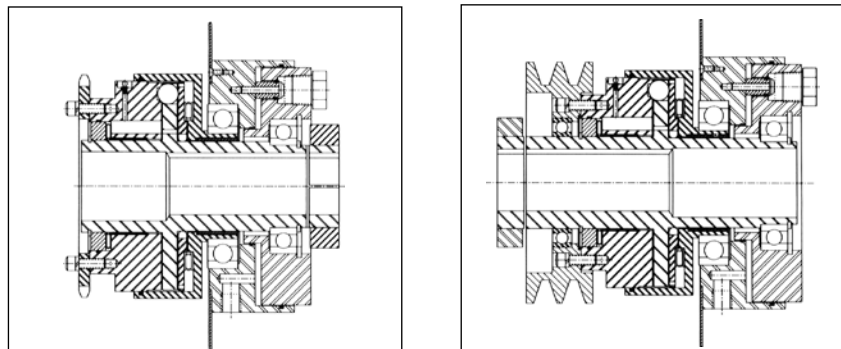

**Type B, Style F**  
**with Sprocket Mounted**

**Type B, Style L**  
**with Sheave Mounted**

# H2000 Pneumatic Overload Clutches

## Torque Curves

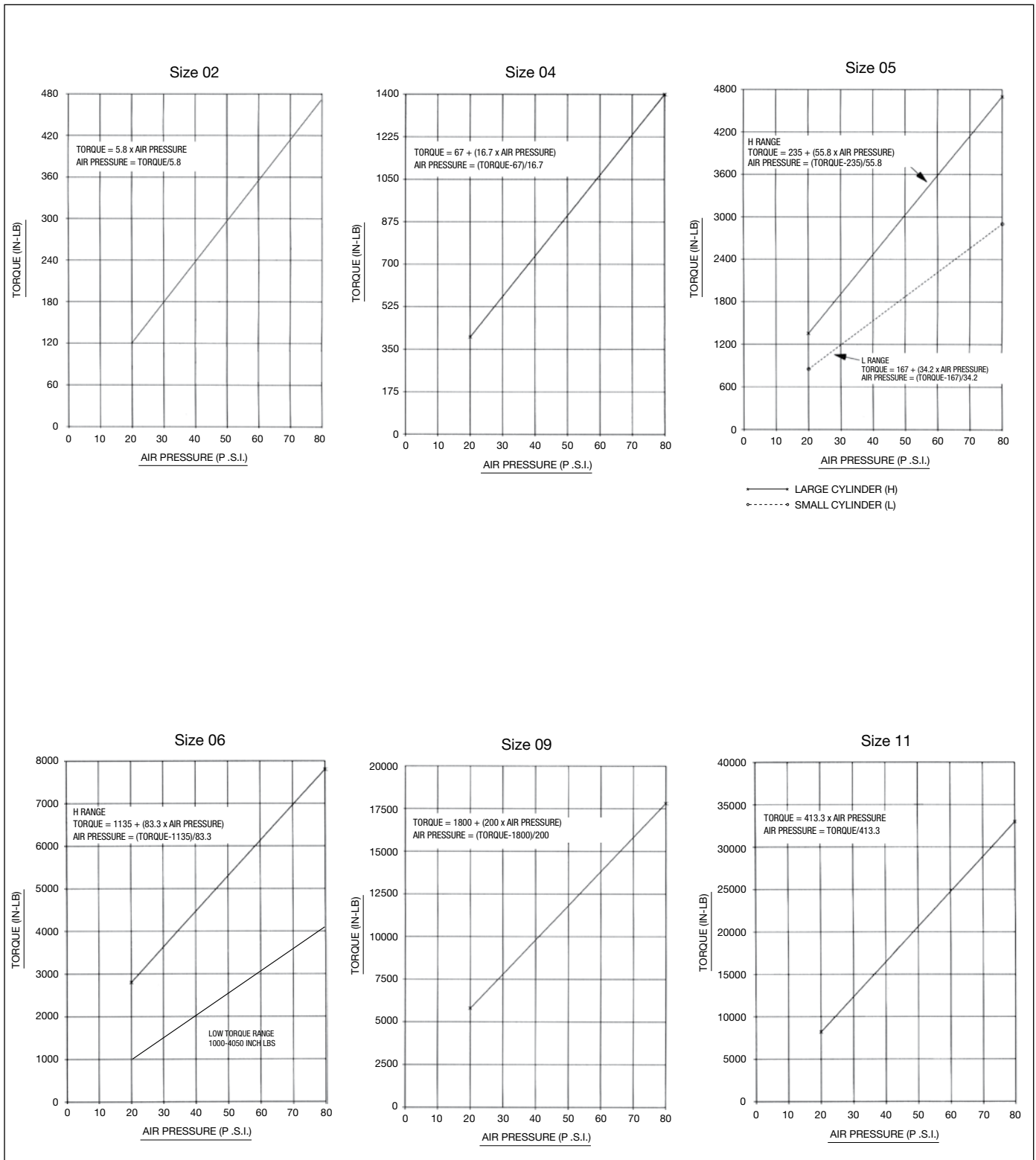



# Pneumatic Overload Disconnect Clutches PDC Series

---



## Section Contents

FEATURES .....	64
OPERATING PRINCIPLES .....	64
SELECTION .....	65
HOW TO ORDER.....	65
DIMENSIONS .....	66

# Pneumatic Overload Disconnect Clutches PDC Series

## Features

- “In-Flight” torque control offers precise pneumatic torque control
- Nickel plated and stainless steel exterior for superior corrosion resistance
- Completely sealed design
- Remotely adjustable for starting and overrunning loads
- Accurate and dependable disconnection, +/- 5% of torque setting
- Single position ball detent
- Provides maximum radial capacity, eliminating sprocket mounted bearings
- Dual radial ball bearings
- Internal valve
- Through shaft design
- Bi-directional operation
- Single position indexing
- Automatic reset
- Limit switch actuation mechanism
- Clamp collar for secure mounting
- Hardened parts for long clutch life
- Sealed from environmental contamination

The Boston Gear PDC Series Pneumatic Torque Limiting Disconnect Clutch is unique from other pneumatic clutches on the market today. Along with providing the expected protection from overloads in your equipment, it also allows the rotation of the two halves when the air is off and exhausted from the clutch.

The PDC clutches are completely sealed from the atmosphere and other harmful contaminants and all exterior surfaces are nickel plated for corrosion resistance and wash down service. Angular contact ball bearings are used in the units to provide added thrust capacity. Since many of these clutches are used with timing belt pulleys or sprockets, we have designed the unit with two radial ball bearings to provide support to the pulley or sprocket.

## Operating principles

The Boston Gear PDC Series Pneumatic Disconnect Clutch is a ball detent air actuated device. It has been designed to provide accurate and dependable torque overload protection for mechanical power transmission equipment. It has also been designed to provide a remote disconnection of the drive when the air supply is removed. The following diagram demonstrates the engaged and disengaged functions.

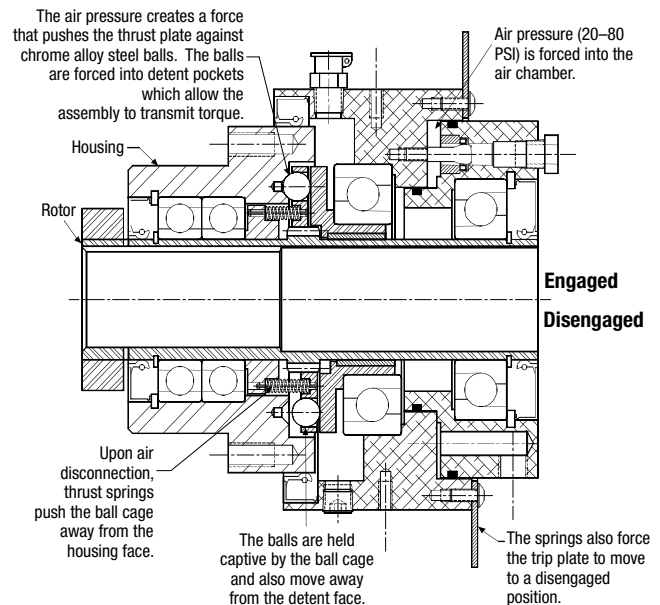

The top half of the view shows the unit in an engaged condition. 20 to 80 psi of shop air is forced into the air chamber. That air pressure exerts a force on a hardened thrust plate that pushes against six chrome alloy steel balls. The balls are forced into detent pockets, which allow the assembly to transmit torque. Increasing or decreasing the air pressure remotely controls precision “in flight” torque adjustment. The machinery can still be in operation when the torque rating is being adjusted. When a torque overload occurs, the housing and rotor rotate independently of each other. The balls roll out of their detents and a limit switch actuating plate moves forward to trip a limit switch and signal a torque overload condition. The drive should be shut down immediately and the source of the overload determined and cleared. To re-engage the clutch, re-apply the air pressure and jog the drive until the clutch engages. The PDC Series is a single position device. The unit will re-engage every 360° in the same location every time.

The bottom half of the view shows the unit in a disengaged condition. When air is disconnected, internal springs push the ball cage away from detent face of the housing. The balls are held captive by the ball cage so they also move away from the detent face. At this point, the unit is free to rotate in a disengaged condition. The main components that transmit torque are not in contact with each other.

# Pneumatic Overload Disconnect Clutches PDC Series

## Selection

- Determine overload release torque by one of these methods:
  - Use the torque formula with horsepower and RPM specific to the selected clutch location. A service factor may be required for high inertia starts, reversing or peak load conditions, (refer to Page 98 for service factor information. For average applications, a service factor "SF" of 1.25 is recommended):
 
$$\text{Torque (Lb. In.)} = \frac{\text{HP} \times 63025}{\text{RPM}} \times \text{SF}$$
  - Determine the "weak link" in the drive train, (i.e. chain, reducer, belt or shaft). Select an overload release torque that is below the "weak link's" maximum torque rating.
  - Physically measure the drive torque with a torque wrench and size accordingly.
- Determine the bore size:
  - Shaft size at the clutch location determines the clutch bore.
- Refer to the Basic Selection Chart for the appropriate clutch size. Determine the approximate start-up and running air pressures for the application.
- Refer to Pages 66 and 67 for ratings, dimensions and types.
- Refer to Part Numbering System to complete selection.

## Basic Selection Chart

Clutch Size	Max.* Bore (In.)	Torque Code	Torque Range (Lb.-In.)	Max. RPM
04	1.1875	H	300-1,700	1,800
05	1.7500	H	820-4,000	1,800

\*Larger bores may require flat keys (supplied with unit)

Style F is used where full shaft length is available.

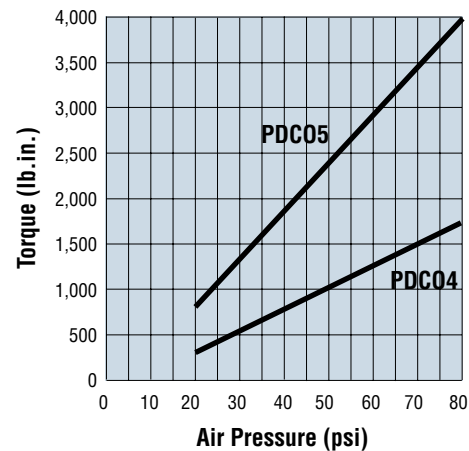
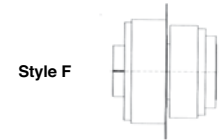

## PDC Series Part Numbering System

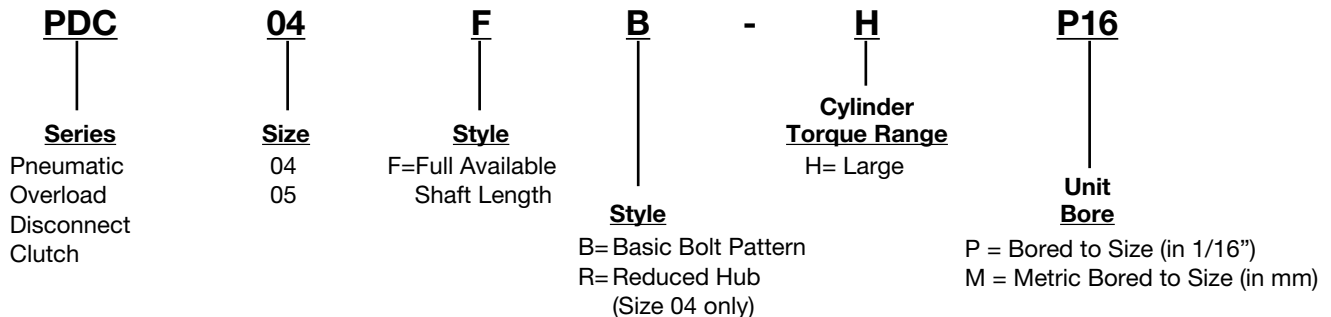

## How to Order

When ordering a PDC Series Overload Clutch, please include code letters/numbers for series, size, type, torque range, and unit bore.

### Example:

Required Size 04 PDC series Overload Clutch, full available shaft length, basic mount, large torque range with a one inch bore.

**PDC** **04** **F** **B** - **H** **P16**

# Pneumatic Overload Disconnect Clutches PDC Series

## Style F

### Type B Basic Hub Design

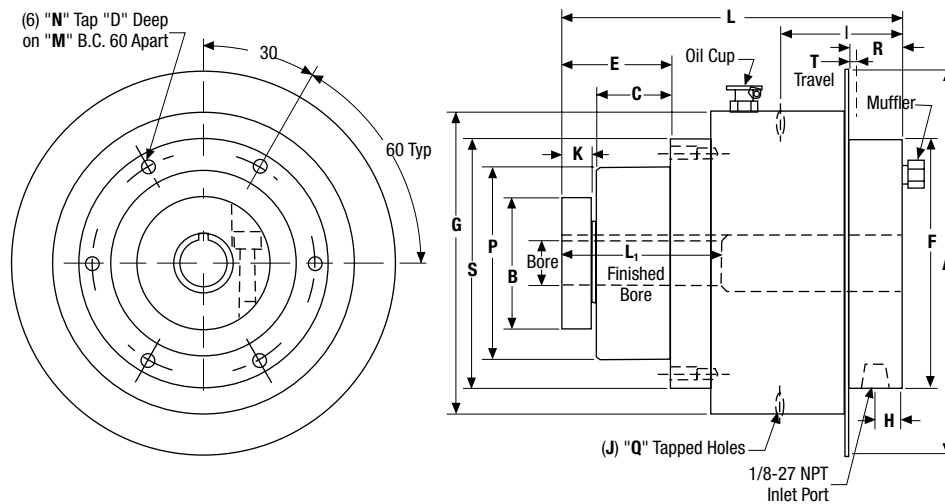

All Dimensions in Inches

Clutch Size	A	B	C	D	E	F	G	H	I	J	K
04	7.00	2.38	1.36	.63	2.00	4.67	5.50	.34	2.20	3	.56
05	8.00	3.38	1.14	.94	1.98	5.92	6.58	.50	2.20	4	.75

Clutch Bores

Clutch Size	L	L <sub>1</sub>	M	N	P +.000/- .002	Q	R	S	T
04	6.20	2.70	4.062	5/16-18	3.500	1/4-20	.95	4.53	.13
05	7.18	3.22	4.750	3/8-16	4.125	10-24	1.16	5.25	.15

Clutch Size	Bores (inch)	
	Max. (1)	Max. (2)
04	1.1250	1.1875
05	1.6250	1.7500

Refer to Page 96 for a complete list of bore codes.

- (1) Square Key
- (2) Flat Key

Refer to Page 65 for ordering information

# Pneumatic Overload Disconnect Clutches PDC Series

## Style F

### Type R Reduced Hub Design

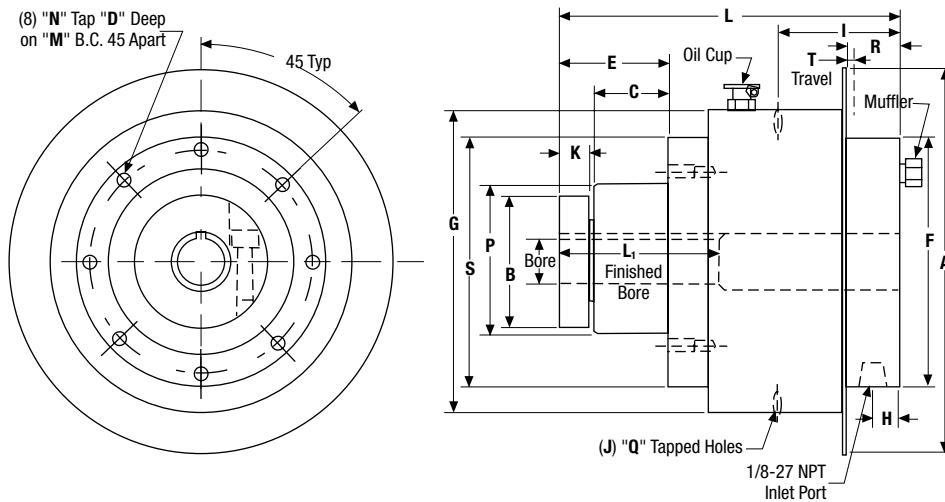

All Dimensions in Inches

Clutch Size	A	B	C	D	E	F	G	H	I	J	K
04	7.00	2.38	1.36	.56	2.00	4.67	5.50	.34	2.20	3	.56

Clutch Bores

Clutch Size	L	L1	M	N	P +.000/-0.002	Q	R	S	T
04	6.20	2.70	3.312	8-32	3.000	1/4-20	.95	4.53	.13

Clutch Size	Bores (inch)	
	Max. (1)	Max. (2)
04	1.1250	1.1875

Refer to Page 96 for a complete list of bore codes.

- (1) Square Key
- (2) Flat Key

Refer to Page 65 for ordering information

# Pneumatic Overload Disconnect Clutches

## Torque Limiter Application Data

Fax To 800-816-5608

Please select your product intent below and provide as much application information as possible.

### 1. Application:

- New
- Existing
  - Replacement Model # \_\_\_\_\_

### 2. Power transmission requirements at clutch location:

- RPM \_\_\_\_\_
- Limiting Torque Level \_\_\_\_\_

### 3. Type:

- Mechanical (Spring Loaded)
- Pneumatic

### 4. Type:

- Fully Automatic Re-Engagement
- Manual (Free Wheeling)
- Semi Automatic (ORC model only)

### 5. Method of Torque Transmission:

- Flexible Coupling
  - Rigid Coupling
  - Sprocket Mount
- Sprocket Size and Tooth Count \_\_\_\_\_

### 6. Bore Size:

- Sprocket Mount (Clutch Bore) \_\_\_\_\_
- Coupling Mount (Clutch Bore) \_\_\_\_\_  
(Coupling Bore) \_\_\_\_\_

### 7. Shut Down Method:

- Prox Plate
- Pin Style (ORC only)
- None Required

Name: \_\_\_\_\_

Phone # \_\_\_\_\_

Fax # \_\_\_\_\_

Company \_\_\_\_\_

E-Mail \_\_\_\_\_

Use the space below to note any relevant application data or to detail your question.

\_\_\_\_\_

\_\_\_\_\_

\_\_\_\_\_

\_\_\_\_\_

\_\_\_\_\_

\_\_\_\_\_

\_\_\_\_\_

\_\_\_\_\_

\_\_\_\_\_

\_\_\_\_\_

\_\_\_\_\_

\_\_\_\_\_

\_\_\_\_\_

\_\_\_\_\_

\_\_\_\_\_

\_\_\_\_\_

# Varitorque Pneumatic Overload Clutches VOR Series

---



## Section Contents

FEATURES .....	70
OPERATING PRINCIPLES .....	70
SELECTION.....	71
HOW TO ORDER.....	71
RATINGS AND DIMENSIONS .....	72
GENERAL INFORMATION .....	73

# Varitorque Pneumatic Overload Clutches VOR Series

## Features

- “In Flight” torque control. Precise torque control adjustable for starting and overrunning loads
- Single positioning for re-engagement at the exact cycle point at which it released
- Torque accuracy within  $\pm 5\%$
- Bi-directional operation
- Electroless nickel finish
- Six point drive engagement
- Automatic disconnect
- Deublin flange mounted air union
- Automatic switch actuating plate for instantaneous remote detection of overload condition
- Completely enclosed for “dirty” applications
- Pressure lubrication
- Positive split locking collar for secure shaft mounting
- Operates on static air pressure (20-80 psi), no elaborate air systems required

## Operating Principles

### Air Union

The air pressure supplied to the clutch enters through the hex steel rotor of the Deublin air union. When the VOR Series VariTorque is engaged and operating, the union rotor is the only stationary part. The union housing rotates on a double row ball bearing protected by dirt-tight seals. A spring-loaded carbon micro-lapped seal prevents air leakage between the rotor and housing of the union. The air passes through the union housing into the cylinder assembly of the VariTorque.

### Cylinder Assembly

Air pressure acts against the surface area of the piston exerting a force to move the piston against the pressure pins. Resulting torque ranges are developed by different size piston surface areas of the two cylinder sizes, (L-small, H-large).

The switch actuating plate moves with the piston. It is directly connected to the piston through the cylinder housing via trip pins and trip plate bolts. The plate’s lateral motion can be used to actuate a limit switch signaling an overload condition.



The valve assembly located through the piston serves two purposes. The first is to provide the single position engagement of the clutch. The piston will not be energized until the valve is seated in its cam seat located on the end of the rotor. This ensures that the rotor and cylinder-housing assembly always engage in the same relative position. The second purpose of the valve assembly is to relieve cylinder air pressure by allowing it to escape through the air exhaust muffler upon overload.

### Piston Springs

Once the valve is seated in its single home position, the clutch can be engaged. Air pressure forces the piston against the three piston springs. These springs serve to move the piston and switch actuating plate out when the clutch overloads or the air pressure is shut off to the clutch.

### Housing Assembly

The force from the piston is transmitted to six pressure pins. Six pawls equally spaced around the rotor are forced by the pressure pins to engage into six notches in the rotor barrel. The pressure pins, pawls and rotor are made of alloy steel and are electroless nickel plated for long life.

When the set torque limit in the VariTorque is exceeded, the pawls are forced out of the notches in the rotor barrel. They in turn push the pressure pins and piston. When the rotor turns in relation to the housing-cylinder assembly, the valve rides up the ramp of the cam seat and relieves the cylinder air pressure. The rotor now can rotate freely, independent of the housing assembly on two sealed ball bearings.



# Varitorque Pneumatic Overload Clutches VOR Series

## Selection

- Determine the overload release torque by one of these methods:
  - Use the torque formula with horsepower and RPM specific to the selected clutch location. A service factor may be required for high inertia starts, reversing or peak load conditions, (refer to Page 98 for service factor information. For average applications, a service factor "SF" of 1.25 is recommended):
 
$$\text{Torque (Lb. In.)} = \frac{\text{HP} \times 63025}{\text{RPM}} \times \text{SF}$$
  - Determine the "weak link" in the drive, (i.e. chain, reducer, belt or shaft). Select an overload release torque below the "weak link's" maximum torque rating.
  - Physically measure the drive torque with a torque wrench and size accordingly.
- Determine the bore size and keyway.
- Determine the approximate start-up and running air pressures for the application.
- Refer to the Basic Selection Chart for the appropriate clutch size.
- Refer to Page 72 for ratings and dimensions.
- Refer to Page 97 for recommended mounting locations.

**Figure 1**  
Air pressure and torque capacity

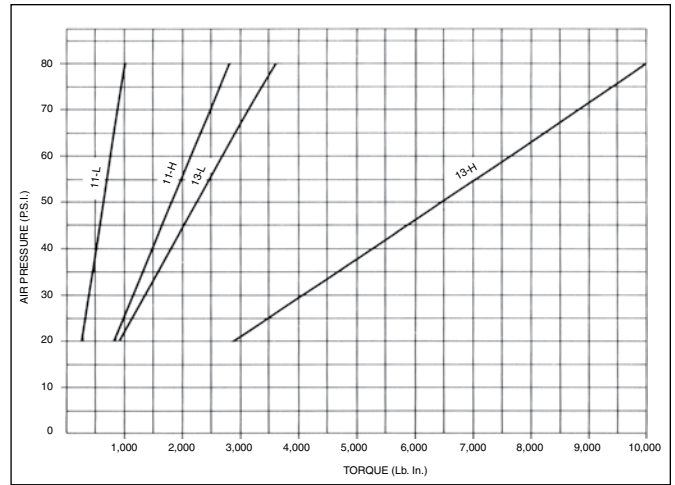

**Basic Selection Chart**

Clutch Size	Maximum Bore (In.)*	Torque Code	Torque Range (Lb. In.)	Maximum RPM
11	1.3125	L	250-1,000	1,000
	1.2500	H	800-2,800	
13	2.1875	L	900-3,600	1,000
	2.0000	H	2,800-10,000	

\*Larger bores may require flat keys (supplied with unit).

## VOR Series Part Numbering System

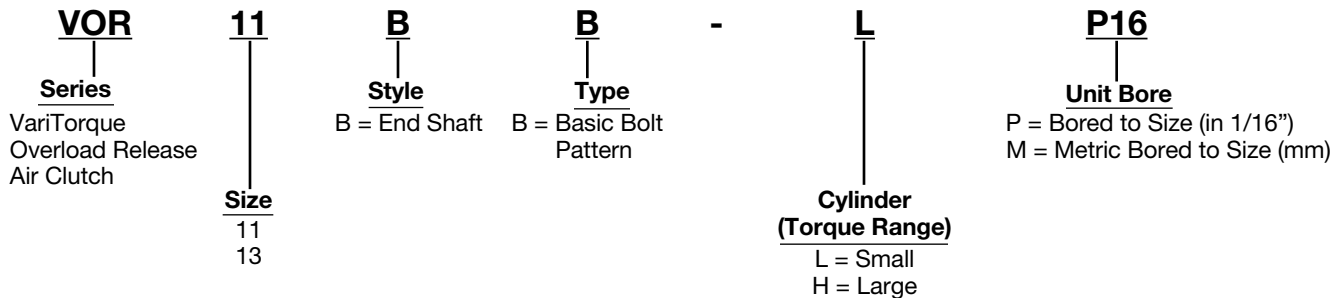

## How to Order

When ordering a VOR Series VariTorque Overload Clutch, please include code letters/numbers for series, size, style, type, torque range, and unit bore.

### Example:

Required Size, 11 VOR Series Overload Clutch, end shaft mount, basic type, small torque range, with a one inch bore:

VOR 11 B B - L P16

# Varitorque Pneumatic Overload Clutches VOR Series

## Style B

### Type B Basic Sprocket Mounting

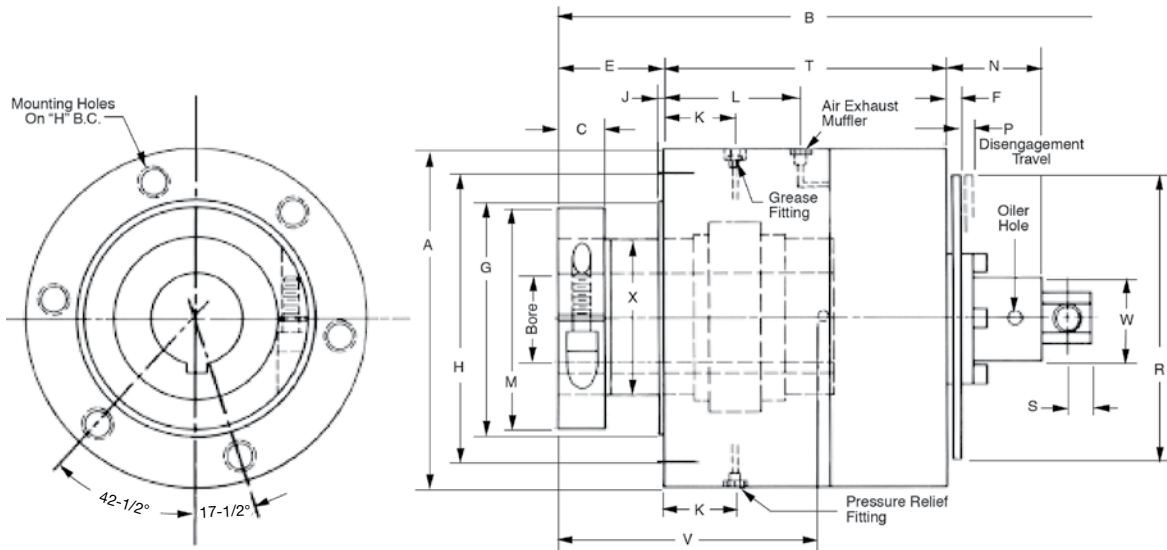

All Dimensions in Inches

Clutch Size	A	B	C	E	F	G ±.001	H Bolt Center	J	K	L	M	N	P	R	S	T	V	W	X +.0000 -.0005	Mounting Holes	
																				Qty.	Thread Size
11	4.75	9.03	.68	1.50	.21	2.748	3.500	.06	0.96	1.69	2.75	2.19	.13	4.75	.44	4.42	3.03	1.62	1.7722	6	5/16-18
13	6.50	10.19	.87	2.00	.21	4.498	5.500	.06	1.38	2.62	4.00	1.81	.16	6.50	.44	5.44	4.47	1.62	2.7565	6	5/8-11

### Ratings

Clutch Size	Torque Code	Torque Range (Lb.-In.)	Max. RPM	Air Inlet (NPT)	WR2 (Lb.-In.2)	Weight (Lbs.)
11	L	250-1,000	1,000	1/4	45.7	17
	H	800-2,800			46.5	18
13	L	900-3,600	1,000	1/4	197	39
	H	2,800 - 10,000			212	41

### Clutch Bores

Clutch Size	Torque Range	Bores (inch)	
		Max. (1)	Max. (2)
11	L	1.1875	1.3125
	H	1.1875	1.2500
13	L	1.7500	2.1875
	H	1.7500	2.0000

Refer to Page 96 for a complete list of bore codes.

- (1) Square Key
- (2) Flat Key

Refer to Page 71 for ordering information.

# Varitorque Pneumatic Overload Clutches

## General Information

### Limit Switch

In the layout in Figure 2 the limit switch should be wired in its normally closed condition. The switch is used to open the circuit to the motor during a torque overload condition. The switch should be wired in parallel with the JOG button so the drive may be started in the event the VariTorque clutch has stopped with the limit switch circuit in an open state.

### Air Controls

The HIGH pressure regulator should be set at a pressure just HIGH enough to permit the VariTorque clutch to overcome any momentary overload torques caused during the machine's start-up and stopping period.

The LOW pressure regulator should be set at a pressure just LOW enough to permit the VariTorque clutch to overcome the normal operating torques caused during the machines running period and to permit a crisp and positive re-engagement of the VariTorque clutch should an overload occur.

### Indirect Drives

The VariTorque overload release air clutch is utilized in conjunction with chain sprockets or belt driven sheaves. For chain and sprocket applications smaller than those shown in the table below or belt driven sheave applications, consult with the factory. In most cases, a minor modification of the VariTorque design or the sprocket/sheave will permit usage.

### Special Finishes

All VariTorque clutches are supplied with an electroless nickel finish. Special coatings, finishes or paints are also available.

### Custom Variations

- Sprockets or sheaves supplied and mounted
- Dimensional changes (i.e. overall length, actuating plate diameters)
- Bores and keyways (i.e. metric, non-standard)
- Special adaptations

Figure 2

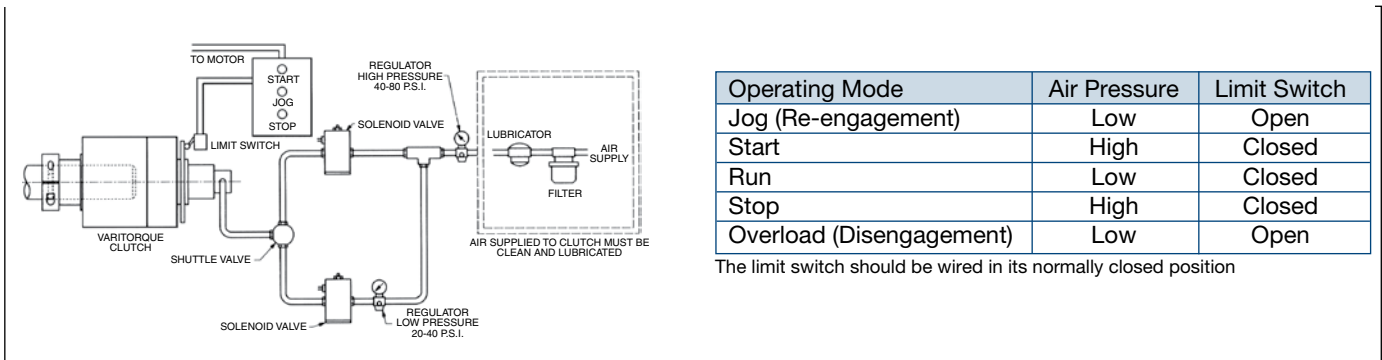

Operating Mode	Air Pressure	Limit Switch
Jog (Re-engagement)	Low	Open
Start	High	Closed
Run	Low	Closed
Stop	High	Closed
Overload (Disengagement)	Low	Open

The limit switch should be wired in its normally closed position

Refer to Boston Gear's Fluid Power Products Catalog for air preparation and control products.

### Minimum Acceptable Plate Sprocket Mounts

Clutch Size	Chain Size and Pitch									
	#35 3/8 Pitch	#40 1/2 Pitch	#41 1/2 Pitch	#50 5/8 Pitch	#60 3/4 Pitch	#80 1 Pitch	#100 1-1/4 Pitch	#120 1-1/2 Pitch	#140 1-3/4 Pitch	#160 2 Pitch
11	45	34	35	28	24	19	16	14	12	—
13	60	45	45	36	31	24	20	17	16	14

Boston Gear will also supply and mount sprockets or sheaves, as specified, for a complete package.

# Varitorque Pneumatic Overload Clutches VOR Series

## Torque Limiter Application Data

Fax To 800-816-5608

Please select your product intent below and provide as much application information as possible.

### 1. Application:

- New
- Existing
  - Replacement Model # \_\_\_\_\_

### 2. Power transmission requirements at clutch location:

- RPM \_\_\_\_\_
- Limiting Torque Level \_\_\_\_\_

### 3. Type:

- Mechanical (Spring Loaded)
- Pneumatic

### 4. Type:

- Fully Automatic Re-Engagement
- Manual (Free Wheeling)
- Semi Automatic (ORC model only)

### 5. Method of Torque Transmission:

- Flexible Coupling
  - Rigid Coupling
  - Sprocket Mount
- Sprocket Size and Tooth Count \_\_\_\_\_

### 6. Bore Size:

- Sprocket Mount (Clutch Bore) \_\_\_\_\_
- Coupling Mount (Clutch Bore) \_\_\_\_\_  
(Coupling Bore) \_\_\_\_\_

### 7. Shut Down Method:

- Prox Plate
- Pin Style (ORC only)
- None Required

Name: \_\_\_\_\_

Phone # \_\_\_\_\_

Fax # \_\_\_\_\_

Company \_\_\_\_\_

E-Mail \_\_\_\_\_

Use the space below to note any relevant application data or to detail your question.

---

---

---

---

---

---

---

---

---

---

---

---

---

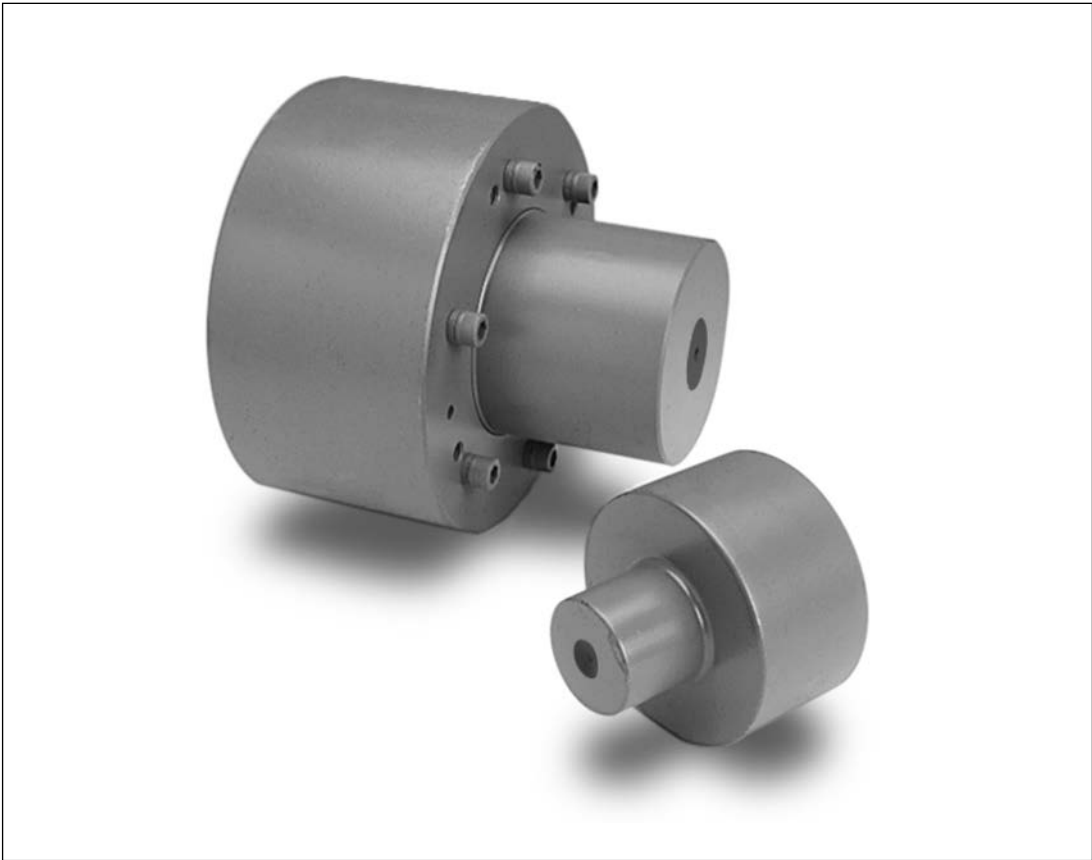

### Section Contents

- CENTRIC CENTRIFUGAL CLUTCHES CCC SERIES
  - FEATURES ..... 76
  - OPERATING PRINCIPLES ..... 77
  - SELECTION ..... 77
  - TYPE A STANDARD ..... 79
  - TYPE AVL VERTICAL LIFT OUT ..... 80
  - TYPE H PULLEY MOUNT ..... 81
  - AVAILABLE TYPES ..... 82
  - OVERLOAD DETECTION ..... 82
- NLS™ CENTRIFUGAL CLUTCHES
  - OPERATING PRINCIPLES ..... 83
  - AVAILABLE STYLES ..... 83
  - STEP BY STEP SELECTION ..... 84
- SURE-GRIP BUSHINGS
  - DIMENSIONS ..... 90
  - BORE AND KEYSEAT DIMENSIONS ..... 91
  - SELECTION GUIDE ..... 94

# Centric Centrifugal Clutches CCC Series

## Features

- Automatic engagement and disengagement
- Delayed engagement produces a “no load start”
- No slippage at full running speed
- Controlled soft-start acceleration
- 100% efficient at rated speed
- Standard, spring control, and deep pocket models
- Protection against shock loads during start-up
- Custom clutches can be designed to be RPM limiters or a “brake” on a runaway system

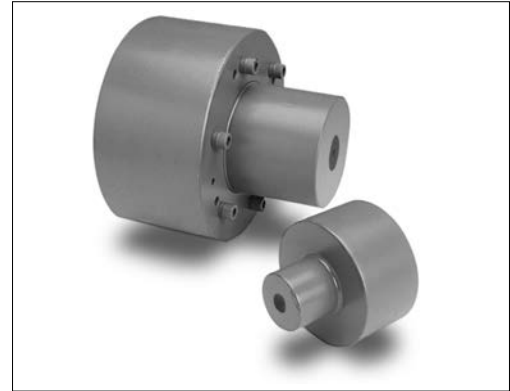

## Why are they used?

The Boston Gear Centric Centrifugal Clutch offers many advantages in motor and engine drive applications. Utilizing the centrifugal clutch enables the selection of normal torque motors for running loads rather than the selection of high torque motors for starting loads. The centrifugal clutch also sharply reduces the motor starting current requirements and heat losses inherent in the direct starting of a drive. This adds up to reduced power factors, greater efficiency and therefore, greater economy in motor drives.

When used with engine drives, the spring controlled centrifugal clutch allows the engine to warm up before starting the load or to stand by at an idling speed. Thus the spring controlled centrifugal clutch is used to great advantage in such applications as dual drives and engine driven pumping systems. This style clutch can also be used with turbines where a warm up period is necessary.

On any drive, the Boston Gear Centric Centrifugal Clutch provides protection against the shock loads which occur in the starting of a rigidly coupled drive. In many cases these loadings are capable of seriously damaging components of the drive and often expensive safety factors have to be designed into the machinery to protect against these loadings. The use of a centrifugal clutch eliminates these possibilities.

The use of a Boston Gear Centric Centrifugal Clutch allows the designer of a particular drive complete flexibility in clutch selection as each clutch is fabricated to order. Friction shoes of specific weights are custom designed therefore, any capacity within a particular clutch size can be obtained. The same holds true in the case of the spring controlled clutch. This style of clutch is designed to provide the specific engagement or disengagement speeds required by a specific application.

### Free Engagement Standard Style



### Spring Controlled Style



## CCC Series Part Numbering System

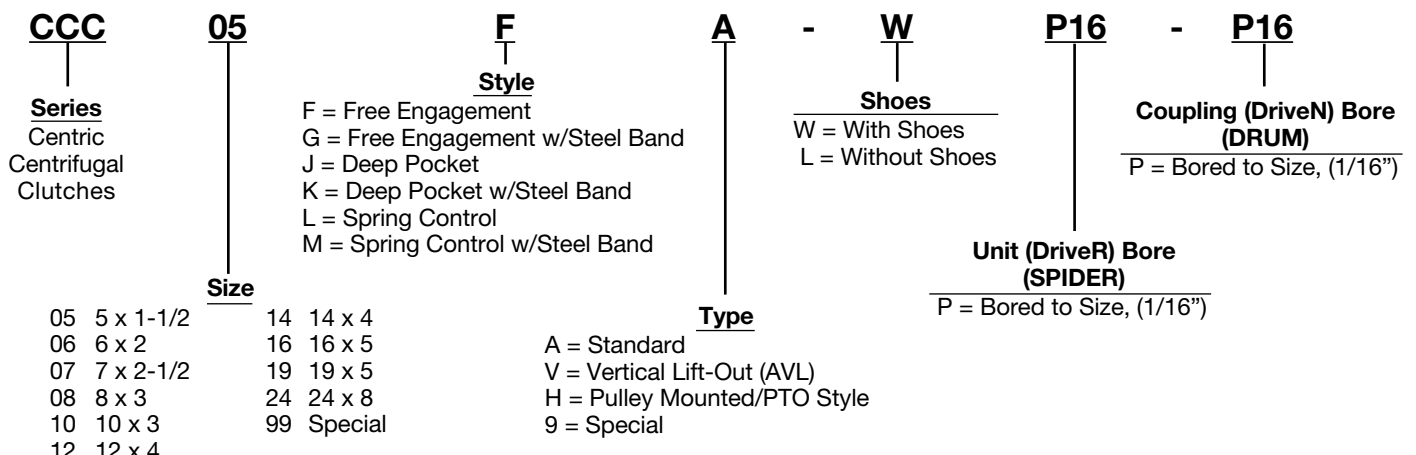

## Operating Principles

The Boston Gear Centric Centrifugal Clutch utilizes two basic force principles in its operation, centrifugal force and friction force. Centrifugal force is that force which tends to pull a rotating body away from its center of rotation. Friction force exists between any two bodies in contact where one of the bodies is trying to move relative to the other body.

Figure 1, a face view of a centrifugal clutch, shows the basic components of the device. The driver half or spider is mounted to the motor or engine shaft and the driven half is connected to the load either directly or by means of some indirect drive arrangement. The friction shoes are the connective element between the driver and driven.

When the drive is set in motion, the spider and the shoes start to rotate. The spider imposes a driving force ( $F_3$ ) on the friction shoe as shown in Figure 2. The centrifugal force ( $F_1$ ) developed by the rotary motion of the friction shoe impresses it against the drum creating a frictional force ( $F_2$ ) between the shoe and the drum.

As the drive increases in speed, the centrifugal force increases and thereby frictional force increases. When the frictional force reaches sufficient magnitude, it overcomes the resistance of the load, and the clutch drives. At full load speed, the shoe is "locked" firmly against the drum and no slippage occurs.

In engine and turbine applications, where it is necessary to "warm up" before attempting to drive a load, a spring controlled clutch is utilized. Figure 3 shows a typical spring control shoe. Here, a flat spring is placed over pins which run through the base of the shoe. This spring is retained in slots which are milled in the legs of the spider creating additional forces ( $F_s$ ) which are applied to the friction shoes. The thickness of the spring utilized determines at what speed the particular drive may idle while warming up. At this idling speed the centrifugal force ( $F_1$ ) developed by the rotation is not of sufficient magnitude to overcome the total spring force ( $2F_s$ ) acting in the opposite direction on the friction shoe. As the speed of the drive increases above the point at which the spring forces ( $F_s$ ) and the centrifugal force ( $F_1$ ) are balanced, the shoe is pressed against the drum creating a friction force. The operation from this point on is as described above.

## Selection

There are an infinite number of combinations of Boston Gear Centric Centrifugal Clutches. While operating on the same basic principles, every clutch is designed to suit a specific customer application. To assure that the appropriate clutch is selected, please complete the Selection Guide on Page 94 and fax it to Boston Gear.

Upon receipt, our application engineering department will review your requirements and return the optimal Boston Gear Centric Centrifugal Clutch design along with its dimensional drawings.

Figure 1

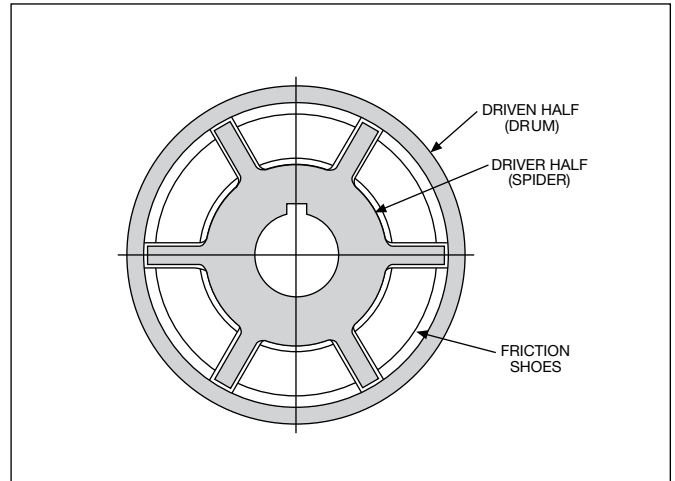

Figure 2

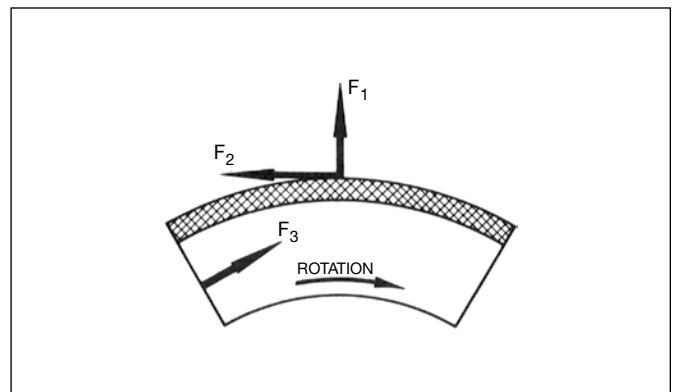
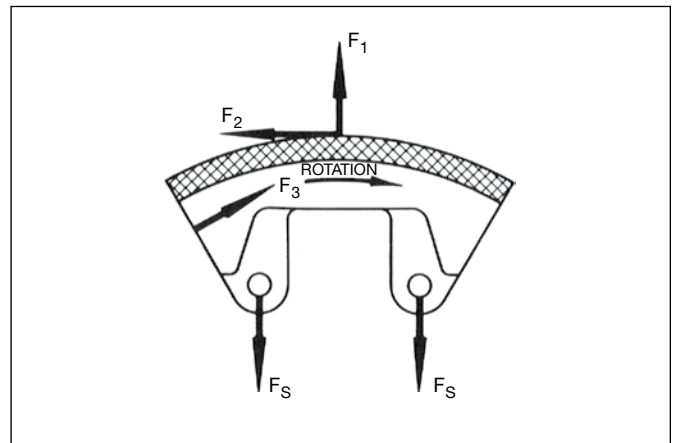

Figure 3



# Centric Centrifugal Clutches

## Available Styles

Boston Gear Centric Centrifugal Clutches are available for two basic applications: Styles F and J for electric motors and Style L for engines and turbines.

Standard Style F incorporates a shoe arrangement designed for electric motors, (Figure 4). As the motor comes up to speed, the outer friction shoes engage the driven half (the drum) and accelerate it. As it and the load come up to speed, the inner friction shoes engage the driver (the spider) locking up the drive.

**Figure 4**  
**Free Engagement Standard Style F/G**

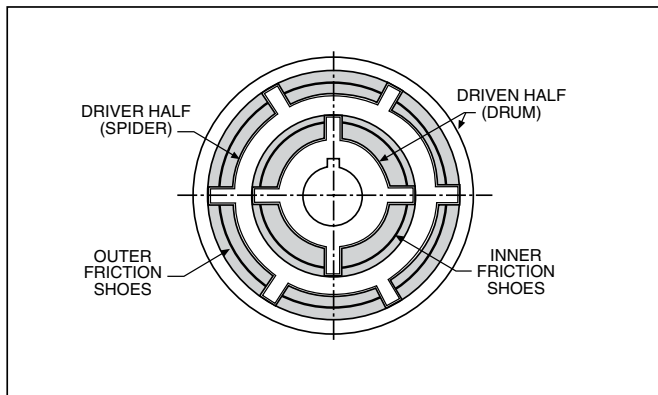

Where overload protection is required or greater capacity is needed in the drive, Style J containing deep pockets should be ordered, (Figure 5).

**Figure 5**  
**Deep Pocket Style J/K**

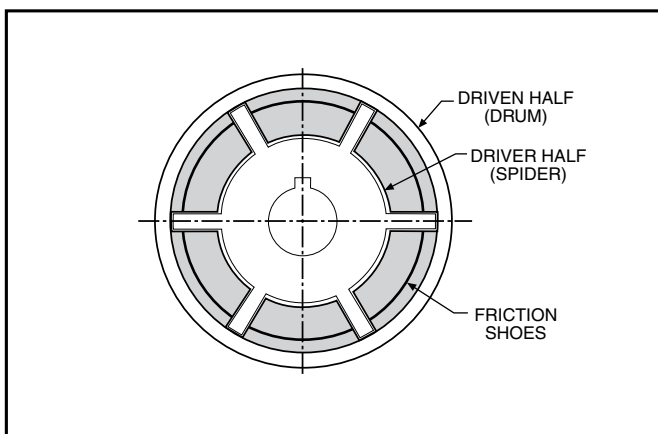

Style L incorporates a spring controlled shoe arrangement designed for engines, turbines, dual drives, or whenever a delayed engagement is desired, (Figure 6).

**Figure 6**  
**Spring Controlled Style L /M (Delayed Engagement)**

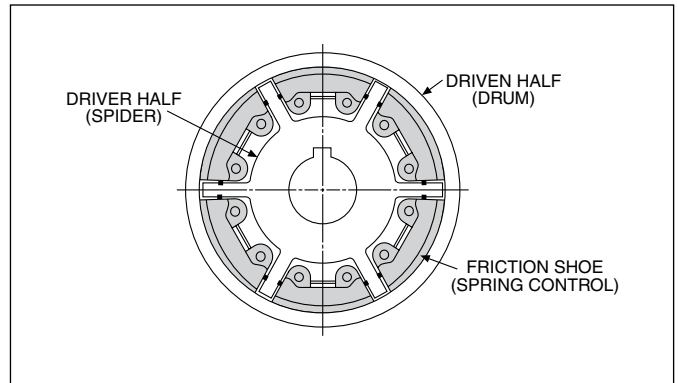

For applications where either high speeds or large horsepower conditions exist, Styles G, K and M may be provided. These styles are identical to the models shown in Figures 4, 5 and 6, however they also incorporate steel bands wrapped around the housing helping to reduce stress, (Figure 7).

**Figure 7**  
**Style F with Steel Band**

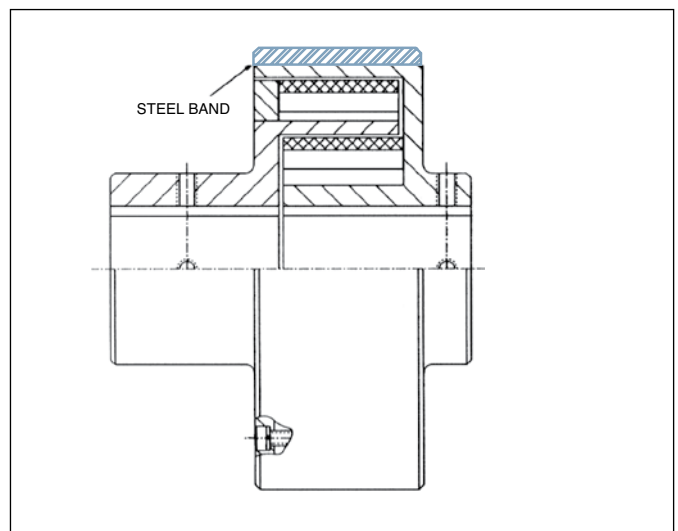



# Centric Centrifugal Clutches

## Type A Free Engagement Style and Spring-Controlled Centrifugal Clutches Bored to Size

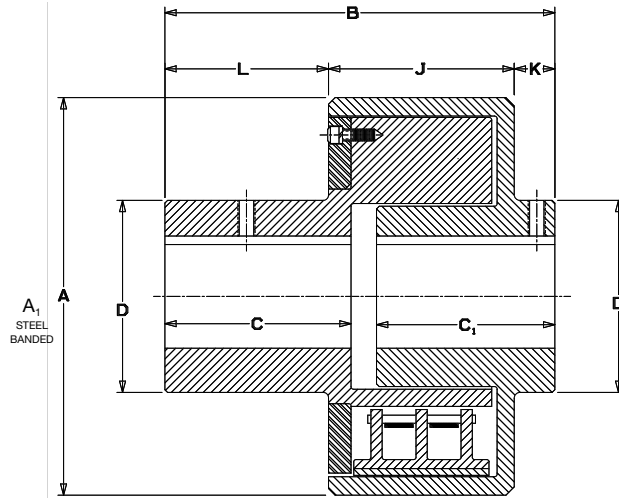

Clutch Coupling Sizes	Maximum Bore Inches	Minimum Bore Inches	Wt. in Lbs. with Max. Bore	DIMENSIONS IN INCHES									
				A	A <sub>1</sub> Steel Banded	B	C	C <sub>1</sub>	D	J	K	L	HP*
5 x 1-1/2	1-3/8	3/4	15	5-3/8	-	4-11/16	2-3/16	2-7/16	2-1/2	2-3/16	5/8	1-13/16	40
6 x 2	1-5/8	3/4	25	6-1/2	7-3/4	6-1/4	2-15/16	3-3/16	3	3-1/16	3/4	2-7/16	92
7 x 2-1/2	1-7/8	1	40	7-5/8	8-5/8	7-1/4	3-7/16	3-11/16	3-3/8	3-9/16	3/4	2-15/16	125
8 x 3	2-3/8	1-1/4	65	8-7/8	9-3/4	8-3/4	4-1/8	4-1/2	4-1/4	4-1/8	1	3-5/8	160
10 x 3	2-7/8	1-1/4	100	10-13/16	11-3/4	8-13/16	4-1/8	4-9/16	5-1/8	4-3/16	1	3-5/8	215
12 x 4	3-1/2	1-1/2	200	13-1/8	14	11-3/8	5-1/2	5-11/16	6-1/4	5-1/2	1	4-7/8	356
14 x 4	4-1/8	2	300	15-1/8	16	11-3/8	5-1/2	5-5/8	7-3/8	5-1/2	1	4-7/8	500
16 X 5	4-3/4	2-1/2	400	17-3/8	18-1/4	13-3/4	6-3/4	6-13/16	8-1/2	6-5/8	1	6-1/8	562
19 x 5	5-5/8	2-1/2	1000	20-1/2	21-1/2	14-3/16	7	7	9-3/4	6-7/8	1-1/16	6-1/4	1500
24 x 8	7	3	1315	26-1/2	26-1/2	20-3/16	10	10	12-1/2	9-7/8	1-1/16	9-1/4	2280

Max Angular Misalignment- 1/4°

Max Parallel Misalignment- .010"

\* The actual horsepower rating is largely dependent on RPM and may be higher or lower than the indicated HP. Contact engineering before finalizing clutch selection.

# Centric Centrifugal Clutches

## Type V Free Engagement and Spring-Controlled Vertical Liftout Centrifugal Clutches

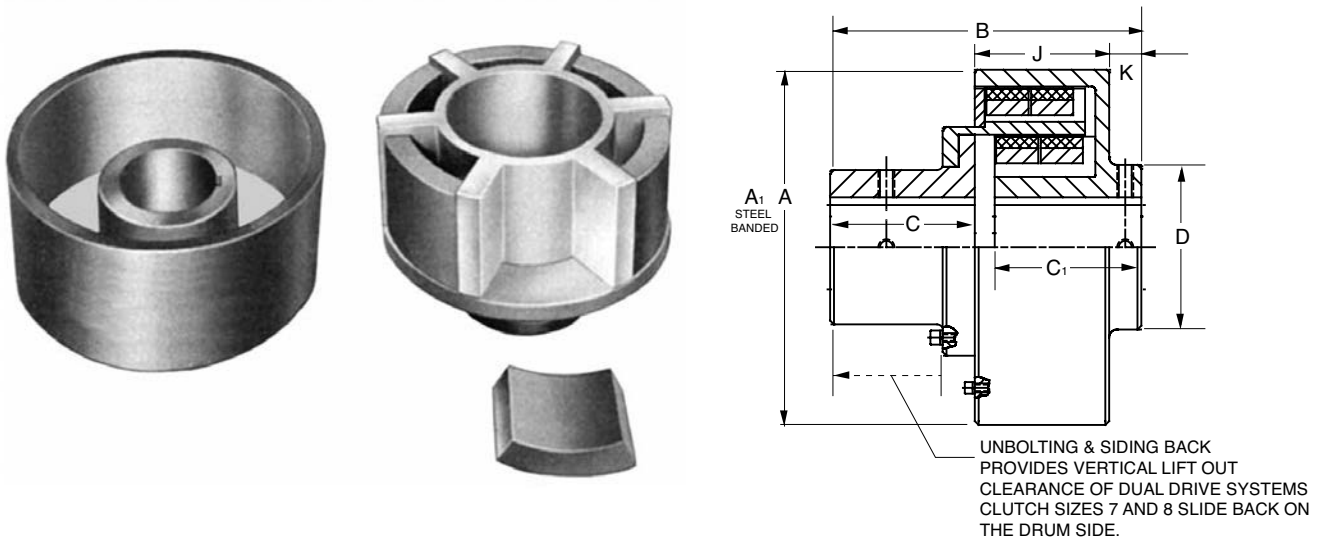

Clutch Coupling Sizes	Maximum Bore Inches	Wt. in Lbs. with Max. Bore	DIMENSIONS IN INCHES								
			A	A <sub>1</sub>	B	C	C <sub>1</sub>	D	J	K	HP**
7 x 2-1/2	2.375	40	7.62	8.62	8.25	4.12	4.00	3.93	4.00	3.25	125
8 x 3	2.875	55	8.83	9.75	9.50	4.62	4.75	4.68	4.75	3.75	160
10 x 3	2.625	100	10.81	11.75	9.75	4.50	4.56	5.12	4.19	1.00	215
12 x 4	3.00	200	13.12	14.00	12.31	5.75	5.68	6.25	5.50	1.00	356
14 x 4	3.50	325	15.16	16.00	12.31	5.75	5.68	7.38	5.50	1.00	450
16 x 5	4.75	400	17.38	18.25	14.68	7.00	6.80	8.50	6.62	1.00	562
19 x 5	5.00	900	20.50	21.50	15.00	7.00	7.00	10.00	8.87	1.06	1400
24 x 8	7.00	1350	26.50	26.50	21.81	10.68	10.00	12.00	9.94	1.06	2280

Max Angular Misalignment 1/4°  
 Max Parallel Misalignment .010"

\*\* The actual horsepower rating is largely dependent on RPM and may be higher or lower than the indicated HP. Contact engineering before finalizing clutch selection.

# Centric Centrifugal Clutches

## Type H Spring Controlled Pulley Mounted PTO Centrifugal Clutches Available as Shaft or Engine Mounted

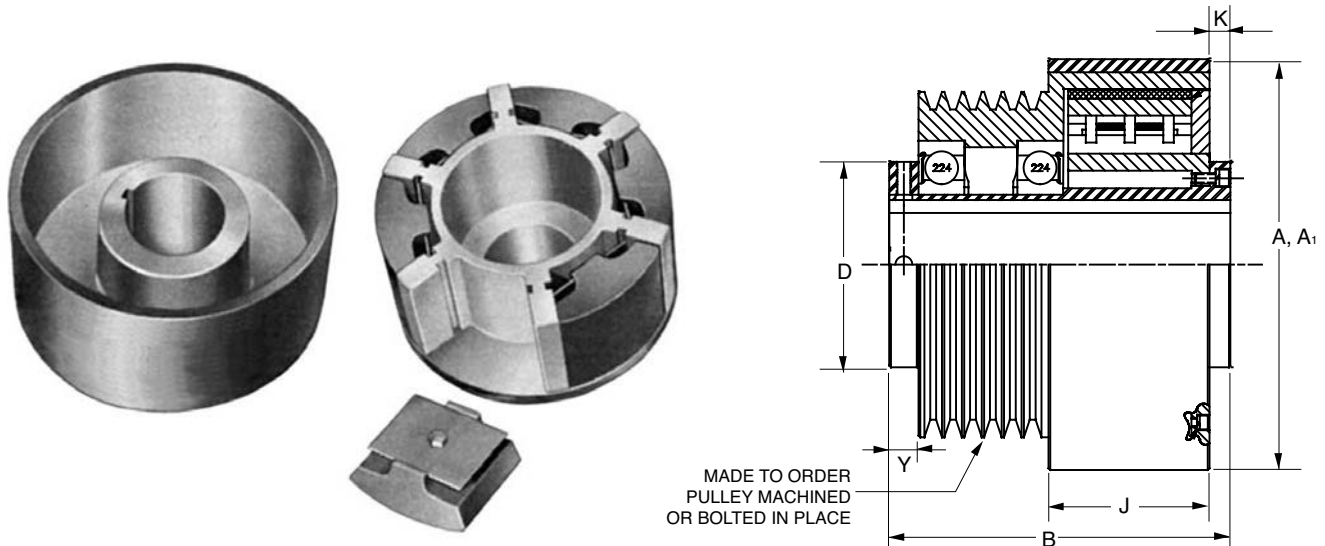

Clutch Coupling Sizes	Maximum Bore Inches	Typ. Grooves	A	DIMENSIONS IN INCHES						
				A <sup>1</sup>	B	D	J	K	Y	HP**
6 x 2	1.4375	2	6.56	7.50	5.43	2.62	3.68	0.0	.63	90
8 x 3	2.000	4	8.95	8.95	6.30	5.12	4.30	0.0	0.0	160
12 x 4	3.500	6	13.12	14.00	11.69	7.00	5.50	.75	1.0	350
16 x 5	4.500	8	17.38	18.25	15.32	8.50	6.62	1.70	1.0	560

\*\* The actual horsepower rating is largely dependent on RPM and may be higher or lower than the indicated HP. Contact engineering before finalizing clutch selection.

# Centric Centrifugal Clutches

## Available Types

Type A Centric Centrifugal Clutches are similar to standard coupling/clutch designs in that the installation and removal of the clutch requires horizontal clearance. This type of design may necessitate the relocation of other drive train components to achieve this clearance.

The Type V clutch is a modification of the basic Type A unit. This construction is utilized to a great advantage in direct drive applications where the equipment used is too heavy to be conveniently telescoped at assembly or disassembly. Figure 8 shows how either piece of equipment can be vertically lifted out of its assembled position. The Type V clutch construction allows the clutch spider to be slipped back over its own hub, completely clearing the clutch drum (see page 80). If a Type A construction had been used here, it would have been necessary to first move the pump horizontally in order to clear the drum and spider before a vertical lift could have been accomplished. This horizontal movement is often not convenient and sometimes impossible such as in certain dual drives and of course where space limitations exist.

**Figure 8**  
**Vertical Liftout Type V**

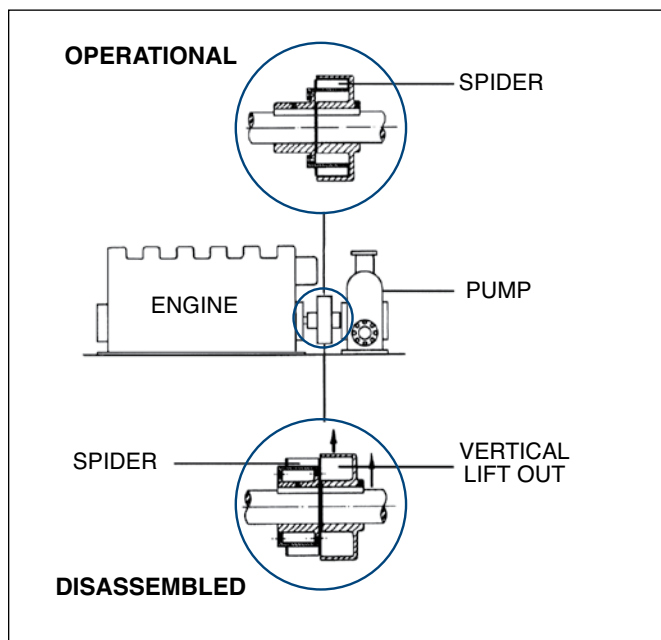

## Overload Detection

In Figure 9 a safety device is incorporated to indicate an overload condition. In such applications a centrifugal switch is utilized. The switch is set to trip below a certain critical RPM determined by the application, and in so doing, actuate a signal or shut down the drive. The illustration shows the most common method of using a centrifugal switch in conjunction with a Boston Gear centrifugal clutch. "A" groove sheaves are mounted on the driven member of the clutch and the centrifugal switch. These sheaves are of such a ratio as to allow the centrifugal switch to operate within its limits.

For example, a drive arrangement is set to turn at 1750 RPM. It is determined that the desired cut out speed for the application is at 1500 RPM. The centrifugal switch is set to trip at speeds below 750 RPM and normally will run at 875 RPM which, through a 2:1 ratio corresponds to the drive RPM of 1750.

In actual operation the drive is turning at 1750 RPM. An overload occurs in the driven machinery and the capacity of the clutch is exceeded. While the driver half is still turning at the 1750 RPM, the driven half is dragging due to the increased capacity and drops below the 1500 RPM speed. The switch is actuated by this decrease in speed and an alarm is sounded or the drive is shut down.

**Figure 9**

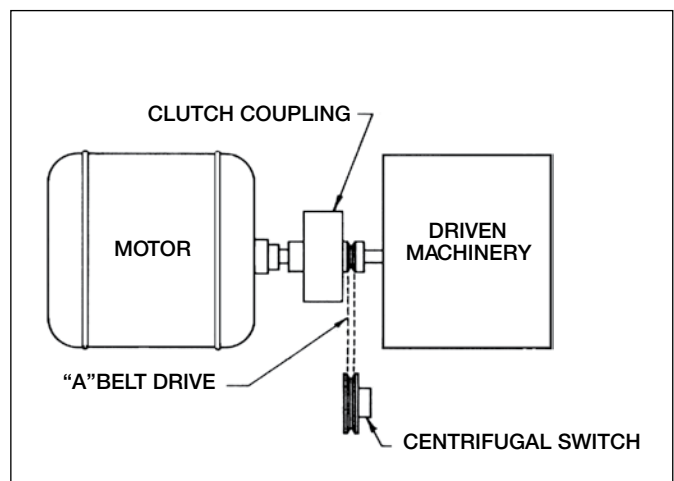

## Operating Principles

The NLS centrifugal clutch is a rugged time-proven unit which provides equipment protection and system overload protection. This is done by allowing the motor or other driving source to accelerate to operating speed without load and to slip automatically when overloaded. This clutch is available in a free (type A) and delayed engagement (type AD) model, also in various sizes to handle different horsepower capacities.

### TYPE A

#### Free Engagement

The shoes are a free floating part of the driving unit to which the power is applied. As the driver picks up speed, the shoes are forced outward by centrifugal force to make contact with the inside surface of the driven half. The shoes will make smooth contact and slip until the load reaches full speed. Both members then rotate as a unit with no slippage or power loss. Larger units have both inner and outer shoes.

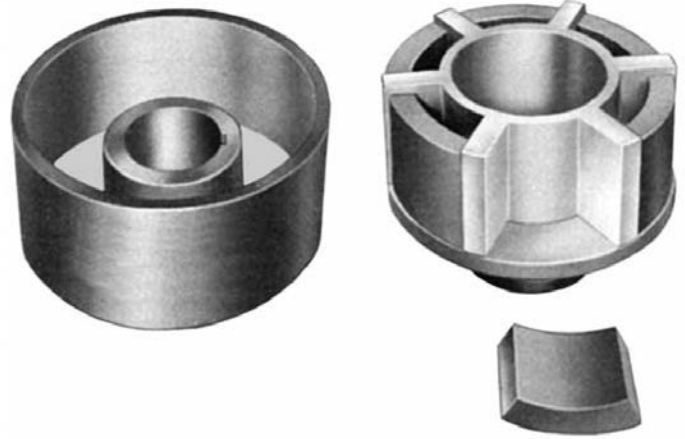

**TYPE A  
WITH ONE ROW OF SHOES**

### TYPE AD

#### Delayed Engagement (Spring Controlled)

Operating under the same principle as the type A unit, the type AD uses springs to hold the shoes out of engagement until the driver reaches a predetermined rpm. At this point centrifugal force, acting on the shoes, overcomes the spring force, allowing smooth engagement of the power source with the load. Because the shoes are out of engagement until the driver is above the predetermined speed, this unit is ideal for dual or stand-by drives as well as idling or warming-up engines.

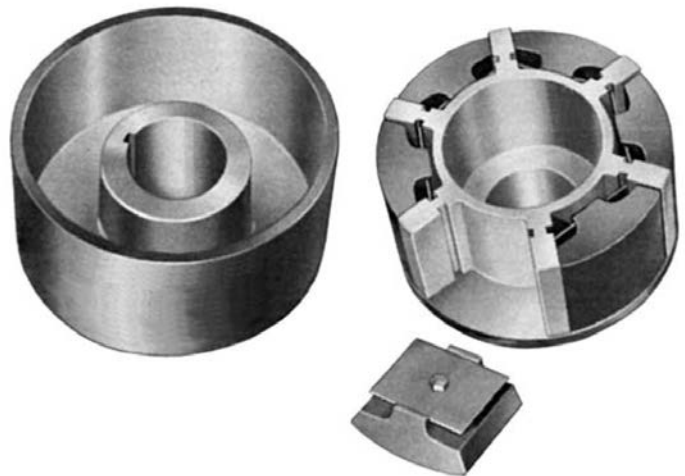

**TYPE AD  
FOR DELAYED ENGAGEMENT**

# NLS™ Centrifugal Clutches





## Easy Step by Step Selection Method

### Step #1

Determine HP and minimum driving RPM (also idle RPM if delayed engagement type is required).

### Step #2

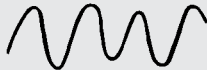
Using the service factor chart, determine the proper service factor based on the prime mover and driven equipment.

DRIVEN EQUIPMENT LOAD CLASSIFICATIONS				
	LIGHT STEADY LOADS Starting torque is equal to or slightly greater than running torque.	MODERATE LOADS High starting torque or above average running torque.	MEDIUM LOADS Starting torque is approximately double running torque.	HEAVY-DUTY LOADS High starting torque, shock loading, light torque reversals during drive.
				
	Centrifugal pumps, uniformly loaded conveyors, light-duty fans and blowers, liquid mixers and agitators, centrifugal compressors, lobe and vane type blowers, gear pumps, textile machinery, wood-working machinery.	Machine tools, hot oil pumps, heavy-duty centrifugal pumps, cooling towers, slurry agitators, boiler feed pumps, hoists, conveyors.	Dredge pumps, dynamometer drives, light-duty hammermills, lineshafts, paper-converting machinery, rotary kilns, rotary or screw-type pumps for high viscosity fluids, paper mill cranes.	Mine ventilating fans, reciprocating pumps or compressors, paper making machinery, heavy-duty hammermills, ore crushers, pulverizing mills.
PRIME MOVER				
Steam, gas or air turbine	1.00	1.25	1.50	1.75
AC electric motor	1.25	1.50	1.50	1.75
DC electric motor or DOL start AC electric motor, hydraulic motors	1.25	1.50	1.75	2.00
Gasoline, natural gas, propane or other spark ignition engine	1.75	1.75	2.00	CONSULT ENGINEERING
Diesel*	2.00	2.50	2.75	CONSULT ENGINEERING

\* Consult application engineering on all engine drives.

Dual drive applications are to be treated as two single drives for service factor purposes.

For conveyor applications consult applications engineering.

For any application with extremes in inertia, starting torque, or questionable equipment, consult application engineering.

# NLS™ Centrifugal Clutches

## Easy Step by Step Selection Method

### Step #3

Specify the clutch selected.

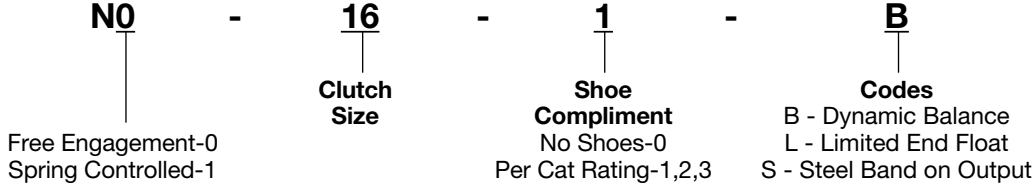

Sure-Grip bushings are sold separately.

Ordering examples:

- N016-2** 16A-2 clutch (no modifications)
- N016-2-B** 16A-2 clutch with dynamic balancing
- N016-2-S** 16A-2 clutch with steel ring
- N016-2-B-S** 16A-2 clutch with dynamic balancing and steel ring
- N016-B-L-S** 16A-2 clutch with dynamic balancing, limited end float, and steel ring
- J3316** J Sure-Grip bushing with a 3-3/16 bore

Note: All NLS clutches use non-asbestos shoe linings.

# NLS™ Centrifugal Clutches

## Easy Step by Step Selection Method

### Step #4

Calculate the Design HP (HP x service factor). Using the Design HP and the driving RPM, select the type and size clutch from the following charts.

### TYPE A

#### Free Engagement Horsepower Tables

In the NLS free engagement clutch the shoes are a free-moving part of the driving half to which the power is applied. As the driving half picks up speed the shoes are forced outward by centrifugal force into contact with the inside surface of the driven half (drum) which is attached to the load or driven machine. As the shoes make smooth contact, they slip momentarily, or until friction causes the driven half to rotate. When the driven equipment reaches full speed, complete engagement of the shoes with the driven half has taken place, and both members rotate as a unit with **no slippage, or power loss.**

Description	Bushing	Max. Bore	Product Number	Minimum Dynamic HP							Shoe Replacement			
				Minimum Driving RPM							Outer		Inner	
				400	500	600	720	870	1160	1750	Product No.	Qty.	Product No.	Qty.
4A-1	SH	1-5/8	N004-1	0.02	0.04	0.07	0.11	0.20	0.50	1.60	N004-408	2	NONE	
4A-2	SH		N004-2	0.04	0.07	0.13	0.23	0.40	0.90	3.30	N004-408	4	NONE	
4A-3	SH		N004-3	0.05	0.09	0.15	0.27	0.50	1.10	3.90	N004-412	4	NONE	
6A-1	SDS	1-15/16	N006-1	0.09	0.20	0.30	0.50	1.00	2.40	8.00	N006-613	2	NONE	
6A-2	SDS		N006-2	0.15	0.30	0.50	0.90	1.60	3.80	13.00	N006-613	3	NONE	
6A-3	SDS		N006-3	0.20	0.40	0.70	1.20	2.10	5.00	17.00	N006-613	4	NONE	
6A-4	SDS		N006-4	0.29	0.60	1.00	1.80	3.20	7.50	26.00	N006-613	6	NONE	
7A-1	SK	2-9/16	N007-1	0.38	0.75	1.30	2.20	3.90	9.40	32.00	N007-726	3	NONE	
7A-2	SK		N007-2	0.51	1.00	1.70	3.00	5.20	12.00	43.00	N007-726	4	NONE	
7A-3	SK		N007-3	0.77	1.50	2.60	4.50	7.90	19.00	64.00	N007-726	6	NONE	
8A-1	SF	2-15/16	N008-1	0.90	1.80	3.20	5.60	9.80	23.00	80.00	N008-834	4	NONE	
8A-2	SF		N008-2	1.00	2.00	3.60	6.00	11.00	26.00	88.00	N008-842	4	NONE	
8A-3	SF		N008-3	1.30	2.70	4.90	8.20	14.00	35.00	120.00	N008-834	6	NONE	
8A-4	SF		N008-4	1.50	3.00	5.40	9.10	16.00	38.00	132.00	N008-842	6	NONE	
10A-1	E	3-1/2	N010-1	1.50	3.00	5.50	9.00	16.00	38.00	132.00	N010-1033	4	N010-1026-I	4
10A-2	E		N010-2	1.50	3.50	6.00	10.00	18.00	43.00	149.00	N010-1042	4	N010-1026-I	4
10A-3	E		N010-3	2.00	4.50	7.50	13.00	24.00	56.00	192.00	N010-1033	6	N010-1026-I	6
10A-4	E		N010-4	2.50	5.00	9.00	15.00	28.00	65.00	224.00	N010-1042	6	N010-1026-I	6
12A-1	F	3-15/16	N012-1	3.00	6.50	12.00	19.00	35.00	82.00	285.00	N012-1275	3	N012-1256-I	3
12A-2	F		N012-2	4.00	8.50	16.00	26.00	47.00	110.00	380.00	N012-1275	4	N012-1256-I	3
12A-3	F		N012-3	6.00	12.00	21.00	36.00	65.00	154.00	533.00	N012-1260	6	N012-1256-I	6
12A-4	F		N012-4	6.50	13.00	23.00	39.00	70.00	165.00	570.00	N012-1275	6	N012-1256-I	6
14A-1	F	3-15/16	N014-1	8.50	17.00	31.00	51.00	92.00	217.00	749.00	N014-1453	6	N014-1468-I	3
14A-2	F		N014-2	10.00	20.00	36.00	60.00	108.00	255.00	879.00	N014-1470	6	N014-1468-I	4
14A-3	F		N014-3	13.00	27.00	48.00	81.00	144.00	340.00	1170.00	N014-1470	8	N014-1468-I	6
16A-1	J	4-1/2	N016-1	13.00	26.00	47.00	79.00	141.00	333.00	1150.00	N016-16110	4	N016-16100-I	3
16A-2	J		N016-2	14.00	28.00	50.00	84.00	150.00	354.00	1220.00	N016-1685	6	N016-16100-I	4
16A-3	J		N016-3	20.00	39.00	70.00	118.00	212.00	499.00	1720.00	N016-16110	6	N016-16100-I	4
16A-4	J		N016-4	26.00	53.00	93.00	158.00	282.00	666.00	2290.00	N016-16110	8	N016-16100-I	6
19A-1	BTS		N019-1	43.00	87.00	154.00	260.00	461.00	1090.00	...	N019-19150	6	N019-19100-I	6
19A-2	BTS		N019-2	57.00	115.00	204.00	346.00	614.00	1450.00	...	N019-19150	8	N019-19100-I	8
24A-1	BTS		N024-1	77.00	156.00	276.00	468.00	828.00	1967.00	...	N024-24140	8	N024-24180-I	4
24A-2	BTS		N024-2	114.00	221.00	391.00	663.00	1170.00	2785.00	...	N024-24200	8	N024-24180-I	6
24A-3	BTS		N024-3	164.00	332.00	587.00	995.00	1760.00	4180.00	...	N024-24200	12	N024-24180-I	8
24A-4	BTS		N024-4	219.00	443.00	783.00	1327.00	2345.00	5570.00	...	N024-24200	16	N024-24220-I	8
25A-1	BTS		N025-1	246.00	498.00	881.00	1490.00	2640.00	6270.00	...	N024-24200	18	N024-24180-I	8
25A-2	BTS		N025-2	287.00	581.00	1030.00	1740.00	3080.00	7310.00	...	N024-24200	21	N024-24220-I	8
25A-3	BTS		N025-3	342.00	669.00	1160.00	2000.00	3530.00	8360.00	...	N024-24200	24	N024-24180-I	8

Horsepower tables are based on ideal test conditions. As with all friction clutches, the actual horsepower will vary with application conditions. When using a model with inner shoes:

A) horsepower ratings prior to shoe lock-up (dynamic horsepower ratings) do not include inner shoe.

B) horsepower rating after complete shoe lock-up with inner shoe (static horsepower ratings) are approximately double the dynamic rating. For high speed applications and models above 10", consult application engineering.



### TYPE AD

#### Delayed Engagement Horsepower Tables

In the NLS delayed engagement clutch, shoe engagement is controlled by springs. The springs are fastened to the clutch shoes and inserted in slots in the driving half. Spring action holds the shoes out of engagement with the driven half until the driving half reaches a pre-determined RPM. Above this RPM, centrifugal force acting on the shoes overcomes the spring force allowing smooth engagement of the power source with the driven equipment. Since the shoes do not contact the driven half unless the driving half is started and accelerated, the delayed engagement type AD is ideal for dual or standby drives. The cushioned contact also means no sudden load imposed on motor, electrical, clutch or driven equipment.

Description	Bushing	Max. Bore	Product Number	Minimum Dynamic HP				Max. Idle RPM	Shoe Replacement	
				Minimum Driving RPM / Maximum Idle RPM					Outer	
				870/300*	1160/700*	1750/1000*	2500/1500*		Product No.	Qty.
4AD-1	SH	1-5/8	N104-1	0.18	0.31	1.10	3.20	300-1500	N104-9001	2
4AD-2	SH	1-5/8	N104-2	0.37	0.63	2.30	6.40	300-1500	N104-9001	4
6AD-1	SDS	1-15/16	N106-1	0.80	1.40	5.00	14.60	300-1500	N106-9001	2
6AD-2	SDS	1-15/16	N106-2	1.20	2.10	8.00	21.90	300-1500	N106-9001	3
6AD-3	SDS	1-15/16	N106-3	1.70	2.80	10.50	29.20	300-1500	N106-9001	4
6AD-4	SDS	1-15/16	N106-4	2.50	4.30	15.50	43.80	300-1500	N106-9001	6
7AD-1	SK	2-1/2	N107-1	3.00	5.00	18.50	50.00	300-1500	N107-9001	3
7AD-2	SK	2-1/2	N107-2	4.00	6.80	24.50	67.00	300-1500	N107-9001	4
7AD-3	SK	2-1/2	N107-3	6.00	10.90	37.00	100.00	300-1500	N107-9001	6
8AD-1	SF	2-15/16	N108-1	7.50	13.00	47.00	136.00	300-1500	N108-9001	4
8AD-2	SF	2-15/16	N108-2	11.50	19.50	71.00	204.00	300-1500	N108-9001	6
10AD-1	SF	2-15/16	N110-1	17.00	30.00	109.00	—	300-1000	N110-9001	4
10AD-2	SF	2-15/16	N110-2	26.00	45.00	164.00	—	300-1000	N110-9001	6
12AD-1	F	3-15/16	N112-1	27.00	47.00	173.00	—	300-1000	N112-9001	2
12AD-2	F	3-15/16	N112-2	41.00	71.00	259.00	—	300-1000	N112-9001	3
12AD-3	F	3-15/16	N112-3	55.00	95.00	346.00	—	300-1000	N112-9001	4
12AD-4	F	3-15/16	N112-4	83.00	142.00	519.00	—	300-1000	N112-9001	6
14AD-1	F	3-15/16	N114-1	73.00	125.00	—	—	200-700	N114-9001	4
14AD-2	F	3-15/16	N114-2	110.00	188.00	—	—	200-700	N114-9001	6
14AD-3	F	3-15/16	N114-3	147.00	251.00	—	—	200-700	N114-9001	8
16AD-1	J	4-1/2	N116-1	100.00	172.00	—	—	200-700	N116-9001	2
16AD-2	J	4-1/2	N116-2	201.00	344.00	—	—	200-700	N116-9001	4
16AD-3	J	4-1/2	N116-3	302.00	516.00	—	—	200-700	N116-9001	6
16AD-4	J	4-1/2	N116-4	402.00	689.00	—	—	200-700	N116-9001	8
19AD-1	BTS		N119-1	521.00	—	—	—	200-500	N119-9001	6
19AD-2	BTS		N119-2	695.00	—	—	—	200-500	N119-9001	8
24AD-1	BTS		N124-1	701.00	—	—	—	50-300	N124-9001	4
24AD-2	BTS		N124-2	1402.00	—	—	—	50-300	N124-9001	8
24AD-3	BTS		N124-3	2103.00	—	—	—	50-300	N124-9001	12
24AD-4	BTS		N124-4	2805.00	—	—	—	50-300	N124-9001	16

\* Horsepower ratings listed are based on idle speed as indicated.

For high speed applications, models above 10", or special idle speeds, consult application engineering.

Horsepower ratings listed are based on ideal test conditions. As with all friction clutches, the actual horsepower will vary with application conditions.

### Step #5

Check high speed applications for dynamic balancing and steel band requirements.

Clutch Size	RPM		
	Dynamic Balance Between	Steel Band On Required Output Member Above	Max RPM with Max Shoe Compliment
4	4700-11500	5700	11500
6	3200-7600	3900	7600
7	2700-6600	3300	6600
8	2400-5700	2900	5700
10	1900-4600	2300	4600
12	1225-3800	1900	3800
14	1400-3300	1600	3300
16	1200-2900	1400	2900
19	1000-1750	1200	1750
24	900-1600	1000	1600
25	500-1600	1000	1600

# NLS™ Centrifugal Clutches

## Easy Step by Step Selection Method

### Step #6

Check bore size and available space envelope.

### TYPE A

#### Free Engagement

Dimensions in Inches

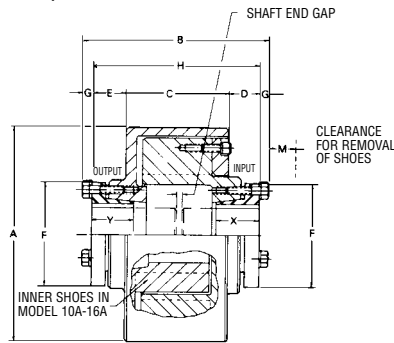

**MODELS 4A THRU 16A**

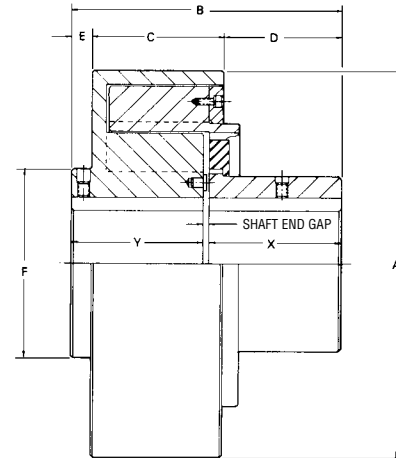

**MODELS 19A & 24A**

Clutch Size	Sure-Grip Bushing	Max. Keyed Bore	A	A with Steel Band	B	C	D	E	F	G	H	X	Y	Shaft End Gap		M	B+M	Approx. Wt. Lbs.
														Min	Max			
4A	SH	1-5/8	4.4375	—	4.8125	2.2500	1.1250	1.0000	2.7500	.2500	4.3750	1.0625	1.0625	.0625	2.0000	—	4.8125	8
6A	SDS	1-15/16	6.5000	7.4375	5.5313	3.0625	.9375	1.0313	3.1250	.2500	5.0313	1.3125	1.3125	.1250	2.4063	.8125	6.3438	25
7A	SK	2-1/2	7.6250	8.4375	7.3125	3.6250	1.5000	1.5625	3.8750	.3125	6.6875	1.9375	1.9375	.1250	2.8125	.6875	8.0000	40
8A	SF	2-15/16	8.7500	9.4375	8.0000	4.2500	1.2813	1.7813	4.6250	.3438	7.3125	2.2500	2.2500	.1250	2.8125	1.8750	9.8750	55
10A	E	3-1/2	10.7500	11.7500	10.5000	4.1250	3.1250	2.2500	6.0000	.5000	9.5000	3.0000	3.0000	.1250	3.5000	—	10.5000	105
12A	F	3-15/16	13.0000	14.0000	11.3750	5.5000	3.4375	1.3125	6.6250	.5625	10.2500	3.9375	3.9375	.1250	2.3750	—	11.3750	225
14A	F	3-15/16	15.0000	16.0000	11.3750	5.5000	3.4375	1.3125	6.6250	.5625	10.2500	3.9375	3.9375	.1250	2.3750	—	11.3750	250
16A	J	4-1/2	17.2500	18.2500	13.6250	6.6250	4.1875	1.5625	7.2500	.6250	12.3750	4.8750	4.8750	.1250	2.6250	—	13.6250	400
19A	BTS		20.5000	21.5000	14.8125	6.8750	6.2500	1.0625	10.0000	—	—	7.0000	7.0000	.1250	.1875	—	14.1875	600
24A	BTS		25.5000	26.5000	19.0625	9.8750	8.0000	1.0625	12.5000	—	—	8.7500	10.0000	.1250	.1875	—	19.0625	1225
25A	BTS		—	26.5000	24.1875	13.8750	9.2500	1.0625	12.5000	—	—	10.0000	10.0000	.1250	4.0781	—	24.1875	1400

### TYPE AD

#### Delayed Engagement

Dimensions in Inches

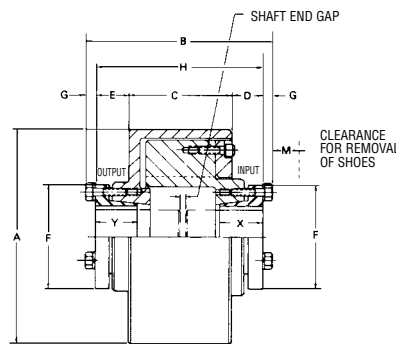

**MODELS 4AD THRU 16AD**

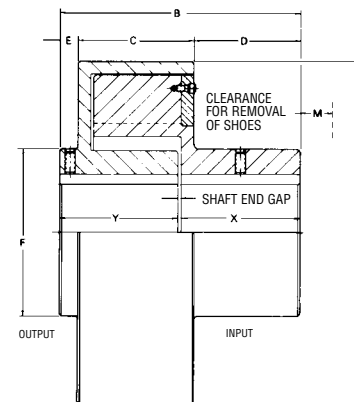

**MODELS 19AD & 24AD**

Clutch Size	Sure-Grip Bushing	Max. Keyed Bore	A	A with Steel Band	B	C	D	E	F	G	H	X	Y	Shaft End Gap		M	B+M	Approx. Wt. Lbs.
														Min	Max			
4AD	SH	1-5/8	4.4375	—	4.8125	2.2500	1.1250	1.0000	2.7500	.2500	4.3750	1.0625	1.0625	.0625	2.0000	—	4.8125	8
6AD	SDS	1-15/16	6.5000	7.4375	5.5313	3.0625	.9375	1.0313	3.1250	.2500	5.0313	1.3125	1.3125	.1250	2.0313	.8125	6.3438	25
7AD	SK	2-1/2	7.6250	8.4375	7.3125	3.6250	1.5000	1.5625	3.8750	.3125	6.6875	1.9375	1.9375	.1250	2.8125	.6875	8.0000	40
8AD	SF	2-15/16	8.7500	9.4375	8.0000	4.2500	1.2813	1.7813	4.6250	.3438	7.3125	2.2500	2.2500	.1250	2.8125	1.3750	9.3750	55
10AD	SF	2-15/16	10.7500	11.7500	8.5625	4.1250	2.0000	1.7500	5.1250	.3438	7.8750	2.2500	2.2500	.1250	3.5000	.6875	9.2500	105
12AD	F	3-15/16	13.0000	14.0000	11.3750	5.5000	3.4375	1.3125	6.6250	.5625	10.2500	3.9375	3.9375	.1250	2.3750	.6250	12.0000	215
14AD	F	3-15/16	15.0000	16.0000	11.3750	5.5000	2.1250	1.3125	6.6250	.5625	10.2500	3.9375	3.9375	.1250	2.3750	.6250	12.0000	240
16AD	J	4-1/2	17.2500	18.2500	13.6250	6.6250	4.1875	1.5625	7.2500	.6250	12.3750	4.8750	4.8750	.1250	2.6250	.6250	14.2500	385
19AD	BTS		20.5000	21.5000	14.1875	6.8750	6.2500	1.0625	10.0000	—	—	7.0000	7.0000	.1250	.1875	—	14.1875	575
24AD	BTS		25.5000	26.5000	18.9375	9.8750	8.0000	1.0625	12.5000	—	—	8.7500	8.7500	.1250	1.4375	—	18.9375	1175

### Bore and keyseat information

Sure Grip Bushing	Bores	Keyseat	Sure Grip Bushing	Bores	Keyseat	Standard Keyseat Dimensions		
						Shaft Dia.	Width	Depth
SH	1/2 - 1-3/8	Standard 3/8 x 1/16 No K.S.	E	7/8 - 2-7/8	Standard 3/4 X 1/8 7/8 X 1/16	1/2 - 9/16	1/8	1/16
	1-7/16 - 1-5/8			2-15/16 - 3-1/4		5/8 - 7/8	3/16	3/32
	1-11/16			3-5/16 - 3-1/2		15/16 - 1-1/4	1/4	1/8
SDS	1/2 - 1-11/16	Standard 3/8 x 1/8 1/2 x 1/8 1/2 x 1/16 No K.S.	F	1 - 3-1/4	Standard 7/8 X 3/16 1 X 1/8 NO K.S.	1-5/16 - 1-3/8	5/16	5/32
	1-3/4			3-5/16 - 3-3/4		1-7/16 - 1-3/4	3/8	3/16
	1-13/16			3-13/16 - 3-15/16		1-13/16 - 2-1/4	1/2	1/4
	1-7/8 - 1-15/16			4		2-5/16 - 2-3/4	5/8	5/16
SK	1/2 - 2-1/8	Standard 1/2 x 1/8 5/8 x 1/16 NO K.S.	J	1-7/16 - 3-13/16	Standard 1 X 3/8 1 X 1/8	2-13/16 - 3-1/4	3/4	3/8
	2-3/16 - 2-1/4			3-7/8 - 3-15/16		3-15/16 - 3-3/4	7/8	7/16
	2-5/16 - 2-1/2			4 - 4-1/2		3-13/16 - 4-1/2	1	1/2
	2-9/16 - 2-5/8			BTS NLS Models			4-9/16 - 5-1/2	1-1/4
SF	1/2 - 2-1/4	Standard 5/8 X 3/16 5/8 X 1/16 NO K.S.	Model      Bores      Keyseat			5-9/16 - 6-1/2	1-1/2	3/4
	2-5/16 - 2-1/2		19A & 19AD	3 - 5-5/8	Standard	6-9/16 - 7-1/2	1-3/4	3/4
	2-9/16 - 2-3/4		24A, 25A & 24AD	5-11/16 - 6-5/8	Shallow	7-9/16 - 9	2	3/4
	2-13/16 - 2-15/16			3-1/4 - 7	Standard			
			7-1/16 - 8-3/8	Shallow				

NOTE: When installing Sure-Grip bushings follow wrench torque supplied in NLS instructions.

### Step #7

Check clutch capacity for high inertia starts.

If inertia is not known or clutch speed is not listed, see step # 8.

Maximum WR <sup>2</sup> (lbs. ft. <sup>2</sup> ) that may be started at standard motor speeds.							
Clutch	870 RPM	1170 RPM	1750 RPM	Clutch	870 RPM	1170 RPM	1750 RPM
4	500	290	130	14	8000	4700	2100
6	1400	800	350	16	15000	8000	3700
7	2000	1100	510	19	22000	13000	5600
8	3000	1700	790	24	38000	20000	—
10	3800	2100	880	25	47600	26400	—
12	7000	4000	1800				

### Step #8

If inertia is not known or clutch speed is not listed on WR<sup>2</sup> chart.

#### ACCELERATION TABLE

Clutch Model No.	Energy Capacity Horsepower-Seconds
4A, 4AD	245
6A, 6AD	680
7A, 7AD	980
8A, 8AD	1,400
10A, 10AD	1,650
12A, 12AD	3,400
14A, 14AD	4,000
16A, 16AD	7,200
19A, 19AD	11,000
24A, 24AD	17,000
25A	25,000
30A	38,000

Maximum allowable acceleration time in seconds can be calculated by dividing the energy capacity in horsepower-seconds by the clutch design horsepower.

If actual acceleration time exceeds the maximum allowable time, a larger clutch should be selected or if the start-up frequency is more than 1 every half-hour.

**Example: A 12A-3 is rated at 533 hp @ 1750 with an energy capacity of 3400 Horsepower-seconds**

$$\frac{3400 \text{ Horsepower-seconds}}{533 \text{ Horsepower}} = 6.4 \text{ seconds maximum allowable acceleration time without a Steel Band}$$

By adding a Steel Band the acceleration time is increased by 35%  
 $6.4 \times 1.35 = 8.6 \text{ seconds with a Steel Band}$

# Sure-Grip Bushings

## Dimensions

Sure-Grip bushings are designed to transmit the rated torque capacity listed in the table below when the cap screws are tightened as indicated. The bushings are stocked in all popular bore sizes, including metric bores, within the bore range for a particular bushing.

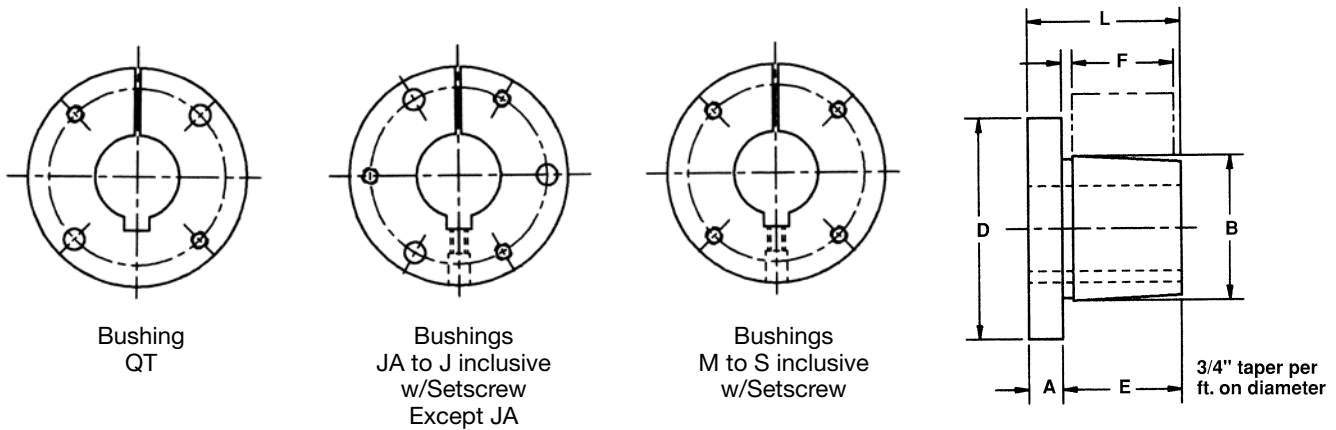

## SURE-GRIP BUSHING TORQUE RATINGS AND DIMENSIONS

Bush.	Torque Capacity (In.-Lbs.)	(Note 1) Max. Bore	(Note 2) Max. Bore	DIMENSIONS IN INCHES						Bolt Circle	Cap Screws Required	Recommended Cap Screw Torque (Ft.-Lbs.)
				A	B	D	E	F*	L			
SH	3,500	1.6250	36	.3750	1.8710	2.6875	.8750	.8125	1.2500	2.2500	3-1/4 x 1-3/8	6
SDS	5,000	1.9375	42	.4375	2.1875	3.1875	.8750	.7500	1.3125	2.6875	3-1/4 x 1-3/8	6
SD	5,000	1.9375	42	.4375	2.1875	3.1875	1.3750	1.2500	1.8125	2.6875	3-1/4 x 1-7/8	6
SK	7,000	2.5000	56	.5000	2.8125	3.8750	1.3750	1.2500	1.8750	3.3125	3-5/16 x 2	10
SF	11,000	2.9375	63	.5000	3.1250	4.6250	1.5000	1.2500	2.0000	3.8750	3-3/8 x 2	2
E	20,000	3.5000	78	.7500	3.8340	6.0000	1.8750	1.6250	2.6250	5.0000	3-1/2 x 2-3/4	40
F	40,000	3.9375	90	.8125	4.4375	6.6250	2.8125	2.5000	3.6250	5.6250	3-9/16 x 3-5/8	50
J	55,000	4.5000	105	1.000	5.1484	7.2500	3.5000	3.1875	4.5000	6.2500	3-5/8 x 4-1/2	75
M	125,000	5.5000	130	1.250	6.500	9.1250	5.5000	5.1875	6.7500	7.8750	4-3/4 x 6-3/4	100
N	150,000	6.0000	140	1.500	7.000	10.000	6.6250	6.2500	8.1250	8.5000	4-7/8 x 8	150

\* Mating hub length.

1. MAX INCH BORE WITH KEYSEAT.
2. MAX MM BORE WITH STANDARD KEYSEAT.

**SEE PAGES 91-93 FOR BORE AND KEYSEAT INFORMATION AND WEIGHTS.**



# Sure-Grip Bushings

## BORE AND KEYSEAT DIMENSIONS

(INCHES)

Product No.	Bore	Key Seat	Wt. (*)
<b>E BUSHINGS (continued)</b>			
E1	1	1/4 X 1/8	10.7
E118	1-1/8	1/4 X 1/8	10.6
E1316	1-3/16	1/4 X 1/8	10.5
E114	1-1/4	1/4 X 1/8	10.4
E1516	1-5/16	5/16 X 5/32	10.3
E138	1-3/8	5/16 X 5/32	10.2
E13838KS	1-3/8	3/8 X 3/16	10.2
E1716	1-7/16	3/8 X 3/16	10.1
E112	1-1/2	3/8 X 3/16	10.0
E1916	1-9/16	3/8 X 3/16	9.9
E158	1-5/8	3/8 X 3/16	9.8
E11116	1-11/16	3/8 X 3/16	9.7
E134	1-3/4	3/8 X 3/16	9.6
E11316	1-13/16	1/2 X 1/4	9.4
E178	1-7/8	1/2 X 1/4	9.3
E11516	1-15/16	1/2 X 1/4	9.2
E2	2	1/2 X 1/4	9.0
E2116	2-1/16	1/2 X 1/4	8.9
E218	2-1/8	1/2 X 1/4	8.8
E2316	2-3/16	1/2 X 1/4	8.6
E214	2-1/4	1/2 X 1/4	8.5
E21458KS	2-1/4	5/8 X 5/16	8.5
E2516	2-5/16	5/8 X 5/16	8.3
E238	2-3/8	5/8 X 5/16	8.1
E2716	2-7/16	5/8 X 5/16	8.0
E212	2-1/2	5/8 X 5/16	7.8
E2916	2-9/16	5/8 X 5/16	7.6
E258	2-5/8	5/8 X 5/16	7.5
E2116	2-11/16	5/8 X 5/16	7.3
E234	2-3/4	5/8 X 5/16	7.1
E21316	2-13/16	3/4 X 3/8	7.2
E278	2-7/8	3/4 X 3/8	7.1
E21516	2-15/16	3/4 X 1/8	6.9
E3	3	3/4 X 1/8	6.7
E318	3-1/8	3/4 X 1/8	6.3
E3316	3-3/16	3/4 X 1/8	6.0
E314	3-1/4	3/4 X 1/8	5.8
E3516	3-5/16	7/8 X 1/16	5.7
E338	3-3/8	7/8 X 1/16	5.5
E3716	3-7/16	7/8 X 1/16	5.2
E312	3-1/2	7/8 X 1/16	4.7
<b>F BUSHINGS</b>			
FMPB	1	No KS	17.9
F1	1	1/4 X 1/8	17.9
F118	1-1/8	1/4 X 1/8	17.7
F1316	1-3/16	1/4 X 1/8	17.6
F114	1-1/4	1/4 X 1/8	17.5
F138	1-3/8	5/16 X 5/32	17.2
F1716	1-7/16	3/8 X 3/16	17.1
F112	1-1/2	3/8 X 3/16	16.9
F1916	1-9/16	3/8 X 3/16	16.8

Product No.	Bore	Key Seat	Wt. (*)
<b>F BUSHINGS (continued)</b>			
F158	1-5/8	3/8 X 3/16	16.7
F134	1-3/4	3/8 X 3/16	16.3
F178	1-7/8	1/2 X 1/4	16.0
F11516	1-15/16	1/2 X 1/4	15.8
F2	2	1/2 X 1/4	15.6
F2116	2-1/16	1/2 X 1/4	15.4
F218	2-1/8	1/2 X 1/4	15.2
F2316	2-3/16	1/2 X 1/4	15.0
F214	2-1/4	1/2 X 1/4	14.8
F21458KS	2-1/4	5/8 X 5/16	14.8
F2516	2-5/16	5/8 X 5/16	14.5
F238	2-3/8	5/8 X 5/16	14.3
F2716	2-7/16	5/8 X 5/16	14.1
F212	2-1/2	5/8 X 5/16	13.9
F2916	2-9/16	5/8 X 5/16	13.7
F258	2-5/8	5/8 X 5/16	13.4
F21116	2-11/16	5/8 X 5/16	13.2
F234	2-3/4	5/8 X 5/16	12.9
F21316	2-13/16	3/4 X 3/8	12.6
F278	2-7/8	3/4 X 3/8	12.3
F21516	2-15/16	3/4 X 3/8	12.1
F3	3	3/4 X 3/8	11.8
F318	3-1/8	3/4 X 3/8	11.2
F3316	3-3/16	3/4 X 3/8	10.9
F314	3-1/4	3/4 X 3/8	10.6
F3516	3-5/16	7/8 X 3/16	11.0
F338	3-3/8	7/8 X 3/16	10.6
F3716	3-7/16	7/8 X 3/16	10.3
F312	3-1/2	7/8 X 3/16	10.0
F358	3-5/8	7/8 X 3/16	9.4
F31116	3-11/16	7/8 X 3/16	9.0
F334	3-3/4	7/8 X 3/16	8.7
F378	3-7/8	1 X 1/8	8.1
F31516	3-15/16	1 X 1/8	7.7
F4	4	No KS	6.9
<b>J BUSHINGS</b>			
JMPBR	1-7/16	No KS	28.1
J1716	1-7/16	3/8 X 3/16	28.1
J112	1-1/2	3/8 X 3/16	28.0
J1916	1-9/16	3/8 X 3/16	27.8
J11116	1-11/16	3/8 X 3/16	27.4
J134	1-3/4	3/8 X 3/16	27.2
J178	1-7/8	1/2 X 1/4	26.7
J11516	1-15/16	1/2 X 1/4	26.5
J2	2	1/2 X 1/4	26.3
J218	2-1/8	1/2 X 1/4	25.8
J2316	2-3/16	1/2 X 1/4	25.6
J214	2-1/4	1/2 X 1/4	25.3
J2516	2-5/16	5/8 X 5/16	25.0
J238	2-3/8	5/8 X 5/16	24.7

Product No.	Bore	Key Seat	Wt. (*)
<b>J BUSHINGS (continued)</b>			
J2716	2-7/16	5/8 X 5/16	24.5
J212	2-1/2	5/8 X 5/16	24.2
J258	2-5/8	5/8 X 5/16	23.6
J21116	2-11/16	5/8 X 5/16	23.3
J234	2-3/4	5/8 X 5/16	23.0
J278	2-7/8	3/4 X 3/8	22.2
J21516	2-15/16	3/4 X 3/8	21.9
J3	3	3/4 X 3/8	21.6
J318	3-1/8	3/4 X 3/8	20.9
J3316	3-3/16	3/4 X 3/8	20.5
J314	3-1/4	3/4 X 3/8	20.1
J3516	3-5/16	7/8 X 7/16	19.6
J338	3-3/8	7/8 X 7/16	19.3
J3716	3-7/16	7/8 X 7/16	18.9
J312	3-1/2	7/8 X 7/16	18.5
J358	3-5/8	7/8 X 7/16	17.7
J31116	3-11/16	7/8 X 7/16	17.2
J334	3-3/4	7/8 X 7/16	16.8
J31316	3-13/16	1 X 1/2	17.4
J378	3-7/8	1 X 3/8	17.0
J31516	3-15/16	1 X 3/8	16.5
J4	4	1 X 1/8	16.1
J418	4-1/8	1 X 1/8	15.2
J4316	4-3/16	1 X 1/8	14.7
J414	4-1/4	1 X 1/8	14.2
J438	4-3/8	1 X 1/8	13.2
J4716	4-7/16	1 X 1/8	12.7
J412	4-1/2	1 X 1/8	12.2

\* Approximate weight in lbs.

MPB Bushings are unsplit.

### BORE AND KEY INFORMATION

Product No.	Bore (mm)	Key □	Wt. (*)	Product No.	Bore (mm)	Key □	Wt. (*)	Product No.	Bore (mm)	Key □	Wt. (*)
<b>SH BUSHINGS</b>				<b>SF BUSHINGS</b>				<b>J BUSHINGS</b>			
SH24MM	24	8 X 7	.9	SF28MM	28	8 X 7	4.7	J50MM	50	14 X 9	26.5
SH25MM	25	8 X 7	.9	SF30MM	30	8 X 7	4.6	J55MM	55	16 X 10	25.6
SH28MM	28	8 X 7	.9	SF32MM	32	10 X 8	4.5	J60MM	60	18 X 11	24.7
SH30MM	30	8 X 7	.8	SF35MM	35	10 X 8	4.4	J65MM	65	18 X 11	23.9
SH32MM	32	10 X 8	.8	SF38MM	38	10 X 8	4.2	J70MM	70	20 X 12	23.0
SH35MM	35	10 X 8	.7	SF40MM	40	12 X 8	4.2	J75MM	75	20 X 12	21.9
<b>SDS BUSHINGS</b>				<b>E BUSHINGS</b>							
SDS24MM	24	8 X 7	1.5	SF42MM	42	12 X 8	4.1	E35MM	35	10 X 8	10.2
SDS25MM	25	8 X 7	1.5	SF45MM	45	14 X 9	3.9	E38MM	38	10 X 8	10.0
SDS28MM	28	8 X 7	1.4	SF48MM	48	14 X 9	3.7	E40MM	40	12 X 8	9.9
SDS30MM	30	8 X 7	1.4	SF50MM	50	14 X 9	3.6	E42MM	42	12 X 8	9.8
SDS32MM	32	10 X 8	1.3	SF55MM	55	16 X 10	3.2	E45MM	45	14 X 9	9.6
SDS35MM	35	10 X 8	1.2	SF60MM	60	18 X 11	3.0	E48MM	48	14 X 9	9.3
SDS38MM	38	10 X 8	1.1	SF65MM	65	18 X 8†	2.6	E50MM	50	14 X 9	9.2
SDS40MM	40	12 X 8	1.1					E55MM	55	16 X 10	8.6
SDS42MM	42	12 X 8	1.0					E60MM	60	18 X 11	8.1
<b>SD BUSHINGS</b>								E65MM	65	18 X 11	7.6
SD24MM	24	8 X 7	1.8					E70MM	70	20 X 12	7.1
SD25MM	25	8 X 7	1.8					E75MM	75	20 X 12	6.9
SD28MM	28	8 X 7	1.7					E80MM	80	22 X 11†	6.3
SD30MM	30	8 X 7	1.7								
SD32MM	32	10 X 8	1.6								
SD35MM	35	10 X 8	1.5								
SD38MM	38	10 X 8	1.4								
SD40MM	40	12 X 8	1.3								
SD42MM	42	12 X 8	1.2								
<b>SK BUSHINGS</b>				<b>F BUSHINGS</b>							
SK24MM	24	8 X 7	3.3	F45MM	45	14 X 9	16.2				
SK25MM	25	8 X 7	3.3	F48MM	48	14 X 9	16.0				
SK28MM	28	8 X 7	3.2	F50MM	50	14 X 9	15.8				
SK30MM	30	8 X 7	3.2	F55MM	55	16 X 10	15.0				
SK32MM	32	10 X 8	3.1	F60MM	60	18 X 11	14.3				
SK35MM	35	10 X 8	3.0	F65MM	65	18 X 11	13.7				
SK38MM	38	10 X 8	2.9	F70MM	70	20 X 12	12.9				
SK40MM	40	12 X 8	3.6	F75MM	75	20 X 12	12.1				
SK42MM	42	12 X 8	2.7	F80MM	80	22 X 14	11.2				
SK45MM	45	14 X 9	2.6	F85MM	85	22 X 14	10.6				
SK48MM	48	14 X 9	2.4	F90MM	90	25 X 14	9.7				
SK50MM	50	14 X 9	2.3								
SK55MM	55	16 X 10	2.0								

\* Approximate weight in lbs.

□ The metric system does not refer to keyseat or keyway dimensions as does the English system; instead, dimensions are given for the key itself, which is rectangular in shape and not square as in the English system. This meets ISO standards.

† SHALLOW KEY FURNISHED

# Centric Centrifugal Clutches

## Selection Guide

To select or order a Boston Gear Centric Centrifugal Clutch, please complete the following information and fax this form to Product Support at 800-816-5608.

### General Information

Company			
Address		City	State
Contact Person	Tel. No.	Fax No.	

### Application Data

1. Drive method: <input type="checkbox"/> Electric Motor <input type="checkbox"/> Engine/Turbine <input type="checkbox"/> Other
2. Method of drive: <input type="checkbox"/> Direct (Coupling Style) <input type="checkbox"/> Indirect Pulley Mounted (provide sketch)
3. Power transmission requirements at clutch location: Horsepower _____ Typical running RPM (If range required, specify range.) _____
4. Type: <input type="checkbox"/> Standard (A) <input type="checkbox"/> Vertical Lift-Out (V)
5. Speeds (required for engines, turbines, dual drives): Idling _____ RPM    Engagement _____ RPM
6. Bores: Driver (input) _____ inches    Driver (output) _____ inches
7. Service Factor Required: _____

Use the space below to sketch any relevant application data:

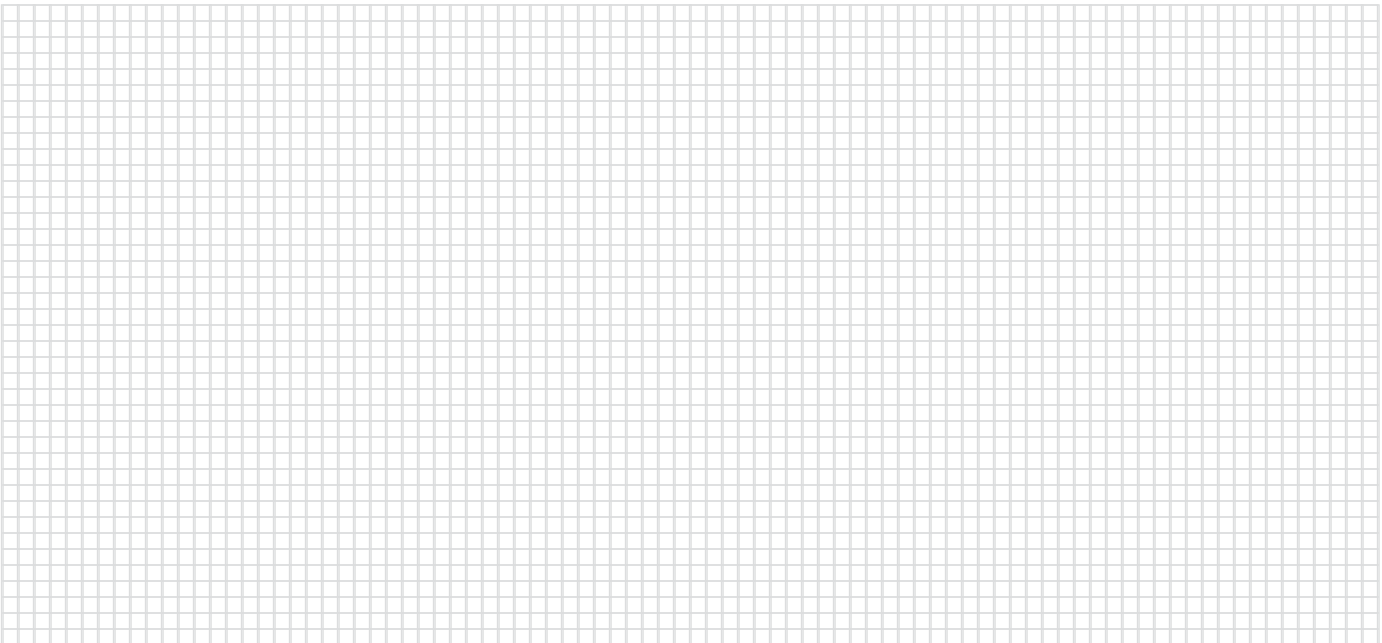





## Section Contents

BORE CODES .....	96
CLUTCH LOCATION .....	97
SERVICE FACTORS .....	98
APPLICATION FORMULAS.....	100
HORSEPOWER AND TORQUE.....	101
METRIC CONVERSION.....	103

# Engineering Information

## Bore Codes

Use the appropriate bore code shown below to designate the bore diameter (in inches) for the clutch's unit and coupling.

Bore Size (Fraction)	Bore Size (Decimal)	Bore Code
1/8	0.1250	P02
3/16	0.1875	P03
1/4	0.2500	P04
5/16	0.3125	P05
3/8	0.3750	P06
7/16	0.4375	P07
1/2	0.5000	P08
9/16	0.5625	P09
5/8	0.6250	P10
11/16	0.6875	P11
3/4	0.7500	P12
13/16	0.8125	P13
7/8	0.8750	P14
15/16	0.9375	P15
1	1.0000	P16
1-1/16	1.0625	P17
1-1/8	1.1250	P18
1-3/16	1.1875	P19
1-1/4	1.2500	P20
1-5/16	1.3125	P21
1-3/8	1.3750	P22
1-7/16	1.4375	P23
1-1/2	1.5000	P24
1-9/16	1.5625	P25
1-5/8	1.6250	P26
1-11/16	1.6875	P27
1-3/4	1.7500	P28
1-13/16	1.8125	P29
1-7/8	1.8750	P30
1-15/16	1.9375	P31
2	2.0000	P32
2-1/16	2.0625	P33
2-1/8	2.1250	P34
2-3/16	2.1875	P35
2-1/4	2.2500	P36
2-5/16	2.3125	P37
2-3/8	2.3750	P38
2-7/16	2.4375	P39
2-1/2	2.5000	P40
2-9/16	2.5625	P41
2-5/8	2.6250	P42
2-11/16	2.6875	P43
2-3/4	2.7500	P44
2-13/16	2.8125	P45
2-7/8	2.8750	P46
2-15/16	2.9375	P47
3	3.0000	P48
3-1/16	3.0625	P49
3-1/8	3.1250	P50
3-3/16	3.1875	P51
3-1/4	3.2500	P52
3-5/16	3.3125	P53
3-3/8	3.3750	P54
3-7/16	3.4375	P55
3-1/2	3.5000	P56

Bore Size (Fraction)	Bore Size (Decimal)	Bore Code
3-9/16	3.5625	P57
3-5/8	3.6250	P58
3-11/16	3.6875	P59
3-3/4	3.7500	P60
3-13/16	3.8125	P61
3-7/8	3.8750	P62
3-15/16	3.9375	P63
4	4.0000	P64
4-1/16	4.0625	P65
4-1/8	4.1250	P66
4-3/16	4.1875	P67
4-1/4	4.2500	P68
4-5/16	4.3125	P69
4-3/8	4.3750	P70
4-7/16	4.4375	P71
4-1/2	4.5000	P72
4-9/16	4.5625	P73
4-5/8	4.6250	P74
4-11/16	4.6875	P75
4-3/4	4.7500	P76
4-13/16	4.8125	P77
4-7/8	4.8750	P78
4-15/16	4.9375	P79
5	5.0000	P80
5-1/16	5.0625	P81
5-1/8	5.1250	P82
5-3/16	5.1875	P83
5-1/4	5.2500	P84
5-5/16	5.3125	P85
5-3/8	5.3750	P86
5-7/16	5.4375	P87
5-1/2	5.5000	P88
5-9/16	5.5625	P89
5-5/8	5.6250	P90
5-11/16	5.6875	P91
5-3/4	5.7500	P92
5-13/16	5.8125	P93
5-7/8	5.8750	P94
5-15/16	5.9375	P95
6	6.0000	P96
6-1/16	6.0625	P97
6-1/8	6.1250	P98
6-3/16	6.1875	P99
6-1/4	6.2500	P100
6-5/16	6.3125	P101
6-3/8	6.3750	P102
6-7/16	6.4375	P103
6-1/2	6.5000	P104
6-9/16	6.5625	P105
6-5/8	6.6250	P106
6-11/16	6.6875	P107
6-3/4	6.7500	P108
6-13/16	6.8125	P109
6-7/8	6.8750	P110
6-15/16	6.9375	P111
7	7.0000	P112

### Standard Keyways

Bore Range (Inch)	Square
Over - To	W x D
5/16 - 7/16	3/32 x 3/64
7/16 - 9/16	1/8 x 1/16
9/16 - 7/8	3/16 x 3/32
7/8 - 1-1/4	1/4 x 1/8
1-1/4 - 1-3/8	5/16 x 5/32
1-3/8 - 1-3/4	3/8 x 3/16
1-3/4 - 2-1/4	1/2 x 1/4
2-1/4 - 2-3/4	5/8 x 5/16
2-3/4 - 3-1/4	3/4 x 3/8
3-1/4 - 3-3/4	7/8 x 7/16
3-3/4 - 4-1/2	1 x 1/2
4-1/2 - 5-1/2	1-1/4 x 5/8
5-1/2 - 6-1/2	1-1/2 x 3/4
6-1/2 - 7-1/2	1-3/4 - 7/8

Square keyways will be furnished unless otherwise specified or noted in catalog.

Keys will be furnished with bores which require reduced keys.

### Bore Tolerances (Inch)

Diameter	Tolerance
0 to 1	+0.0005/-0.0000
1 to 3	+0.0010/-0.0000
3 and up	+0.0020/-0.0000

## Overload/Torque Limiting Clutch Location

### Location

The torque limiting clutch should always be located as close as possible to the potential source of an overload condition. Figures 1 through 4 indicate both preferred and non-preferred locations for mounting an Overload Release clutch.

#### Note:

Clutch mounted sprockets, etc. and couplings should be positioned as close to a supporting bearing as possible to minimize overhung loads. A minimum shaft engagement of 1-1/2 times the shaft diameter is recommended for clutch and coupling flange installation.

### Direct Drives

Figure 1 shows the preferred location for mounting in a direct drive application. The clutch is mounted on the low speed side of the reducer, and transmits power from its housing, through its rotor to the driven shaft.

Locating the clutch as shown in Figure 2 is **not preferred**. Here the clutch is mounted on the high-speed side of the reducer. Generally, mounting in this manner requires the clutch to be hypersensitive to perform satisfactorily.

### Indirect Drives

Either location of the clutch shown in Figure 3 is **preferred** in indirect drive applications, with the overload protection on the slow speed side of the reducer.

The mounting location in Figure 4 is **not preferred** for the same reasons as those for Figure 2. Always consult the factory when a mounting of this type is necessary.

Figure 1 Direct Drive Preferred

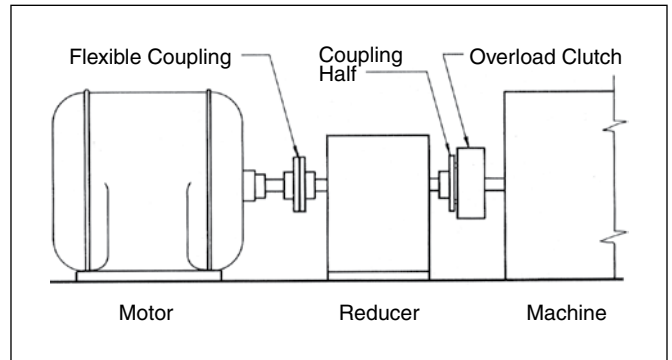

Figure 2 Direct Drive Not Preferred

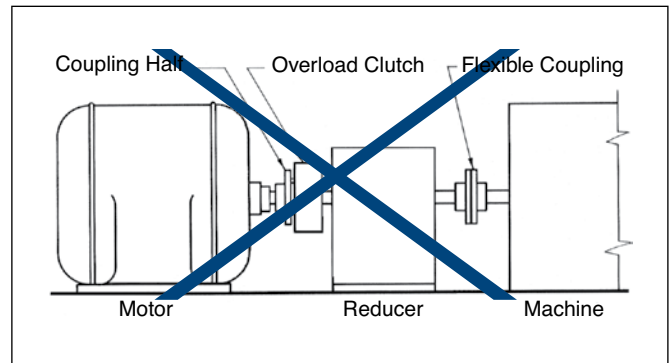

Figure 3 Indirect Drive Preferred

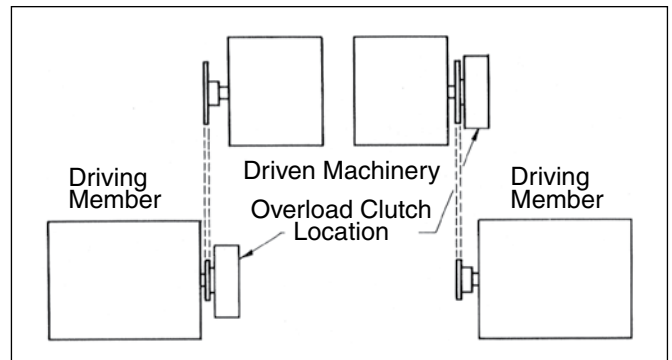
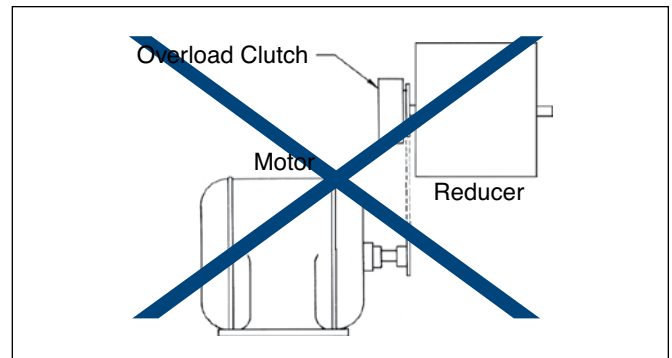

Figure 4 Indirect Drive Not Preferred



## Application Classification for Various Loads

Type of Machine To Be Driven	Chart I For All Drives		
	Service Factor Loading		
	Not More Than 15 Mins. in 2 Hrs.	Not More Than 10 Hrs. per Day	More Than 10 Hrs. Per Day
<b>AGITATORS</b>			
Pure Liquid	0.80	1.00	1.25
Semi-Liquids, Variable Density	1.00	1.25	1.50
<b>BLOWERS</b>			
Centrifugal and Vane	0.80	1.00	1.25
Lobe	1.00	1.25	1.50
<b>BREWING AND DISTILLING</b>			
Bottling Machinery	0.80	1.00	1.25
Brew Kettles—Continuous Duty	—	—	1.25
Cookers – Continuous Duty	—	—	1.25
Mash Tubs – Continuous Duty	—	—	1.25
Scale Hopper – Frequent Starts	—	1.25	1.50
<b>CAN FILLING MACHINES</b>	—	<b>1.00</b>	—
<b>CANE KNIVES</b>	—	1.50	—
<b>CAR DUMPERS</b>	—	1.75	—
<b>CAR PULLERS</b>	—	1.25	—
<b>CLARIFIERS</b>	—	1.00	1.25
<b>CLASSIFIERS</b>	—	1.25	1.50
<b>CLAY WORKING MACHINERY</b>			
Brick Press & Briquette Machine	—	1.75	2.00
Extruders and Mixers	1.00	1.25	1.50
<b>COMPRESSORS</b>			
Centrifugal	—	1.00	1.25
Lobe – Reciprocating, Multi-Cycle	—	1.25	1.50
Reciprocating – Single Cycle	—	1.75	2.00
<b>CONVEYORS—</b>			
<b>UNIFORMLY LOADED &amp; FED</b>			
Apron	—	1.00	1.25
Assembly-Belt – Bucket or Pan	—	1.00	1.25
Chain – Flight	—	1.00	1.25
Oven – Live Roll – Screw	—	1.00	1.25
<b>CONVEYORS—HEAVY DUTY</b>			
<b>NOT UNIFORMLY FED</b>			
Apron	—	1.25	1.50
Assembly-Belt – Bucket or Pan	—	1.25	1.50
Chain – Flight	—	1.25	1.50
Live Roll	—	—	—
Oven – Screw	—	1.25	1.50
Reciprocating – Shaker	—	1.75	2.00
<b>CRANES AND HOISTS</b>			
Main Hoists			
Bridge and Trolley Drive	*	1.00	1.25
<b>CRUSHERS</b>			
Ore, Stone	—	1.75	2.00
Sugar	—	1.50	1.50

Type of Machine To Be Driven	Chart I For All Drives		
	Service Factor Loading		
	Not More Than 15 Mins. in 2 Hrs.	Not More Than 10 Hrs. per Day	More Than 10 Hrs. Per Day
<b>ELEVATORS</b>			
Bucket – Uniform Load	—	1.00	1.25
Bucket – Heavy Load	—	1.25	1.50
Centrifugal Discharge	—	1.25	1.50
Freight	—	1.25	1.50
Gravity Discharge	—	1.00	1.25
<b>FANS</b>			
Centrifugal – Light (Small Diam.)	—	1.00	1.25
Large Industrial	—	1.25	1.50
<b>FEEDERS</b>			
Apron – Belt – Screw	—	1.25	1.50
Disc	—	1.00	1.25
Reciprocating	—	1.75	2.00
<b>FOOD INDUSTRY</b>			
Beet Slicer	—	1.25	1.50
Cereal Cooker	—	1.00	1.25
Dough Mixer – Meat Grinder	—	1.25	1.50
<b>GENERATORS (NOT WELDING)</b>	—	1.00	1.25
<b>HAMMER MILLS</b>	—	1.75	2.00
<b>HOISTS</b>			
Heavy Duty	—	1.75	2.00
Medium Duty and Skip Type	—	1.25	1.50
<b>LAUNDRY TUMBLERS</b>	—	1.25	1.50
<b>LINE SHAFTS</b>			
Uniform Load	—	1.00	1.25
Heavy Load	—	1.25	1.50
<b>MACHINE TOOLS</b>			
Auxiliary Drive	—	1.00	1.25
Main Drive – Uniform Load	—	1.25	1.50
Main Drive – Heavy Duty	—	1.75	2.00
<b>METAL MILLS</b>			
Draw Bench Carriers & Main Drive	—	1.25	1.50
<b>SLITTERS</b>	—	<b>1.25</b>	<b>1.50</b>
<b>TABLE CONVEYORS –</b>			
<b>NON REVERSING</b>			
Group Drives	—	1.25	1.50
Individual Drives	—	1.75	2.00
Wiring Drawing, Flattening or Winding	—	1.25	1.50
<b>MILLS ROTARY TYPE</b>			
<b>BALL AND ROD</b>			
Spur Ring Gear and Direct Connected	—	—	2.00
Cement Kilns, Pebble	—	—	1.50
Dryers and Coolers	—	—	1.50
Plain and Wedge Bar	—	—	1.50
Tumbling Barrels	—	—	2.00

## Application Classification for Various Loads (continued)

Type of Machine To Be Driven	Chart I For All Drives		
	Service Factor Loading		
	Not More Than 15 Mins. in 2 Hrs.	Not More Than 10 Hrs. per Day	More Than 10 Hrs. Per Day
<b>MIXERS</b>			
Concrete – Continuous	—	1.25	1.50
Concrete – Intermittent	—	1.25	1.50
Constant Density	—	1.00	1.25
Semi-Liquid	—	1.25	1.50
<b>OIL INDUSTRY</b>			
Oil Well Pumping	—	—	*
Chillers, Paraffin Filter Press	—	1.25	1.50
Rotary Kilns	—	1.25	1.50
<b>PAPER MILLS</b>			
Agitator (Mixer)	—	1.25	1.50
Agitator – Pure Liquids	—	1.00	1.25
Barking Drums – Mechanical			
Barkers	—	1.75	2.00
Bleacher	—	1.00	1.25
Beater	—	1.25	1.50
Calender Heavy Duty	—	—	2.00
Calender Anti-Friction Brgs.	—	1.00	1.25
Cylinders	—	1.25	1.50
Chipper	—	—	2.00
Chip Feeder	—	1.25	1.50
Coating Rolls – Couch Rolls	—	1.00	1.25
Conveyors – Chips – Bark – Chemical	—	1.00	1.25
Conveyors – Log and Slab	—	—	2.00
Cutter	—	—	2.00
Cylinder Molds, Dryers (Anti-Friction Brg.)	—	—	1.25
Felt Stretcher	—	1.25	1.50
Screens – Chip and Rotary	—	1.25	1.50
Thickener (AC)	—	1.25	1.50
Washer (AC)	—	1.25	1.50
Winder – Surface Type	—	—	1.25
<b>PLASTICS INDUSTRY</b>			
Intensive Internal Mixers			
Batch Type	—	—	1.75
Continuous Type	—	—	1.50
Batch Drop Mill – 2 Rolls	—	—	1.25
Compounding Mills	—	—	1.25
Calenders	—	—	1.50
Extruder – Variable Speed	—	—	1.50
Extruder – Fixed Speed	—	—	1.75
<b>PULLERS</b>			
Barge Haul	—	—	2.00

Type of Machine To Be Driven	Chart I For All Drives		
	Service Factor Loading		
	Not More Than 15 Mins. in 2 Hrs.	Not More Than 10 Hrs. per Day	More Than 10 Hrs. Per Day
<b>PUMPS</b>			
Centrifugal	—	—	1.25
Proportioning	—	—	1.50
Reciprocating			
Single Acting, 3 or more Cycles	—	1.25	1.50
Double Acting, 2 or more Cycles	—	1.25	1.50
Rotary – Gear or Lube	—	1.00	1.25
<b>RUBBER INDUSTRY</b>			
Batch Mixers	—	—	1.75
Continuous Mixers	—	—	1.50
Calenders	—	—	1.50
Extruders – Continuous	—	—	1.50
Extruders – Intermittent	—	—	1.75
Tire Building Machines	—	—	—
Tire & Tube Press Openers	—	—	—
<b>SEWAGE DISPOSAL EQUIPMENT</b>			
Bar Screens	—	1.00	1.25
Chemical Feeders	—	1.00	1.25
Collectors	—	1.00	1.25
Dewatering Screws	—	1.25	1.50
Scum Breakers	—	1.25	1.50
Slow or Rapid Mixers	—	1.25	1.50
Thickeners	—	1.25	1.50
Vacuum Filters	—	1.25	1.50
<b>SCREENS</b>			
Air Washing	—	1.00	1.25
Rotary – Stone or Gravel	—	1.25	1.50
Traveling Water Intake	—	1.00	1.25
<b>SKIP HOISTS</b>	—	—	—
<b>SLAB PUSHERS</b>	—	1.25	1.50
<b>STOKERS</b>	—	—	1.25
<b>TEXTILE INDUSTRY</b>			
Batchers or Calenders	—	1.25	1.50
Cards	—	1.25	1.50
Card Machines	—	1.75	2.00
Dry Cans and Dryers	—	1.25	1.50
Dyeing Machines	—	1.25	1.50
Looms	—	1.25	1.50
Mangles, Nappers and Pads	—	1.25	1.50
Soapers, Tenner Frames	—	1.25	1.50
Spinners, Washers, Winders	—	1.25	1.50
<b>TUMBLING BARRELS</b>	1.50	1.75	2.00
<b>WINDLASS</b>	—	1.25	1.50

This list is not all-inclusive and each application should be checked to determine if any unusual operating conditions will be encountered.

# Engineering Information

## Application Formulas

TO OBTAIN	HAVING	FORMULA
Velocity (V) Feet Per Minute	Pitch Diameter (D) of Gear or Sprocket - Inches and Revolutions Per Minute (RPM)	$V = .2618 \times D \times \text{RPM}$
Revolutions Per Minute (RPM)	Velocity (V) Feet Per Minute and Pitch Diameter (D) of Gear or Sprocket - Inches	$\text{RPM} = \frac{V}{.2618 \times D}$
Pitch Diameter (D) of Gear or Sprocket	Velocity (V) Feet Per Minute and Revolutions Per Minute (RPM)	$D = \frac{V}{.2618 \times \text{RPM}}$
Torque (T) In. Lbs.	Force (W) Lbs. and Radius (R) Inches	$T = W \times R$
Horsepower (HP)	Force (W) Lbs. and Velocity (V) Feet Per Minute	$\text{HP} = \frac{W \times V}{33000}$
Horsepower (HP)	Torque (T) In. Lbs. and Revolutions Per Minute (RPM)	$\text{HP} = \frac{T \times \text{RPM}}{63025}$
Torque (T)	Horsepower (HP) and Revolutions Per Minute (RPM)	$T = \frac{63025 \times \text{HP}}{\text{RPM}}$
Force (W) Lbs.	Horsepower (HP) and Velocity (V) Feet Per Minute	$W = \frac{33000 \times \text{HP}}{V}$
Revolutions Per Minute (RPM)	Horsepower (HP) and Torque (T) In. Lbs.	$\text{RPM} = \frac{63025 \times \text{HP}}{T}$

**POWER** is the rate of doing work.

**WORK** is the exerting of a **FORCE** through a **DISTANCE**. **ONE FOOT POUND** is a unit of **WORK**. It is the **WORK** done in exerting a **FORCE OF ONE POUND** through a **DISTANCE OF ONE FOOT**.

**THE AMOUNT OF WORK** done (Foot Pounds) is the **FORCE** (Pounds) exerted multiplied by the **DISTANCE** (Feet) through which the **FORCE** acts.

**THE AMOUNT OF POWER** used (Foot Pounds per Minute) is the **WORK** (Foot Pounds) done divided by the **TIME** (Minutes) required.

$$\text{POWER (Foot Pounds per Minute)} = \frac{\text{WORK (Ft. Lbs.)}}{\text{TIME (Minutes)}}$$

**POWER** is usually expressed in terms of **HORSEPOWER**.

**HORSEPOWER** is **POWER** (Foot Pounds per Minute) divided by 33,000.

$$\begin{aligned} \text{HORSEPOWER (HP)} &= \frac{\text{POWER (Ft. Lbs. per Minute)}}{33,000} \\ &= \frac{\text{WORK (Ft. Pounds)}}{33,000 \times \text{TIME (Min.)}} \\ &= \frac{\text{FORCE (Lbs.)} \times \text{DISTANCE (Feet)}}{33,000 \times \text{TIME (Min.)}} \end{aligned}$$

### ILLUSTRATION OF HORSEPOWER

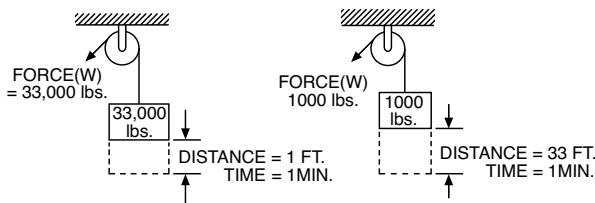

$$\text{HP} = \frac{33,000 \times 1}{33,000 \times 1} = 1 \text{ HP}$$

$$\text{HP} = \frac{1000 \times 33}{33,000 \times 1} = 1 \text{ HP}$$

**TORQUE (T)** is the product of a **FORCE (W)** in pounds, times a **RADIUS (R)** in inches from the center of shaft (Lever Arm) and is expressed in **Inch Pounds**.

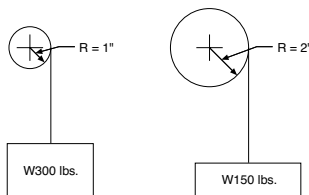

$$\begin{aligned} T &= WR \\ &= 300 \times 1 = 300 \text{ In. Lbs.} \end{aligned}$$

$$\begin{aligned} T &= WR \\ &= 150 \times 2 = 300 \text{ In. Lbs.} \end{aligned}$$

If the shaft is revolved, the **FORCE (W)** is moved through a distance, and **WORK** is done.

$$\text{WORK (Ft. Lbs.)} = W \times \frac{2\pi R}{12} \times \text{No. of Rev. of shaft}$$

When **WORK** is done in a specified **TIME**, **POWER** is used.

$$\text{POWER (Ft. Pounds per Minute)} = W \times \frac{2\pi R}{12} \times \text{RPM}$$

Since (1) **HORSEPOWER** = 33,000 Ft. Pounds per Minute

$$\text{Horsepower (HP)} = W \times \frac{2\pi R}{12} \times \frac{\text{RPM}}{33,000} = \frac{W \times R \times \text{RPM}}{63,025}$$

but **TORQUE** (Inch Pounds) = **FORCE (W)** x **RADIUS (R)**

$$\text{Therefore HORSEPOWER (HP)} = \frac{\text{TORQUE (T)} \times \text{RPM}}{63,025}$$

Where total reductions are small, 50 to 1 or less, **HP** figures are commonly used. Higher reductions require that **TORQUE** figures be used to select drive components, because with large reductions, a small motor can produce extremely high **TORQUE** at the final low speed. For example, 1/12 HP reduced to 1 RPM using the formula below and neglecting friction:

$$\text{HP} = \frac{\text{TORQUE} \times \text{RPM}}{63,025} \quad \text{or} \quad \text{TORQUE} = \frac{63,025 \times \text{HP}}{\text{RPM}}$$

$$\text{TORQUE} = \frac{63,025 \times 1/12}{1} = 5,252 \text{ In. Lbs.}$$

Therefore, motors for use with large reductions should be carefully selected. Even a small motor, if stalled, can produce enough **Torque** to ruin the drive, unless it is protected by an overload clutch.

Neglecting frictional losses, this sketch illustrates the manner in which **Torque** increases as speed decreases.

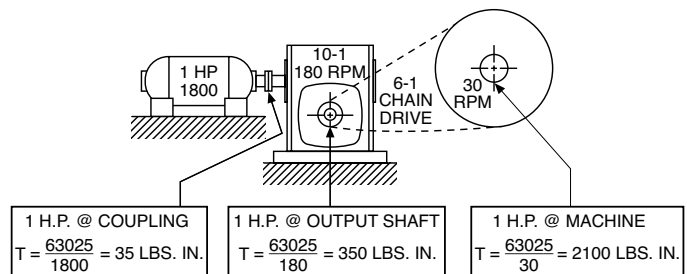

# Engineering Information

## Horsepower and Torque (continued)

### INERTIA (WK<sup>2</sup>)

The factor WK<sup>2</sup> is the weight (lbs) of an object multiplied by the square of the radius of gyration (K). The unit measurement of the radius of gyration is expressed in feet.

For solid or hollow cylinders, inertia may be calculated by the equations shown below.

The inertia of solid steel shafting per inch of shaft length is given in the table. To calculate for hollow shafts, take the difference between the inertia values for the O.D. and I.D. as the value per inch. For shafts of materials other than steel, multiply the value for steel by the appropriate material factor.

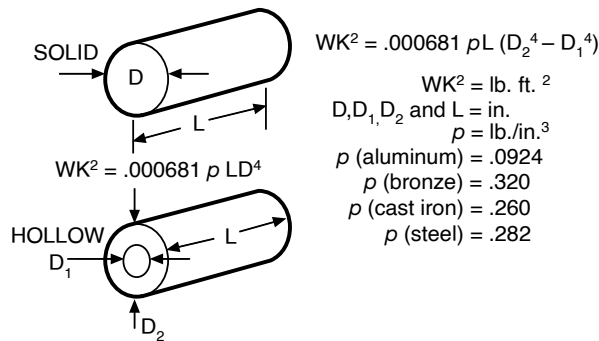

WK<sup>2</sup> of Rotating Elements – In practical mechanical systems, all the rotating parts do not operate at the same speed. The WK<sup>2</sup> of all moving parts operating at each speed must be reduced to an equivalent WK<sup>2</sup> at the motor shaft, so that they can all be added together and treated as a unit, as follows:

$$\text{Equivalent } WK^2 = WK^2 \left[ \frac{N}{N_M} \right]^2$$

Where,  
 WK<sup>2</sup> = Inertia of the moving part  
 N = Speed of the moving part (RPM)  
 N<sub>M</sub> = Speed of the driving motor (RPM)

When using speed reducers, and the machine inertia is reflected back to the motor shaft, the equivalent inertia is equal to the machine inertia divided by the square of the drive reduction ratio.

$$\text{Equivalent } WK^2 = \frac{WK^2}{(DR)^2}$$

Where, DR = drive reduction ratio =  $\frac{N_M}{N}$

### Inertia of Steel Shafting (Per Inch of Length)

Diam. (In.)	WK <sup>2</sup> (Lb. Ft. <sup>2</sup> )	Diam. (In.)	WK <sup>2</sup> (Lb. Ft. <sup>2</sup> )
3/4	0.00006	10-1/2	2.35
10.0002	10-3/4	2.58	
1-1/4	0.0005	11	2.83
1-1/2	0.001	11-1/4	3.09
1-3/4	0.002	11-1/2	3.38
20.003	11-3/4	3.68	
2-1/4	0.005	12	4.00
2-1/2	0.008	12-1/4	4.35
2-3/4	0.011	12-1/2	4.72
30.016	12-3/4	5.11	
3-1/2	0.029	13	5.58
3-3/4	0.038	13-1/4	5.96
40.049	13-1/2	6.42	
4-1/4	0.063	13-3/4	6.91
4-1/2	0.079	14	7.42
50.120	14-1/4	7.97	
5-1/2	0.177	14-1/2	8.54
60.250	14-3/4	9.15	
6-1/4	0.296	15	9.75
6-1/2	0.345	16	12.59
6-3/4	0.402	17	16.04
70.464	18	20.16	
7-1/4	0.535	19	25.03
7-1/2	0.611	20	30.72
7-3/4	0.699	21	37.35
80.791	22	44.99	
8-1/4	0.895	23	53.74
8-1/2	1.000	24	63.71
8-3/4	1.130	25	75.02
91.270	26	87.76	
9-1/4	1.410	27	102.06
9-1/2	1.550	28	118.04
9-3/4	1.750	29	135.83
10	1.930	30	155.55
10-1/4	2.130	—	—

### Material Factors

Shaft Material	Factor
Rubber	.121
Nylon	.181
Aluminum	.348
Bronze	1.135
Cast Iron	.922

### Formulas to Approximate WK<sup>2</sup>

For a solid cylinder or disc =  $W \times \frac{r^2}{2}$   
 where r = radius in feet and W is weight in pounds.

For a hollow cylinder:  $WK^2 \times \frac{r_1^2 + r_2^2}{2}$

where r<sub>1</sub> is  $\frac{ID}{2}$  and r<sub>2</sub> is  $\frac{OD}{2}$ .



MULTIPLY	BY	TO OBTAIN	MULTIPLY	BY	TO OBTAIN
<b>LENGTH</b>			<b>TORQUE</b>		
Millimeter	.03937	Inch	Newton-meter	8.84	Lb. In.
Centimeter	.3937	Inch	Lb. In.	.113	Newton-Meter
Meter	39.37	Inch	Lb. Ft.	1.3558	Newton-Meter
Inch	2.54	Centimeter	Lb. Ft.	12	Lb. In.
Feet	30.48	Centimeter	<b>MOMENT OF INERTIA</b>		
Feet	.3048	Meter	Newton-Meters <sup>2</sup>	2.42	Lb. Ft. <sup>2</sup>
<b>WEIGHT</b>			Oz.-In. <sup>2</sup>	.000434	Lb. Ft. <sup>2</sup>
Gram	.03527	Ounce	Lb.-In. <sup>2</sup>	.00694	Lb. Ft. <sup>2</sup>
Kilogram	35.27	Ounce	Slug-Ft. <sup>2</sup>	32.17	Lb. Ft. <sup>2</sup>
Kilogram	2.205	Pounds	Oz.-In.-Sec. <sup>2</sup>	.1675	Lb. Ft. <sup>2</sup>
Ounce	28.35	Grams	Lb.-In.-Sec. <sup>2</sup>	2.68	Lb. Ft. <sup>2</sup>
Pound	453.6	Grams	<b>POWER</b>		
<b>ROTATION</b>			Joule/sec	.001341	Horsepower
RPM	.1047	Rad./Sec.	Kilocalorie/hour	3.967	BTW/Hour
RPM	6.00	Degrees/Sec.	Horsepower	.33000	Lb. Ft./Min.
Degrees/Sec.	.1667	RPM	Horsepower	746	Watts
Rad./Sec	9.549	RPM	BTU/hour	.2521	Kilocalorie/Hour
<b>VELOCITY</b>			Watts	.00134	Horsepower
Centimeter/second	.3937	Inches/Second	<b>AREA</b>		
Centimeter/second	1.969	Feet/Minute	Millimeters <sup>2</sup>	.00155	Inches <sup>2</sup>
Meter/second	3.281	Feet/Second	Centimeters <sup>2</sup>	.155	Inches <sup>2</sup>
Meter/second	196.9	Feet/Minute	Meters <sup>2</sup>	10.76	Feet <sup>2</sup>
Meter/second	2.237	Miles per hour	Inches <sup>2</sup>	645.16	Millimeters <sup>2</sup>
Inch/second	25.4	Millimeters/Second	Inches <sup>2</sup>	6.452	Centimeters <sup>2</sup>
Inch/second	2.54	Centimeters/Second	Feet <sup>2</sup>	929.03	Centimeters <sup>2</sup>
Foot/second	.3048	Meters/Second	Feet <sup>2</sup>	.0929	Meters <sup>2</sup>
Foot/minute	.00508	Meters/Second	<b>DENSITY</b>		
<b>VOLUME</b>			lg/cm <sup>3</sup>	.03613	Lb/In <sup>3</sup>
Centimeter <sup>3</sup>	.0610	Inches <sup>3</sup>	lg/cm <sup>3</sup>	62.43	Lb/Ft <sup>3</sup>
Centimeter <sup>3</sup>	.034	Fluid Ounce	lb/in <sup>3</sup>	27.68	Gr/Cm <sup>3</sup>
Liter	61.02	Inches <sup>3</sup>	lb/ft <sup>3</sup>	.016	G/Cm <sup>3</sup>
Liter	.0353	Feet <sup>3</sup>	lb/ft <sup>3</sup>	16.02	Kg/M <sup>3</sup>
Liter	.264	U.S. Gallon			
Inch <sup>3</sup>	16.39	Centimeter <sup>3</sup>			
Feet <sup>3</sup>	28.32	Liter			
Gallon	3.785	Liter			



# Boston Gear Online Resources

VISIT US ON THE WEB AT  
[WWW.BOSTONGEAR.COM](http://WWW.BOSTONGEAR.COM)

## Everything Boston Gear

From the Boston Gear homepage you can explore all of our resources and visit our key market portals to find solutions for your specific needs.

[WWW.BOSTONGEAR.COM](http://WWW.BOSTONGEAR.COM)

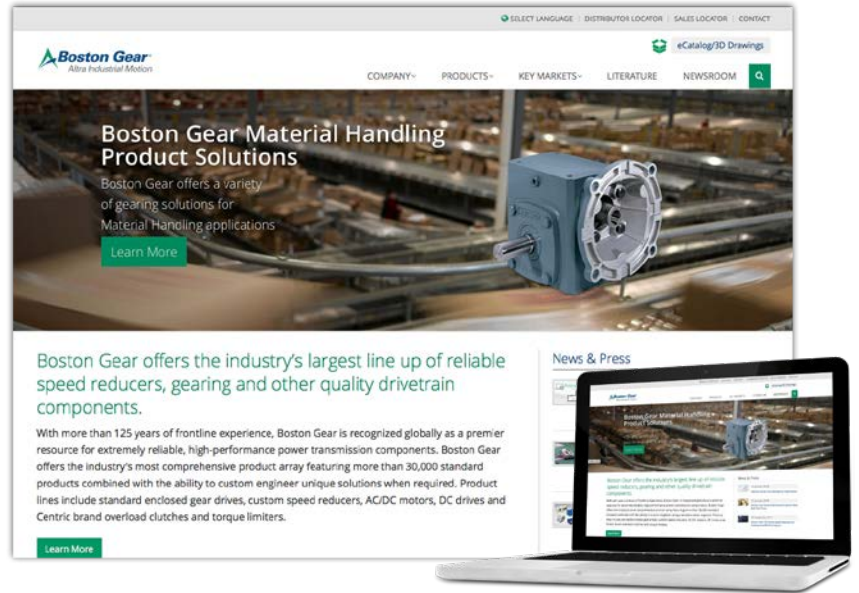

## Get Connected

The Boston Gear Newsroom makes it quick and easy for you to get the news you need when you need it. From new literature releases to trade show schedules, the news is at your fingertips 24 hours a day.

[WWW.BOSTONGEAR.COM/NEWSROOM](http://WWW.BOSTONGEAR.COM/NEWSROOM)

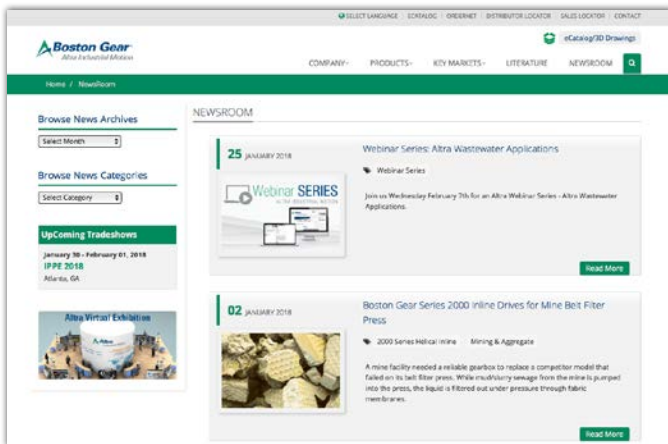

## Boston Gear eCatalog

The eCatalog offers product selections and comparisons to meet your specific needs. Download 2D and 3D CAD formats and dimensional line drawings.

Submit an online RFQ to the local distributor of your choice.

[WWW.BOSTONGEAR.COM/ECATALOG](http://WWW.BOSTONGEAR.COM/ECATALOG)

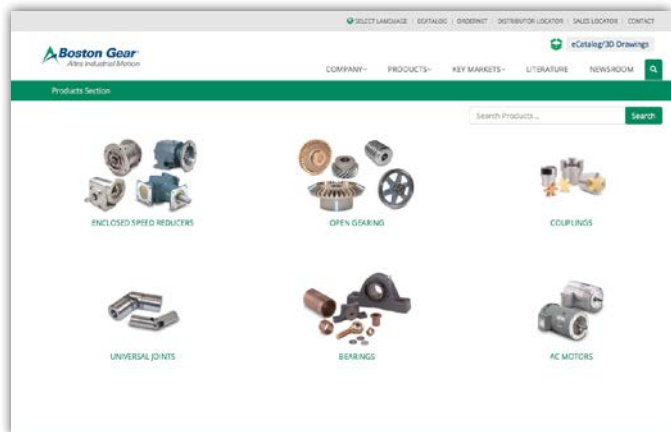

## Boston Gear Facilities

### North America

#### USA

701 Carrier Drive  
Charlotte, NC 28216 - USA  
704-588-5610

*Enclosed and Open Gearing,  
Electrical and Mechanical  
P.T. Components*

**Customer Service**  
1-888-999-9860

**Application Support**  
1-800-816-5608

## The Brands of Altra Motion

### Couplings

**Ameridrives**  
[www.ameridrives.com](http://www.ameridrives.com)

**Bibby Turboflex**  
[www.bibbyturboflex.com](http://www.bibbyturboflex.com)

**Guardian Couplings**  
[www.guardiancouplings.com](http://www.guardiancouplings.com)

**Huco**  
[www.huco.com](http://www.huco.com)

**Lamiflex Couplings**  
[www.lamiflexcouplings.com](http://www.lamiflexcouplings.com)

**Stromag**  
[www.stromag.com](http://www.stromag.com)

**TB Wood's**  
[www.tbwoods.com](http://www.tbwoods.com)

### Linear Systems

**Thomson**  
[www.thomsonlinear.com](http://www.thomsonlinear.com)

### Geared Cam Limit Switches

**Stromag**  
[www.stromag.com](http://www.stromag.com)

### Engineered Bearing Assemblies

**Kilian**  
[www.kilianbearings.com](http://www.kilianbearings.com)

### Electric Clutches & Brakes

**Matrix**  
[www.matrix-international.com](http://www.matrix-international.com)

**Stromag**  
[www.stromag.com](http://www.stromag.com)

**Warner Electric**  
[www.warnerelectric.com](http://www.warnerelectric.com)

### Belted Drives

**TB Wood's**  
[www.tbwoods.com](http://www.tbwoods.com)

### Heavy Duty Clutches & Brakes

**Twiflex**  
[www.twiflex.com](http://www.twiflex.com)

**Stromag**  
[www.stromag.com](http://www.stromag.com)

**Svendborg Brakes**  
[www.svendborg-brakes.com](http://www.svendborg-brakes.com)

**Wichita Clutch**  
[www.wichitaclutch.com](http://www.wichitaclutch.com)

### Gearing & Specialty Components

**Bauer Gear Motor**  
[www.bauergears.com](http://www.bauergears.com)

**Boston Gear**  
[www.bostongear.com](http://www.bostongear.com)

**Delevan**  
[www.delevan.com](http://www.delevan.com)

**Delroyd Worm Gear**  
[www.delroyd.com](http://www.delroyd.com)

**Nuttall Gear**  
[www.nuttallgear.com](http://www.nuttallgear.com)

### Engine Braking Systems

**Jacobs Vehicle Systems**  
[www.jacobsvehiclesystems.com](http://www.jacobsvehiclesystems.com)

### Precision Motors & Automation

**Kollmorgen**  
[www.kollmorgen.com](http://www.kollmorgen.com)

### Miniature Motors

**Portescap**  
[www.portescap.com](http://www.portescap.com)

### Overrunning Clutches

**Formsprag Clutch**  
[www.formsprag.com](http://www.formsprag.com)

**Marland Clutch**  
[www.marland.com](http://www.marland.com)

**Stieber**  
[www.stieberclutch.com](http://www.stieberclutch.com)

Neither the accuracy nor completeness of the information contained in this publication is guaranteed by the company and may be subject to change in its sole discretion. The operating and performance characteristics of these products may vary depending on the application, installation, operating conditions and environmental factors. The company's terms and conditions of sale can be viewed at <http://www.altramotion.com/terms-and-conditions/sales-terms-and-conditions>. These terms and conditions apply to any person who may buy, acquire or use a product referred to herein, including any person who buys from a licensed distributor of these branded products.

©2021 by Boston Gear LLC. All rights reserved. All trademarks in this publication are the sole and exclusive property of Boston Gear LLC or one of its affiliated companies.